

Operating and mounting manual

Safety shut off valve

solenoid valve

EVS

Contents

- 1.0 General Remarks**
 - 1.1 Valve data
 - 1.2 Application
- 2.0 Danger Notices**
 - 2.1 Safety terms
 - 2.2 Safety notice
 - 2.3 Qualified staff
 - 2.4 Unauthorized modification and spare part production
 - 2.5 Unauthorized operation
 - 2.6 Safety information for the use in explosion-prone areas guideline 2014/34/EU
 - 2.7 Safety information regarding guideline 2014/68/EU attachment I
- 3.0 Handling**
 - 3.1 Transport
 - 3.2 Storage
 - 3.3 Handling before mounting
- 4.0 Product Description**
 - 4.1 Function
 - 4.2 Technical data
 - 4.3 Marking
- 5.0 Installation**
 - 5.1 Warning of dangers during installation, operation and maintenance
 - 5.2 Installation
 - 5.2.1 Generally applicable installation guidelines
 - 5.2.2 Installation guidelines for installing valve housings with welding ends
- 6.0 Operation**
 - 6.1 Commissioning
 - 6.2 Shutting down
 - 6.3 Maintenance
 - 6.4 Putting back into operating
- 7.0 Troubleshooting**
 - 7.1 Detection of defects
 - 7.2 Troubleshooting plan
- 8.0 Dismantling of the Valve**
 - 8.1 Replacement of wear parts
- 9.0 Warranty**
- 10.0 Explanations on Codes and Directives**
- 11.0 Drawing**
 - 11.1 Sectional drawing
 - 11.2 List of parts
- 12.0 Declaration of Conformity**

1.0 General Remarks

This operating manual includes instructions to assemble and operate the valve in the prescribed and safe way. **Additionally, the adequate operating instructions of each special solenoid drive must be considered.**

Series MG...	220.100.038
Series MG...X	220.100.040
Series MG...Xme	220.100.039

If any difficulties appear that can not be solved by means of the operating manual, further information may be demanded from the manufacturer.

This operating manual is in accordance with the relevant valid EN safety standards and the valid prescriptions and rules of the Federal Republic of Germany.

If the solenoids are used abroad of the FRG, the operator and/or the person who is responsible for the plant concept must take care that the valid national rules are met.

The manufacturer reserves the right of any technical change and improvement.

The use of these operating instructions suppose the qualification of the user according to paragraph 2.3 "qualified staff".

The operating staff must be trained in accordance with the operating instructions. The operating manual must always be available at the location where used.

1.1 Valve data

Manufacturer:

UNI Geräte E. Mangelmann
Elektrotechnische Fabrik GmbH
Holtumsweg 13
D-47652 Weeze
Phone: +49 (0) 2837/9134-0
Fax: +49 (0) 2837/1444
E-Mail: info@uni-geraete.de
Homepage: www.uni-geraete.de

Designation

Directly functioning, currentless closed, spring shut off valve with magnet drive.

Test basis:

DIN EN ISO 23553-1
DIN EN 16678, DIN EN 13611
DIN EN 12266-1

Type:	Working pressure	Ambient temperature	Medium	Medium temperature	Test pressure (*) PT
16- EVS...	16 bar	-10°C to +60°C	Propan, Butan	-30°C to +120°C	PT 24
16- EVS...*	16 bar	-20°C to + 60°C	demineral water	-20°C to + 60°C	PT 24
25- EVS...	25 bar	-20°C to +60°C	Propan, Butan	-30°C to +120°C	PT 37,5
25- EVS..N(H).Xde	25 bar	-20°C to +60°C	Propan, Butan	-20°C to +120°C	PT 37,5
40- EVS...	40 bar	-20°C to +50°C	Propan, Butan	-30°C to +140°C	PT 60
120- EVS...	120 bar	-20°C to +60°C	Natural gas	-20°C to + 60°C	PT 180
135- EVS 12...*	10 bar	-20°C to +60°C	Fuel oil, Water	< 80°C	PT 203
135- EVS 15...*	12 bar	-20°C to +60°C	Fuel oil, Water	< 80°C	PT 203
160- EVS 15...*	20 bar	-20°C to +60°C	Fuel oil EL, Water	+60°C	PT 240

(*) Test pressure to perform leakage test "No FUNCTION TEST"

Fitting position: vertical or horizontal drive.

Fitting position ...*: vertical drive.

Switching cycles: see operating instructions solenoid drive

Threaded connection dimension at DIN ISO 228-1

Connection G	1/4 (2)	3/8 (3)	1/2 (5)	3/4 (7)	1 (10)	1 1/4 (12)	1 1/2 (15)	2 (20)
120-EVS	-	-	O	-	-	-	-	-
135-EVS	-	-	-	-	-	O	O	-
160-EVS	-	-	-	-	-	-	O	-

O Acceptance test certificate 3.2 possible, - not available,

Flange connection measures acc. to DIN EN 1092-1 / ANSI 300lbs

Flange DN	PN	15 (5N)	20 (7N)	25 (10N)	32 (12N)	40 (15N)	50 (20N)	65 (25N)	80 (30N)	100
16-EVS..N(H)	16/25	-	-	-	O	O	-	-	-	-
25-EVS..N(H)	ANSI 300lbs	-	-	-	O ¹⁾	O ¹⁾	O ¹⁾⁴⁾	-	-	-
25-EVS..N(H).Xde	ANSI 300lbs	-	-	-	O ²⁾	-	O ³⁾	-	-	-
40-EVS..N(H)	40	-	-	O	-	-	-	-	-	-

O Acceptance test certificate 3.2 possible, - not available,

¹⁾ Valve chamber ANSI 300lbs Table 2, row 15, ²⁾³⁾⁴⁾ Valve chamber ANSI 300lbs Table 2, row 21,

Welding ends in accordance with DIN EN 558

Welding ends	PN	15 (5N)	20 (7N)	25 (10N)	32 (12N)	40 (15N)	50 (20N)	65 (25N)	80 (30N)	100
25-EVS..N(H)	40	-	-	-	O ⁵⁾	-	O ⁵⁾	-	-	-

⁵⁾ Valve chamber in accordance with DIN EN 558 series 92

Voltage: VDC 12 – 440 (–15% to +10%)
VAC 24 – 500 (–15% to +10%)

Protection type: IP54 or IP65

Frequency 40 – 60 Hz

Power 10 – 4000W

Details to the electrical data can be found on the type sign and the adequate operating instructions of the solenoid valves.

1.2 Application

The UNI Geräte Electro – Solenoid valves EVS are used as automatic shut-off valves for protection, limitation, shut-off and release of gas and air supply at main stopps or in front of gas burners.

If used in other cases, the operator must carefully check if construction/design of valve, accessories and materials are suitable for the new application. The range of application is subject to the responsibility of the plant planner. The service life of the valve is 20 years.

2.0 Danger Notices

2.1 Safety terms

The signal terms DANGER, CAUTION und NOTICE are used in this operating manual in case of notices concerning special dangers, or for unusual information requiring a special marking.



DANGER! means that in case of non-observance there is danger to life and/or considerable damage.



CAUTION! means that in case of non-observance there is danger of injury and/or damage.



NOTICE! means that attention is drawn to technical correlations/connections.

Observance of other, not especially marked notices concerning transport, assembly, operation and maintenance and other data (in the operating manual, product documentation and at the unit itself) is also essential, in order to avoid disturbances that might affect direct or indirect damage to property or injury to persons.

2.2 Safety notice

Non observance of safety instructions can lead to loss of any claim for damages.

Non observance can lead to the following mentioned dangers:

- Failure of important functions of the valve/plant
- Endangering of persons by electrical or mechanical influences.
- Protection against accidental contact for moving parts may not be removed as long as the valve is in operation.
- Leakage of dangerous media (e.g. explosive, toxic, hot) must be removed in the way that there is no danger for persons or environment. Laws and regulations must be observed.

2.3 Qualified staff

These are persons who are familiar with erection, assembly, starting, operation and maintenance of the product and who have special qualifications acc. to their activities and functions, e.g.:

- Instruction and obligation to carry out and meet all regional and in-house orders and requirements.
- Education or instruction according to the safety engineering standards in use and maintenance of adequate safety and working protection equipment.
- Training in first aid.

2.4 Unauthorized modification and spare part production

Modification or changes of the valve are only allowed after agreement of the manufacturer. Original drawings and accessories authorized by the manufacturer are for safety purposes. The use of other parts or unauthorized changes at the valve by third persons may cancel and abolish the manufacturer's liability for resulting consequences.

2.5 Unauthorized operation

Operational reliability of the delivered valve is only guaranteed in case of determined use in accordance to paragraph 1 of the operating manual. **The application limits mentioned on the type sign may on no account be exceeded.**

2.6 Safety information for the use in explosion-prone areas guideline 2014/34/EU

- The temperature of the medium must not exceed the respective temperature class, and respectively, the respective maximum permitted medium temperature as per operation guideline.
- If the valve is heated (e.g. heating jacket), care must be taken, that the specified temperature class is kept in the time.
- The valve must be connected to the ground.
In the case most simple this can be realized via pipe screws by means of tooth disc.
Otherwise the connection to the ground must be implemented by other measures e.g. cable links.
- Control valves, electrical and electrical/mechanical drives as well as sensors must undergo a separate conformity check as per ATEX. In doing so the respective safety and explosion protection information in the operation instructions are to taken into special consideration.
- Any modifications whatsoever to the valve are not allowed. The ATEX approval is void with immediate effect if the valve is modified without prior authorisation (even including painting).
- UNI- Geräte GmbH must be consulted before any modifications are made.

Furthermore we point out the guideline 1999/92/EC (ATEX 118a), which include the minimum regulations for the improvement of the health-related situation and the safety of the employees, who might be jeopardized by an explosive atmosphere.

2.7 Safety information regarding guideline 2014/68/EU attachment I



Danger!

UNI valves are not an accessory with a safety function as defined in the PED 2014/68 / EU Article 2 (4) and Article 4 (1) (d) by category IV Use or classify!

3.0 Handling

3.1 Transport

For any transport works, the generally recognised technical rules and standards as well as rules for prevention of accidents must be observed.

In case of transport, storage and stopping, protection caps must be attached to the sides of the valve.

The goods to be transported must be carefully treated. During transport, the valve must be protected against strokes, impacts or vibration. The coat of lacquer may not be damaged. Transport temperature is -20°C up to $+60^{\circ}\text{C}$.

Never transport the valve at screwed cable glands, appliance plugs or add-on units. The valve can be transported at ring nuts, flange borings or by means of a belt under the solenoid drive.

Transport the valve in a case or on a pallet with smooth base and put it softly on plain floor. **Never put the valve on attachment parts.**

The goods must be checked on completeness and transport damage. See also section 9.0

3.2 Storage

If the valve is not installed immediately after delivery, it must be stored properly.

- Storage temperature -20°C up to $+60^{\circ}\text{C}$, dry and clean.
- The lacquering protects against corrosion in neutral dry atmosphere. Do not damage colour.
- In humid rooms, a drying agent or a heating resp. is necessary because of condensation of water.

Requirements according to DIN 7716 (products made of caoutchouc and rubber) must be met.

3.3 Handling before mounting

- In case of valve with protection caps, they must be removed before being mounted!
- Protect against atmospheric influences such as humidity.
- Appropriate treatment protects against damage.

4.0 Product Description

The UNI-Geräte Electro – solenoid valve EVS is a directly controlled, currentless closed shut-off valve with solenoid drive.

Sectional drawing 11.1 Fig. 1 - 6 shows the valve construction.

4.1 Function

By switching on the solenoid drive (800), the solenoid core (207) is drawn against the upper part of housing (106). The pressure spring (503) is pressed and the balance piston (220) releases the valve cross section. The valve is open.

The valve closes by switching off, interruption or failure of power energy to solenoid drive. Due to press of the pressure spring (503) the balance piston closes (220). The valve is closed at 15% of nominal voltage.

4.2 Technical data

Opening times: 0,3 – 0,7s
Closing times: < 1s

Solenoid –drive types MG...

Connection G	1/4 (2)	3/8 (3)	1/2 (5)	3/4 (7)	1 (10)	1 1/4 (12)	1 1/2 (15)	2 (20)
120-EVS	-	-	019A5	-	-	-	-	-
135-EVS	-	-	-	-	-	019A5	019A5	-
160-EVS	-	-	-	-	-	-	019A5	-

Flange DN	15 (5N)	20 (7N)	25 (10N)	32 (12N)	40 (15N)	50 (20N)	65 (25N)	80 (30N)	100
16-EVS..N(H)	-	-	-	018	018	-	-	-	-
25-EVS..N(H) ¹⁾⁴⁾⁵⁾	-	-	-	019A5	019A5	019A5	-	-	-
25-EVS..N(H).Xde ²⁾³⁾	-	-	-	019A5	-	019A5	-	-	-
40-EVS..N(H)	-	-	018	-	-	-	-	-	-

Drive types with "A" consist of pickup and holding winding

Max. valve loading by pipe power

The indicated moments may not work longer than 10s.

DN	8	10	15	20	25	32	40	50	65	80	100	125	150
Torsion Nm	20	35	50	85	125	160	200	250 ¹⁾	325 ¹⁾	400 ¹⁾	-	-	-
Bending Nm	35	70	105	225	340	475	610	1100	1600	2400	5000	6000	7600

¹⁾ Not valid in case of valves with flanges

Torque, pipe screws greased

DN	8	10	15	20	25	32	40	50	65	80	100	125	150
Torque Nm	20	30	30	30	30	50	50	50	50	50	80	160	160

Torque, product screws and nuts greased

Screw	M6	M8	M10	M12	M16	M20	M24
Torque Nm	5	11	22	39	70	110	150

4.3 Marking

The type sign on the solenoid drive has the following information:

- Fabricator
- Valve type, nominal width, pressure and temperature indication, fitting position
- Year of construction/ production no.
- CE-sign and no. of relevant location
- Fluid group and test pressure PT
- Solenoid drive type
- Electr. performance
- Voltage
- Frequency
- Protection type

When using solenoid drives for ex-protection zone 1 refer to information in the valid operating instructions.

Refer also to section 10.0.

5.0 Installation

5.1 Warning of dangers during installation, operation and maintenance



DANGER!

Safe operation of the valve can only be guaranteed if it is installed, commissioned and maintained by qualified personnel (see point 2.3 "Qualified staff") correctly and in observance of the warnings in this operating manual. Apart from that, the operation safety order and the qualified use of tools and protection equipment must be guaranteed. The operating instructions for the valve must be observed during all work on or with the valve. Failure to observe these instructions may result in injury or in damage to the valve or other installations.

When the valve is used as a final sealing element, a safety precaution e.g. blanking disc, blind flange, etc., in accordance with the code of practice of the German Technical and Scientific Association for Gas and Water (DVGW) is recommended during all repair work.

5.2 Installation

5.2.1 Generally applicable installation guidelines

Apart from the general installation guidelines, the following points should be observed:



NOTICE!

- Remove the flange covers.
- The inside of the valve and the pipeline must be free from foreign particles.
- Observe the installation position in relation to the flow direction, see markings on the valve.
- Centre gaskets between the flanges.
- The connecting flanges must be aligned.
- Ensure that none of the components is strained during installation.
- The valve must not be used as a fixed point; it is supported by the pipework system.
- Protect valves from soiling, particularly during construction work.
- Thermal expansion of the pipework must be equalized using compensators.



NOTICE!

Please observe the solenoid drive operating instructions.

5.2.2 Installation guidelines for installing valve housings with welding ends



NOTE!

- Electric solenoid valves ..EVS..N(H).. are usually installed in horizontally running pipelines. The flow direction in the pipeline and the direction arrow on the valve housing must be pointing in the same direction.
- The electric solenoid valve can be installed in a vertically arranged pipeline observing the flow direction arrow on the valve housing.



DANGER!

The valve chamber may only be welded in by qualified personnel (see point 2.3 "Qualified personnel") and with an open solenoid valve.

- The valve disk sealing of the balancing piston must not exceed +180°C.
- Carry out the welding procedure at the connecting ends using the valid welding instructions.
- After welding in the electric solenoid valve, the pipeline should be thoroughly flushed with the valve open.
- Carrying out trial runs with contaminated media will damage the sealing system of the electric solenoid valve.
- Check valve for internal and external leaks in accordance with DIN EN 12266-1 and carry out a function test.

6.0 Operation



DANGER!

Before commissioning a new installation or before starting up an installation again after repairs or modifications, ensure:

- The proper completion of all installation and assembly work!
- Commissioning only by “qualified staff” (see point 2.3).
- Installation or repair of existing guards and protection equipment.

6.1 Commissioning

- Before commissioning, check the data on material, pressure, temperature and flow direction with the layout plan of the pipework system.
- Depending on the field of application, the local regulations have to be observed, e.g. the operation safety order.
- Residues in the pipework and the valve (dirt, weld beads, etc.) will inevitably result in leaks.
- Leakage inspection of the installed valve.

6.2 Shutting down

- Depending on the field of application, the local regulations have to be observed, e.g. the operation safety order.

6.3 Maintenance

Solenoid valves have to be checked at regular intervals for proper function and internal leak tightness. The intervals for regular inspections have to be defined by the operator according to the operating conditions. UNI-Geräte recommends an internal visual inspection once a year and an overhaul of the valve after 2 years or after the following number of switching cycles at the latest:

Application temperature	DN ≤ 25	≤ DN 80	≤ DN 150	> DN 150
≤ 25°C	150 000	75 000	25 000	20 000
> 25°C	50 000	25 000	25 000	5 000

Repair or maintenance works at the manufacturing company (UNI- Geräte)

- Valves and fittings must be delivered clean and free from substances which are harmful to health or to the environment.

UNI-Geräte prescribes the following maintenance intervals for valves with SIL requirements:

The safety requirements with regard to the maintenance intervals to be adhered are described in the **SIL manual** of the type series and must be complied with.

6.4 Putting back into operation

When putting a valve back into operation, ensure that all the necessary steps described in section 5.2 (Installation) and section 6.1 (Commissioning) are repeated.

7.0 Troubleshooting

7.1 Detection of defects



DANGER!

Be sure to observe the safety instructions during troubleshooting.

If the malfunctions cannot be remedied using the following **“Troubleshooting plan (7.2)”** please contact the manufacturer.

In the event of faults in the function or operating behaviour of the valve, check whether the installation work was carried out and completed as described in this operating manual.

Depending on the field of application, the operation safety order must be observed.

Check the data on material, pressure, temperature, voltage and flow direction with the layout plan of the pipework system. In addition, check whether the operating conditions correspond to the technical data in the data sheet or on the rating plate.

7.2 Troubleshooting plan

Malfunction	Possible causes	Remedy
No flow	Valve does not open	Switch on solenoid drive (800) Check operating voltage
	Working pressure too high	Compare working pressure with the data on the rating plate
	Protection caps were not removed	Remove protection caps
Low flow rate	Clogging in the pipework system	Check pipework system
Valve leaking at seat, no internal tightness	Valve disc sealing (400) or valve seat (100) damaged by external particles	See section 8 or replace valve
No external tightness	Gaskets damaged	See section 8 or replace valve
Valve does not close	Connected voltage too high	Check whether there is residual voltage, see section 4.1
Flange fracture (valve/pipework)	Screws not tightened uniformly, mating flanges not aligned	Align pipework. Install new valve



NOTICE!

Observe section 9.0 before all installation and repair work!

Observe section 6.4 when putting the valve back into operation!

8.0 Dismantling of the Valve

In addition to the general installation guidelines and the operation safety order, the following points must also be observed:



DANGER!

- Depressurised pipework system
- Cooled medium
- Emptied installation
- Vent pipework systems containing corrosive, inflammable, aggressive or toxic media
- Have dismantling work carried out only by qualified staff (see point 2.3)

8.1 Replacement of Wear Parts

Shut down the valve as described in section 6.2.

Switch off and dismantle the solenoid drive as described in the operating manual of the solenoid drive.



DANGER!

After continuous operation, the solenoid drive may be hot! Danger of burns!

During the visual inspection, pay attention to the following points:

1. Damage to the valve seat (100).
2. Damage to the valve disc sealing (400)
3. Wear of the guide rings (206)

In case of damage to the valve seat, replace the whole magnetic valve.

If the sealing element becomes damaged (only applies to flange version Fig.1), the spare parts kit should be used.

Flanged version

Fig.1¹⁾ 16/25-EVS..N(H)

Loosen set screw (941) and unscrew upper part of housing (106). Remove bolt (902) together with split-pin (912) and place solenoid core (207) together with spring bolt (210), valve pin (214), pressure spring (503), hexagon nut (901/2) and locking plate (908) aside on a clean surface.

Loosen and remove hexagon screw (900) together with lock washer (905). Remove spacer (110) from piston guide (221). Then pull balance piston (220) together with piston guide (221) out of valve chamber (100) and pull apart.

Fig.1²⁾ 25-EVS 12NH.Xde..., Fig.1³⁾ 25-EVS 20N.(Xde)...

Fig.1⁴⁾ 25-EVS 20N...

Fig.1⁵⁾ 25-EVS..N(H)... optional with limit switch mounting

Fig.2 40-EVS..N(H)...

Fig.3 40-EVS..N(H)... optional with limit switch mounting

Replace the complete solenoid valve

Threaded version

Fig.4/5 120-EVS, 135-EVS, 160-EVS

Replace the complete solenoid valve



DANGER!

For special application such as for oxygen use only the approved Lubricants and appropriate sealing materials (Bam-approval).



NOTICE!

Before assembly, replace O-rings (403), lip-rings (404) and scraper rings (405). Lubricate the piston guide with Staburags N32 lubricant. (Does not apply to oxygen!)

Assemble the valve in the reverse order to the dismantling.



CAUTION!

Install wear parts carefully and properly and do not damage them during assembly.

Examine the valve for internal and external leaks in accordance with DIN EN 12266-1 and finally carry out a function test.

9.0 Warranty

Scope and period of the warranty is specified in the edition of the "General Terms of Business of the UNI-Geräte E. Mangelmann Elektrotechnische Fabrik GmbH" valid at the time of delivery or else in the purchase agreement.

We warranty that the valve is free from faults in line with the state of the art and for the confirmed field of application.

No warranty claims will be accepted for damage resulting from improper use or failure to observe these operating and installation instructions, the statutory accident prevention regulations, the EN, DIN and VDE standards and other codes and regulations.

Warranty claims will also not be accepted for damage occurring during operation due to operating conditions deviating from those specified in the data sheet or in other agreements.

Justified complaints will be remedied by reworking by us or specialist companies authorised by us.

Claims going beyond the scope of the warranty will not be accepted. The customer shall have no right to the supply of a replacement valve.

Maintenance work, installation of parts from other manufacturers, any modifications to the design and natural wear are not covered by the warranty.

Transport damage must be reported not to us but **without delay** to your responsible goods handling company, the railway company or the shipping agent as otherwise all claims for damages against these companies will be voided.

10.0 Explanations on Codes and Directives

The Commission of the European Union has laid down common directives for the free trading of goods within the Union specifying minimum requirements for safety and health protection. The CE symbol confirms that products comply with the EU directives, i.e. in conformity with the relevant, in particular harmonised standards. Relevant Directive is 2014/68/EU for the solenoid valve (mechanical part).

Notes on Directive 2014/68/EU (Pressure Equipment Directive, DGRL):

It has been conformed that the quality assurance in design control, manufacture and final acceptance of the manufacturer, UNI-Geräte E. Mangelmann Elektrotechnische Fabrik GmbH, satisfy the requirements of 2014/68/EU Article 14 Module H. The gas solenoid valves comply with the fundamental requirements of Directive 2014/68/EU. Valves in according to Article 1 Paragraph 2,f,v or Article 4 paragraph 3 are not allowed to have the CE Mark in according to Article 18.

Note concerning ex-guideline 2014/34/EU (explosion guideline ATEX):

The product is not subject to guideline 2014/34/EU, since due to the loads occurring during practical operation, there is no effective source of ignition even in case of an error case to be assumed. This also applies to spring loaded components in gas-filled rooms. In case of electric drives, sensors or other electric components the application as per 2014/34/EU is to be checked separately.

11.0 Drawing

11.1 Fig. 1¹⁾ 16/25-EVS..N(H) (Valve chamber at ANSI 300lbs Table 2, row 15)

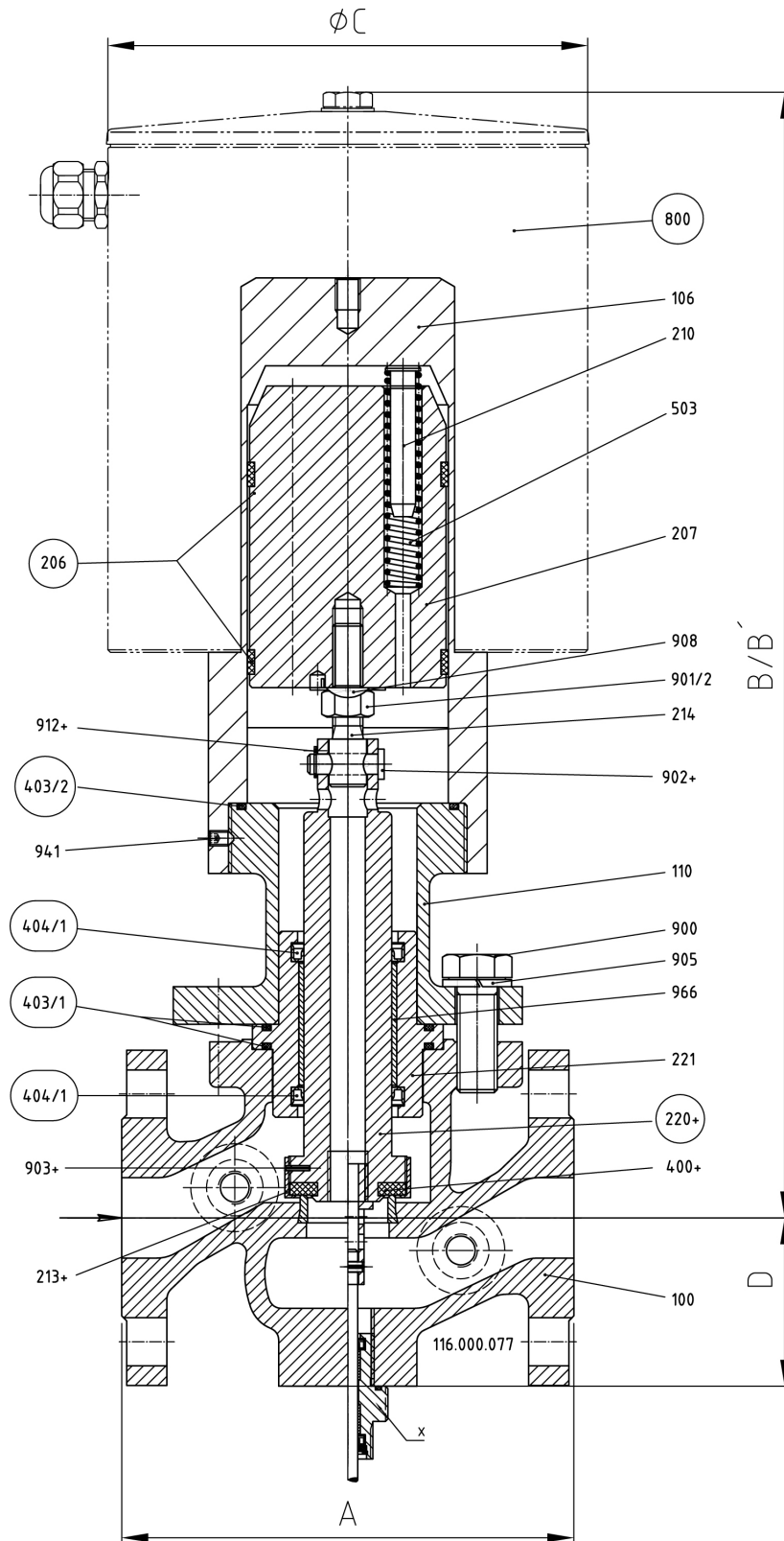

 = Spare parts

X = Option limit switch mounting

(....+) are supplied as a complete unit

Fig. 1²⁾ 25-EVS 12NH.Xde... (Valve chamber at ANSI 300lbs Table 2, row 21)

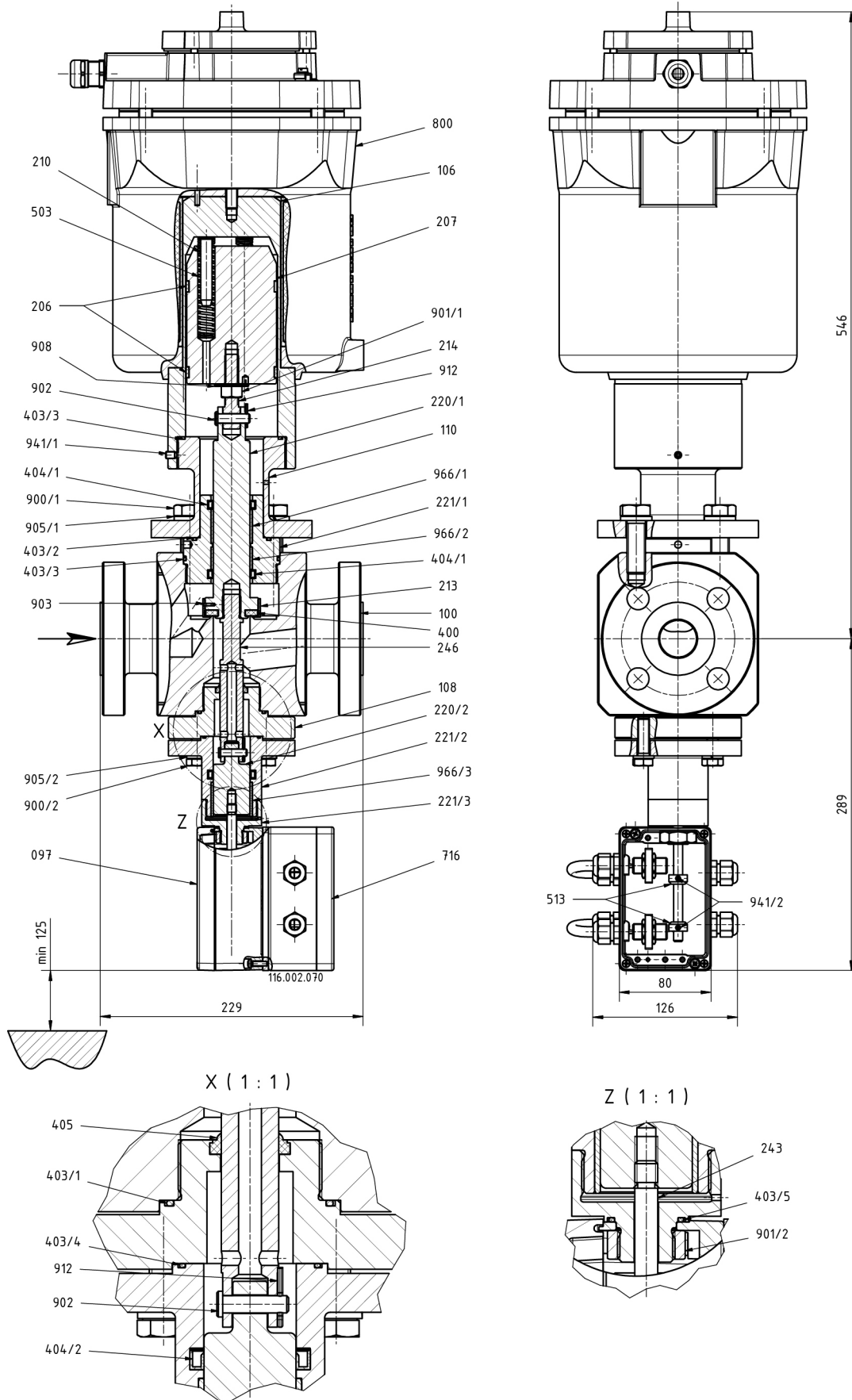

Fig. 1³⁾ 25-EVS 20N..(Xde)... (Valve chamber at ANSI 300lbs Table 2, row 21)

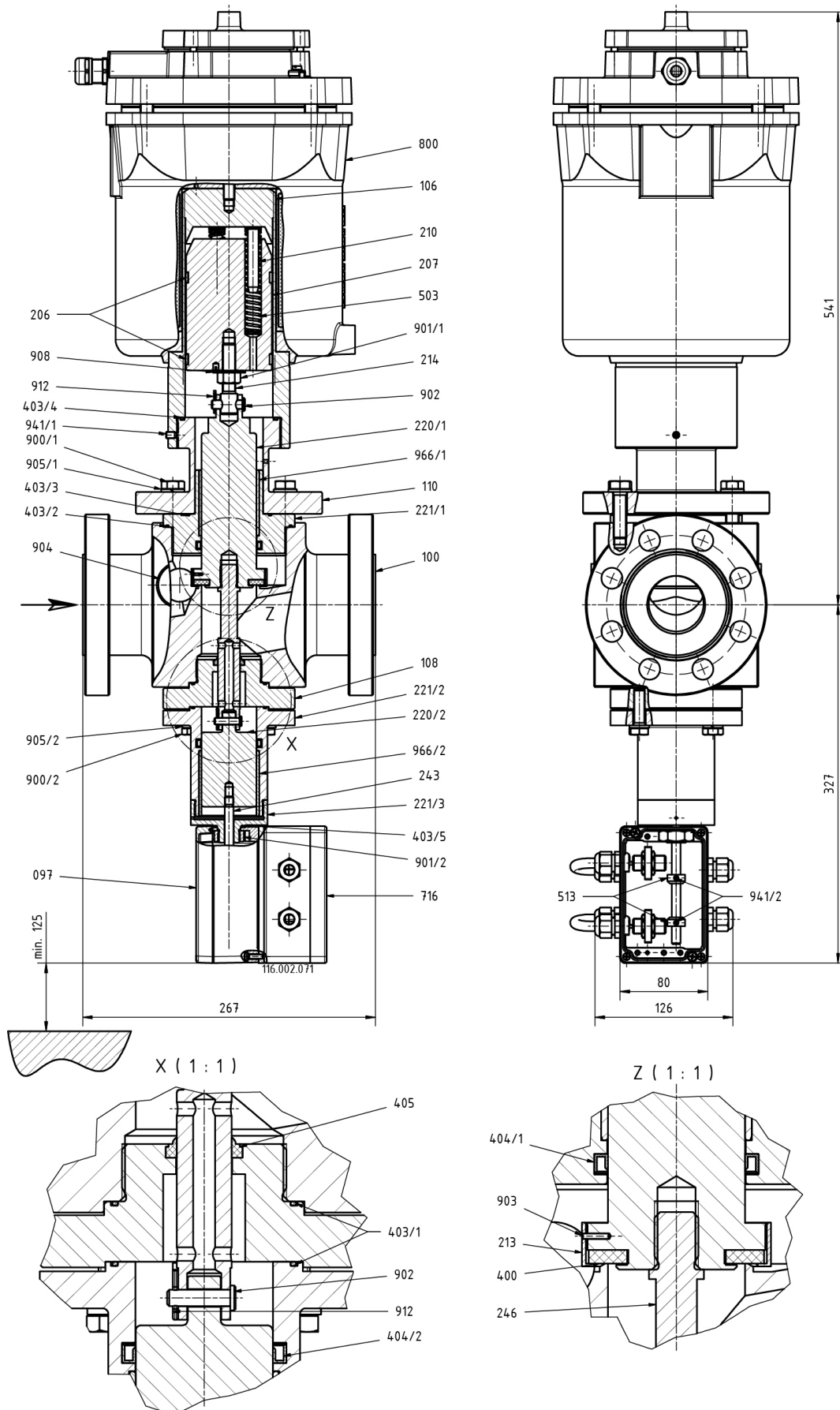

Fig. 1⁴⁾ 25-EVS 20N... (Valve chamber at ANSI 300lbs Table 2, row 21)

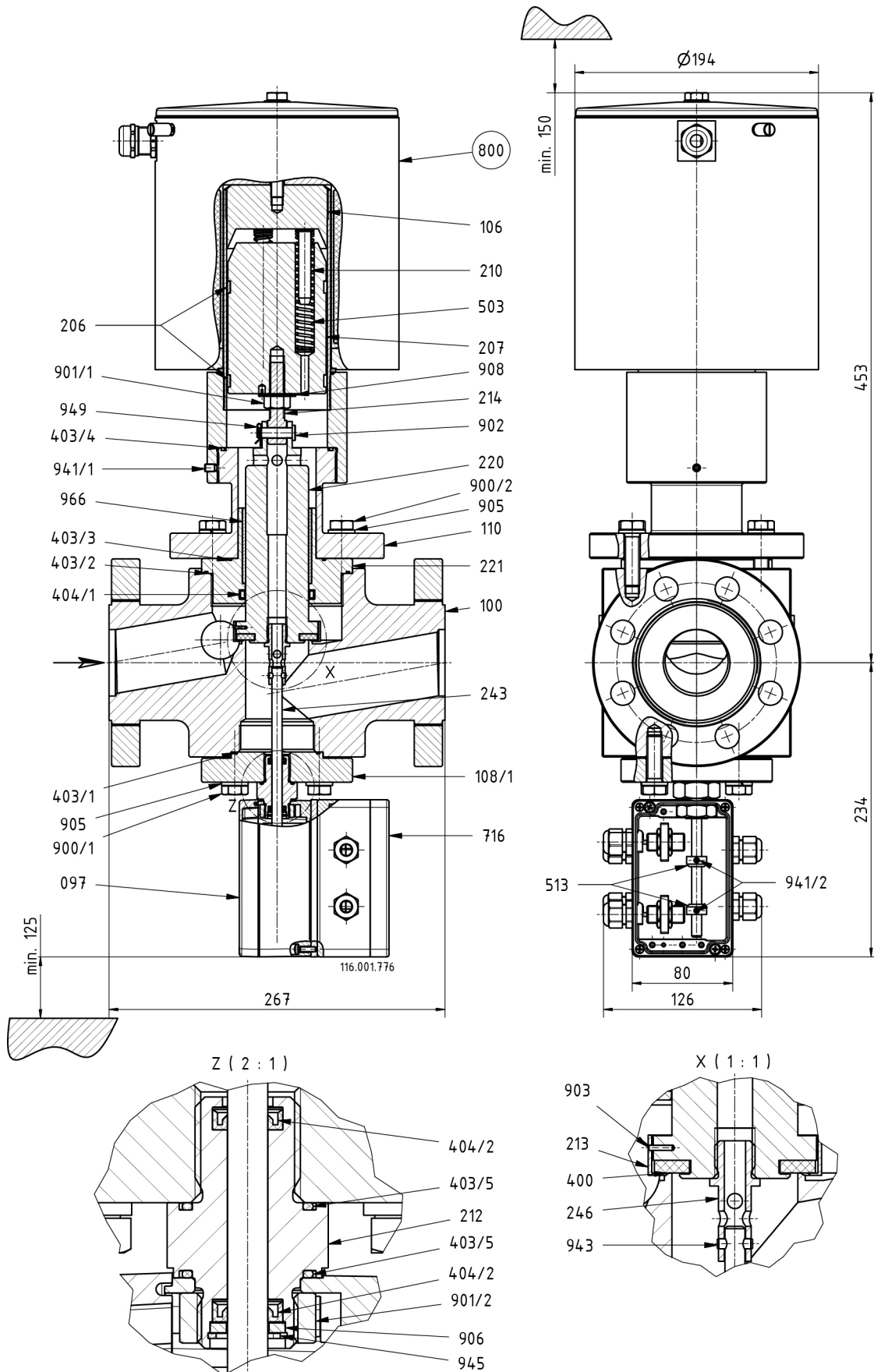

Fig. 1⁵⁾ 25-EVS ...N(H).. (Valve chamber at DIN EN 558, row 92)

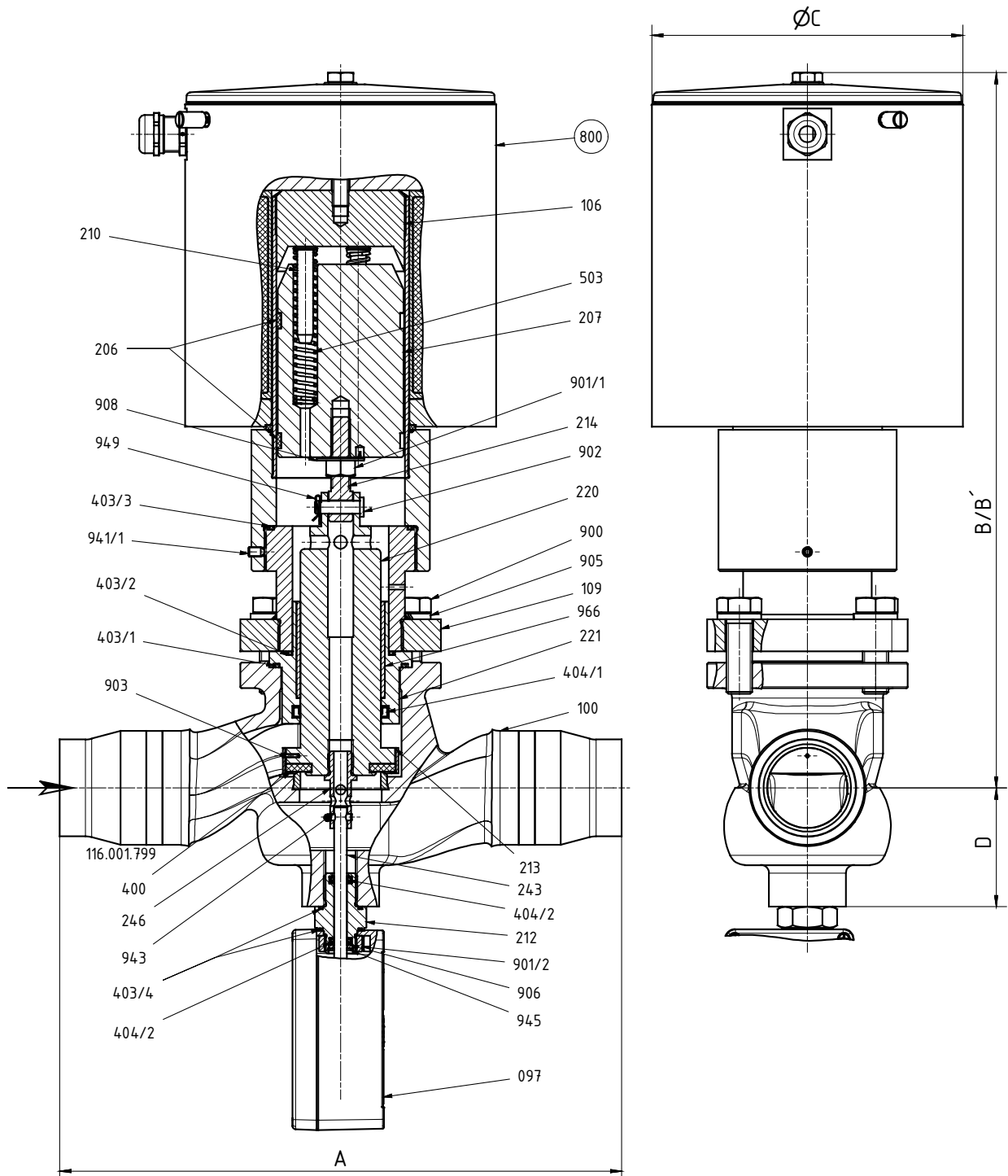
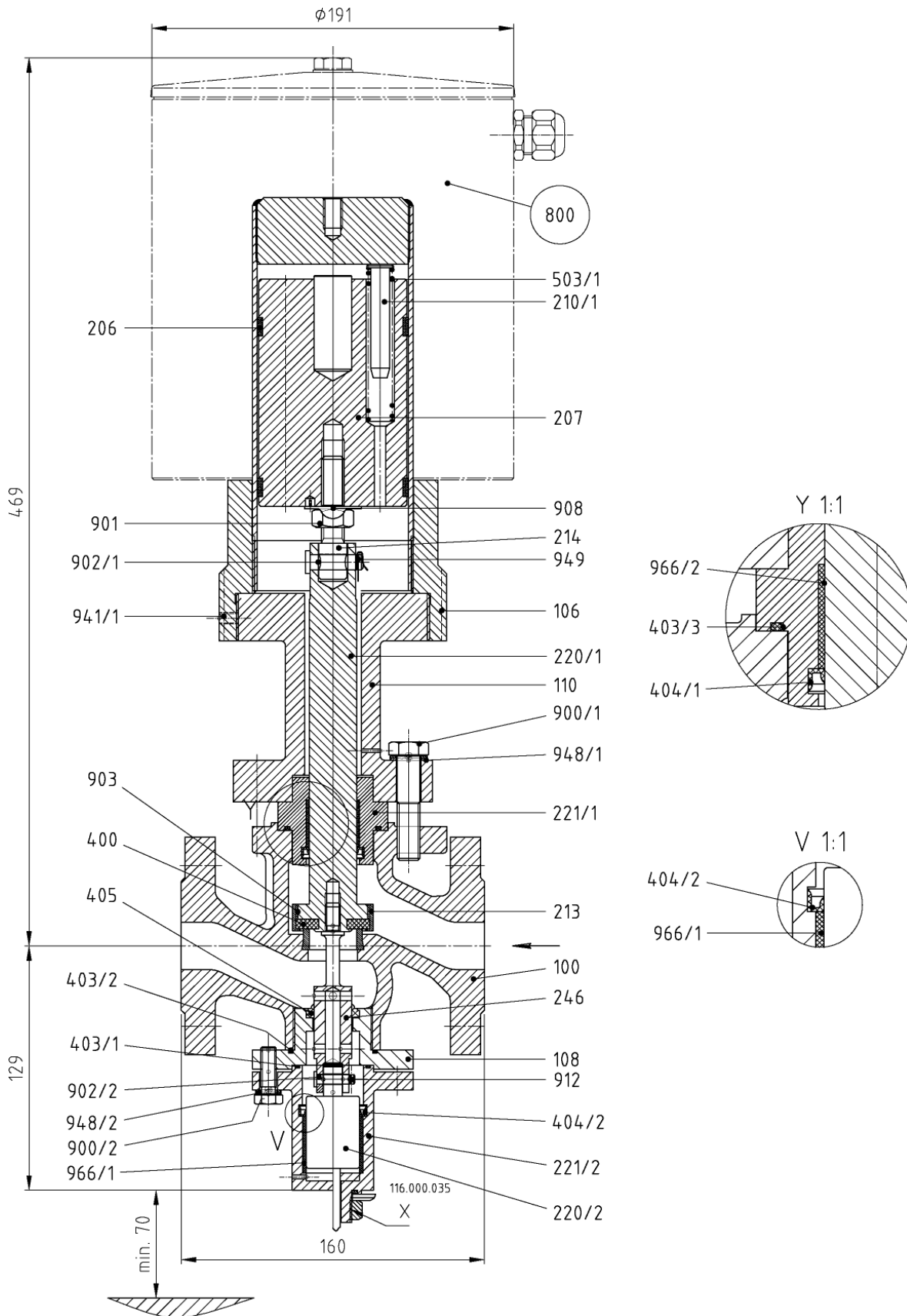

Fig. 2 40-EVS..N(H)



X = Option limit switch mounting

Fig. 3 40-EVS..N(H) option with limit switch mounting

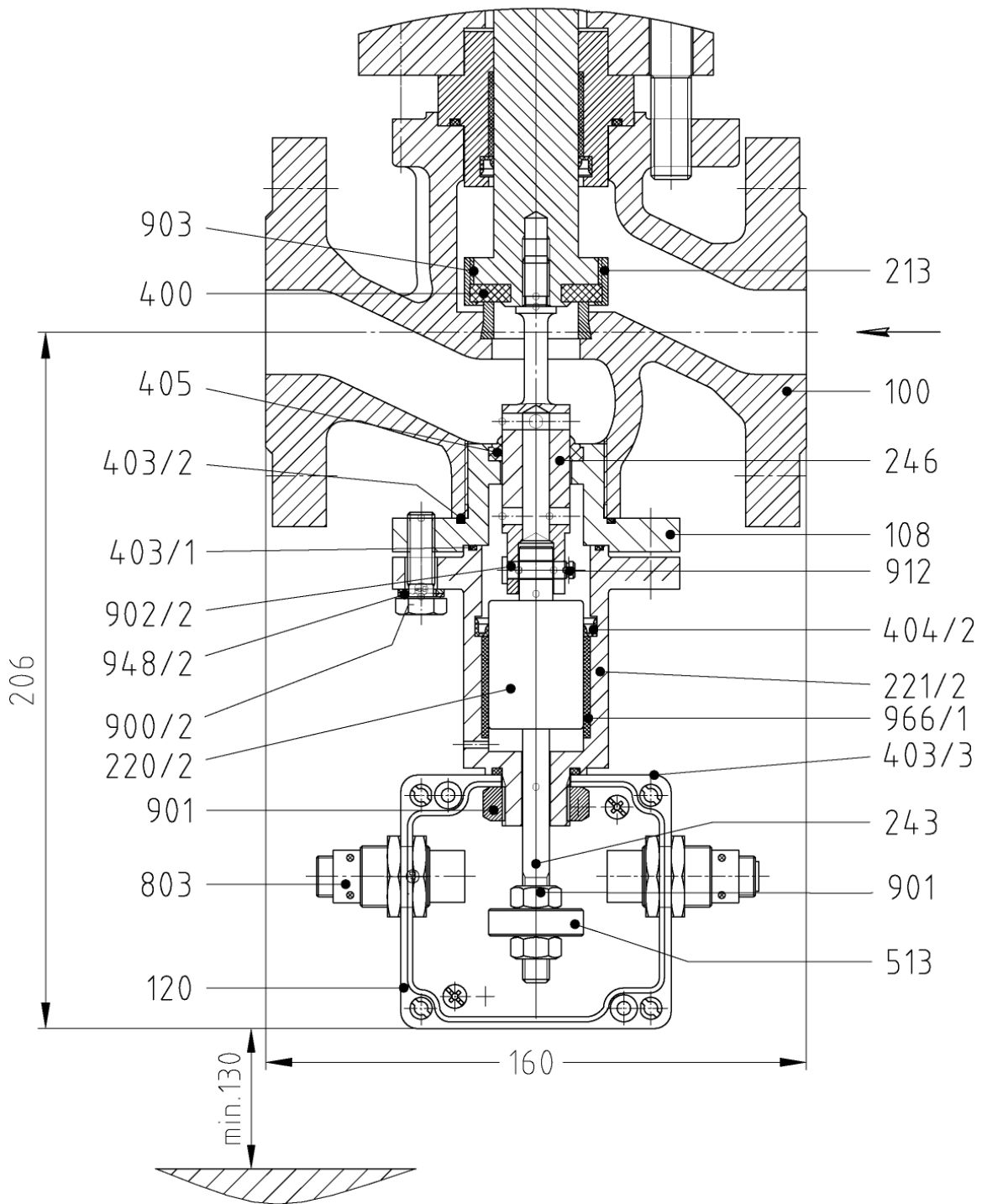

Fig. 4 120-EVS 5...; 135-EVS 12/10..

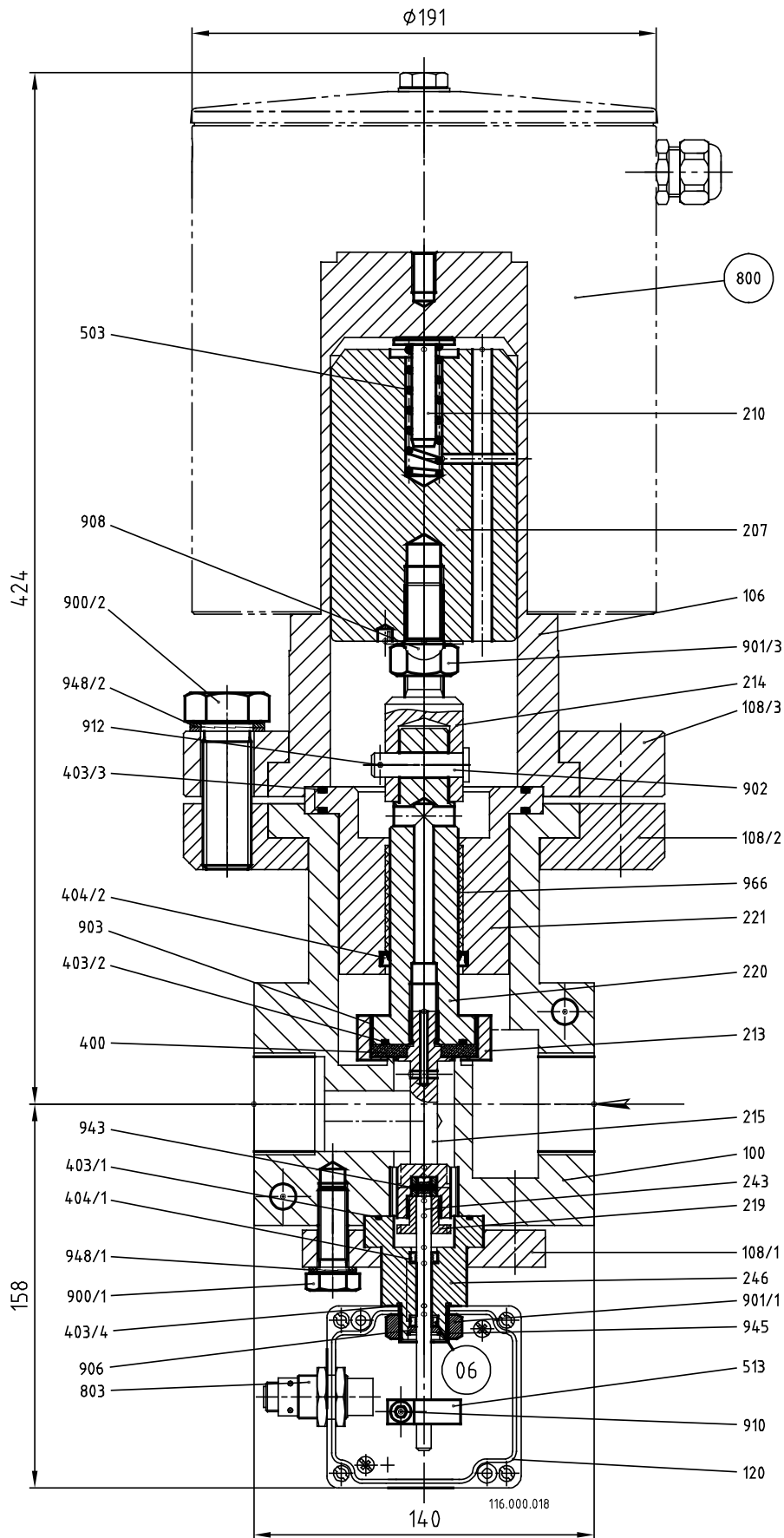
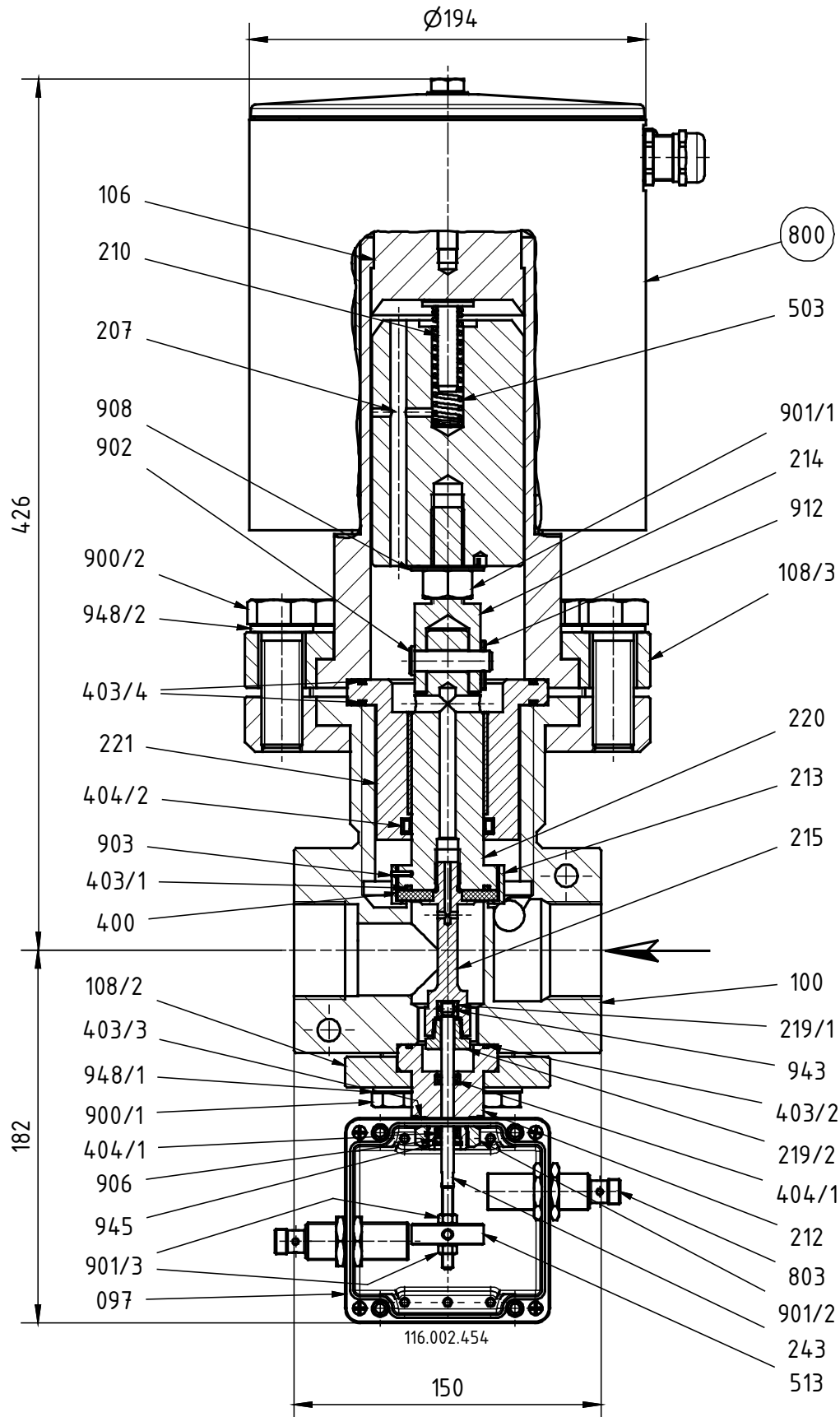

Fig. 5 135-EVS 15.., 160-EVS 15..



11.2 List of parts

Pos./ Item	Stück/ Qty.	Benennung	Description
097	1	Endschalteranbau	limit switch mounting
100	1	Ventilgehäuse	valve chamber
106	1	Oberteil	upper part of housing
108/x	1	Gehäuseflansch	housing flange
109	1	Gehäusezylinder	housing cylinder
110	1	Distanzstück	spacer
120	1	Endschaltergehäuse	limit switch housing
206	2	Führungsring	guide ring
207	1	Magnetkern	solenoid core
210/x	1/3/x	Federbolzen	spring bolt
212	1	Spindelführung	spindle guide
213	1	Gewinding	ring nut
214	1	Ventilstift	valve pin
215	1	Tellerschraube	plate screw
219/x	1	Spindelmutter	spindle nut
220/x	1	Ausgleichskolben	balance piston
221/x	1	Kolbenführung	piston guide
243	1	Endschalterspindel	limit switch spindle
246	1	Verbindungsstück	connecting piece
400	1	Ventiltellerdichtung	valve disc sealing
403/x	1/2	O-Ring	o-ring
404/x	1/2	Lippenring	lip-ring
405	1	Abstreifring	scraper ring
503/x	1/3/x	Druckfeder	pressure spring
513	1/2	Endschalterbetätigung	switch actuator
716	1	Klemmkasten	terminal box
800	1	Magnet-Antrieb	solenoid drive
803	1/2	Endschalter	limit switch
900/x	4/8/x	Sechskantschraube	hexagon screw
901/x	1/2	Sechskantmutter	hexagon nut
902/x	1/2	Bolzen	bolt
903	1	Kerbstift	grooved dowel pin
905/x	4/x	Federring	lock washer
906	1	Scheibe	washer
908	1	Sicherungsblech	locking plate
910	1	Zylinderschraube	cylinder head screw
912	1/2	Splint	split pin
941/x	1/2	Gewindestift	setscrew
943	1	Spannstift	spring dowel sleeve
945	1	Sicherungsring	safety ring
948/x	4/8/x	Nordlockscheibe	nordlock washer
949	1	SL-Sicherung	SL-retainer
966/x	1	DU-Buchse	DU-liner

/x = Quantity varies depending on the valve design

Spare parts

Version	Fig.	Type	Spare parts
Flange version	Fig.1 ¹⁾	16- EVS ...N(H) 25- EVS 12N(H) – 20N(H)	Spare part kit, Solenoid drive (800)
	Fig. 1 ^(3)) 4)5)	25-EVS...N(H)...	Solenoid drive (800)
	Fig.2	40- EVS 10NH...	Solenoid drive (800)
Thread version	Fig.4	120-EVS 5... 135-EVS 12/10...	Solenoid drive (800)
	Fig.5	135-EVS 15., 160-EVS 15..	Solenoid drive (800)

Dimension with standard solenoid drive

Flange DN	Dimension	15	20	25	32	40	50	65	80	100	125	150
Installation length	A ¹⁾	130	150	160	180	200	230	290	310	350	400	480
Flange ASME	Dimension	1/2"	3/4"	1"	1 1/4"	1 1/2"	2"	2 1/2"	3"	4"	-	6"
Installation length	A ²⁾	108	118	127	140	165	203	216	241	292	-	406
16-EVS..N(H)	B	-	-	-	450	480	-	-	-	-	-	-
	B`	-	-	-	610	680	-	-	-	-	-	-
	ØC	-	-	-	194	194	-	-	-	-	-	-
	D	-	-	-	68	68	-	-	-	-	-	-
25-EVS..N(H)	B	-	-	-	450	450	460	-	-	-	-	-
	B`	-	-	-	610	610	620	-	-	-	-	-
	ØC	-	-	-	194	194	194	-	-	-	-	-
	D	-	-	-	68	68	75	-	-	-	-	-

Dimension with welding end DIN EN 558

Welding ends	Dimension	15	20	25	32	40	50	65	80	100	125	150
Installation length	A	250	250	275	300	300	350	450	500	550	600	700
25-EVS..N(H)	B	-	-	-	445	-	445	-	-	-	-	-
	B`	-	-	-	605	-	605	-	-	-	-	-
	ØC	-	-	-	194	-	194	-	-	-	-	-
	D	-	-	-	67	-	74	-	-	-	-	-

A¹⁾ = Dimension at DIN (resp. flanges ANSI and dimension DIN or flanges and dimension at DIN)

A²⁾ = Dimension at ANSI 150lbs (see data sheet on our website armature installation length 225 100 026)

B` = Dimension for removing the solenoid drive

Dimensions B and Ø C change for solenoid drives for explosion-proof zone 1.

12.0 Declaration of Conformity

UNI-Geräte E. Mangelmann
Elektrotechnische Fabrik GmbH
Holtumsweg 13
D – 47652 Weeze



EU Konformitätserklärung Declaration of Conformity

Produkt <i>Product</i>	Sicherheitsabsperrentil <i>Safety shut-off valve</i>
Handelsbezeichnung <i>Trade Mark</i>	Magnetventil <i>Solenoid Valve</i>
Baureihe / <i>Series</i>	16-EVS.. ; 25-EVS..; 40-EVS...
Nennweiten / <i>Size</i>	DN 32 – DN 100
Fluidgruppe <i>Fluid group</i>	Brennbare Gase, FL. Gr.1 <i>Flammable gases, FL. Gr.1</i>
EU - Richtlinien <i>EU - Directives</i>	2014/68/EU Druckgeräterichtlinie / <i>Pressure Equipment Directive</i>
Konformitätsbewertungsverfahren <i>Conformity Assessment Procedure</i>	Modul H 2014/68/EU
Angewandte technische Spezifikation <i>Applied Technical Specification</i>	DIN EN 16678, DIN EN 13611 AD 2000, EN 12516, EN 12266-1
Überwachungsverfahren <i>Surveillance Procedure</i>	CE-0062-PED-H-UGM 001-20-DEU 2014/68/EU Modul H Bureau Veritas Services SAS 8 Cours du Triangle 92800 PUTEAUX – LA DEFENSE Zertifizierungsstelle / <i>Notified Body 0062</i>
Kennzeichnung <i>Marking</i>	CE - 0062 ¹⁾

Das Unternehmen UNI Geräte E. Mangelmann Elektrotechnische Fabrik GmbH erklärt in alleiniger Verantwortung, dass die o.a. Baureihe die grundsätzlichen Anforderungen der aufgeführten Richtlinien und Normen erfüllt.

UNI Geräte E. Mangelmann Elektrotechnische Fabrik GmbH confirms under the sole responsibility of the manufacturer, that the basic requirements of the above specified directives and standards are fulfilled.

Weeze, 14.05.2020



Geschäftsführer
Norbert Schneider
Managing Director

¹⁾ \geq DN32 + \geq 0,6bar, siehe Diagramm 6, fallen in den Anwendungsbereich der 2014/68/EU
 \geq DN32 + \geq 0,6bar, see Diagram 6, are included in the EC-Directive 2014/68/EU

UNI-Geräte E. Mangelmann
Elektrotechnische Fabrik GmbH
Holtumsweg 13
D – 47652 Weeze

EU Konformitätserklärung Declaration of Conformity

Produkt <i>Product</i>	Sicherheitsabsperrventil <i>Safety shut-off valve</i>
Handelsbezeichnung <i>Trade Mark</i>	Magnetventil <i>Solenoid Valve</i>
Baureihe / <i>Series</i>	135-EVS..., 160-EVS...
Nennweiten / <i>Size</i>	G 1 1/4 – G 2"
Fluidgruppe <i>Fluid group</i>	Brennbare Flüssigkeiten, FL. Gr.1 <i>Flammable Liquids, FL. Gr.1</i>
EU - Richtlinien <i>EU - Directives</i>	2014/68/EU Druckgeräterichtlinie / <i>Pressure Equipment Directive</i>
Konformitätsbewertungsverfahren <i>Conformity Assessment Procedure</i>	Modul H 2014/68/EU
Angewandte technische Spezifikation <i>Applied Technical Specification</i>	DIN EN ISO 23553-1 AD 2000, EN 12516, EN 12266-1
Überwachungsverfahren <i>Surveillance Procedure</i>	CE-0062-PED-H-UGM 001-20-DEU 2014/68/EU Modul H Bureau Veritas Services SAS 8 Cours du Triangle 92800 PUTEAUX – LA DEFENSE Zertifizierungsstelle / <i>Notified Body 0062</i>
Kennzeichnung <i>Marking</i>	CE - 0062 ¹⁾

Das Unternehmen UNI Geräte E. Mangelmann Elektrotechnische Fabrik GmbH erklärt in alleiniger Verantwortung, dass die o.a. Baureihe die grundsätzlichen Anforderungen der aufgeführten Richtlinien und Normen erfüllt.

UNI Geräte E. Mangelmann Elektrotechnische Fabrik GmbH confirms under the sole responsibility of the manufacturer, that the basic requirements of the above specified directives and standards are fulfilled.

Weeze, 14.05.2020

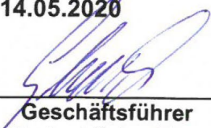

Geschäftsführer
Norbert Schneider
Managing Director

¹⁾ PS*DN < 2000, siehe Diagramm 8, fallen nicht in den Anwendungsbereich der 2014/68/EU
*PS*DN < 2000, see diagram 8, are not included in the EC-Directive 2014/68/EU*