

Operating and mounting manual gas – pneumatic valve EPV(O)...(N)R

Contents

1.0 General remarks

- 1.1 Valve data
- 1.2 Application

2.0 Danger Notices

- 2.1 Safety terms
- 2.2 Safety notice
- 2.3 Qualified staff
- 2.4 Unauthorized modification and spare part production
- 2.5 Unauthorized operation
- 2.6 Safety information for the use in explosion-prone areas guideline 94/9/EC

3.0 Handling

- 3.1 Transport
- 3.2 Storage
- 3.3 Handling before mounting

4.0 Product Description

- 4.1 Function
- 4.2 Technical Data
- 4.3 Marking

5.0 Installation

- 5.1 Warning of dangers during installation, operation and maintenance
- 5.2 Installation

6.0 Operation

- 6.1 Commissioning
- 6.2 Shutting down
- 6.3 Maintenance
- 6.4 Putting back into operating

7.0 Troubleshooting

- 7.1 Detection of defects
- 7.2 Troubleshooting plan

8.0 Dismantling of the Valve

- 8.1 Replacement of wear parts

9.0 Warranty

10.0 Explanations on Codes and Directives

11.0 Drawing

- 11.1 Flange design / Thread design
- 11.2 Projection
- 11.3 Control valve
- 11.4 List of parts

12.0 Declaration of Conformity

1.0 General Remarks

This operating manual includes instructions to assemble and operate the valve in the prescribed and safe way. **Additionally and in accordance with the solenoid drive of the control valve (805), the relevant manufacturer's operating instructions (BTA) must be taken into consideration.**

If any difficulties appear that can not be solved by means of the operating manual, further information may be demanded from the manufacturer.

This operating manual is in accordance with the relevant valid EN safety standards and the valid prescriptions and rules of the Federal Republic of Germany. If the solenoids are used abroad of the FRG, the operator and/or the person who is responsible for the plant concept must take care that the valid national rules are met. The manufacturer reserves the right of any technical change and improvement. The use of these operating instructions suppose the qualification of the user according to paragraph 2.3 "qualified staff".

The operating staff must be trained in accordance with the operating instructions. The operating manual must always be available at the location where used.

1.1 Valve data

Manufacturer:

UNI Geräte E. Mangelmann
Elektrotechnische Fabrik GmbH
Holtumsweg 13
D-47652 Weeze
Telefon: +49 (0) 2837/9134-0
Fax: +49 (0) 2837/1444
E-Mail: info@uni-geraete.de
Homepage: www.uni-geraete.de

Designation

Directly functioning, currentless open, spring-loaded gas shut-off valve with pneumatic drive.

Type test acc. to EU2016/426
DIN EN 16304 Gr. 2
DIN EN 16678 Kl. 0

Working pressure

1-4 EPV(O)..NHR..	0 - 1bar
3-4 EPV(O)..NHR..	0 - 3bar
5-4 EPV(O)..NHR..	0 - 5bar
6-4 EPV(O)..NHR..	0 - 6bar
10-4 EPVO..N(H)-4R	0 - 10bar

Medium temperature: -20°C to + 60°C

Working pressure 63--4 EPVO..N-4R.. 0 - 63bar

Medium temperature: -20°C to + 150°C

Ambient temperature: -20°C to + 60°C

Fitting position: vertical or horizontal drive.

Switching cycles: 500 cycles/h

Flange connection measures acc. to DIN EN 1092-2 / ANSI

Flange DN	PN	Prod. Id. CE-0085	15	20	25	40	50	65	80	100	150	Test pressure (*) PT
Flange ANSI	ANSI		1/2"	3/4"	1"	1 1/2"	2"	2 1/2"	3"	4"	6"	
1-4-EPV(O)..NHR..	16	-	-	-	-	-	-	-	O	-	O	PT 6
3-4-EPV(O)..NHR..	16	-	-	-	-	O	-	-	-	O	-	PT 6
5-4-EPV(O)..NHR..	16	-	-	-	-	-	-	-	O	-	-	PT 10
6-4-EPV(O)..NHR..	16	-	-	-	-	-	-	O	-	-	-	PT 10
10-4-EPVO..N(H)-4R	16	AS0513	O	O	X	O	X	X	-	-	-	PT 16

Flange DN	PN	Prod. Id. CE-0085	15	20	25	40	50	65	80	100	150	Test pressure (*) PT
Flange ANSI	ANSI		1/2"	3/4"	1"	1 1/2"	2"	2 1/2"	3"	4"	6"	
63-4-EPVO...N-4R..	63	AS0513	X	X	-	-	-	-	-	-	-	PT 63

Threaded connection dimension to DIN 2999 Part 1

Thread G	PN	Prod. Id. CE-0085	1/2	3/4	Test pressure (*) PT
10-4-EPVO...4R..	16	AS0513	-	X	PT 16

(*) Test pressure to perform leakage test "No FUNCTION TEST"

X Type test to EU2016/426, O Acceptance test certificate 3.2 possible, - not available

Control medium: Air, nitrogen -20°C up to + 60°C
Control pressure: Min. control pressure, second number on type plate
 Max. control pressure 10bar, e.g. 4-10bar
Electric connection control valve: Notice instructions on type plate of control valve

1.2 Application

The UNI Geräte gas – pneumatic valves EPV(O)..(N)H)..R.. are used to control gas fittings for leakages and to blow off excess or leak gas for example according, to DIN EN 746-2.

The valves are suitable for gases of the 1st, 2nd and 3rd gas families to G260 and for neutral gases and as a variant with material design for aggressive gases such as e.g. biogas, sewage plant gas or dump gas to G262.

If used in other cases, the operator must carefully check if construction/design of valve, accessories and materials are suitable for the new application. The range of application is subject to the responsibility of the plant planner. The service life of the valve is 20 years.

2.0 Danger Notices

2.1 Safety terms

The signal terms DANGER, CAUTION und NOTICE are used in this operating manual in case of notices concerning special dangers, or for unusual information, requiring a special marking.



DANGER! means that in case of non-observance there is danger to life and/or considerable damage.



CAUTION! means that in case of non-observance there is danger of injury and/or damage.



NOTICE! means that attention is drawn to technical correlations/connections.

Observance of other, not especially marked notices concerning transport, assembly, operation and maintenance and other data (in the operating manual, product documentation and at the unit itself) is also essential, in order to avoid disturbances that might affect direct or indirect damage to property or injury to persons.

2.2 Safety notice

Non observance of safety instructions can lead to loss of any claim for damages.

Non observance can lead to the following mentioned dangers:

- Failure of important functions of the valve/plant
- Endangering of persons by electrical or mechanical influences.

- Protection against accidental contact for moving parts may not be removed as long as the valve is in operation.
- Leakage of dangerous media (e.g. explosive, toxic, hot) must be removed in the way that there is no danger for persons or environment. Laws and regulations must be observed.

2.3 Qualified staff

These are persons who are familiar with erection, assembly, starting, operation and maintenance of the product and who have special qualifications acc. to their activities and functions, e.g.:

- Instruction and obligation to carry out and meet all regional and in-house orders and requirements.
- Education or instruction according to the safety engineering standards in use and maintenance of adequate safety and working protection equipment.
- Training in first aid.

2.4 Unauthorized modification and spare part production

Modification or changes of the valve are only allowed after agreement of the manufacturer. Original drawings and accessories authorized by the manufacturer are for safety purposes. The use of other parts or unauthorized changes at the valve by third persons may cancel and abolish the manufacturer's liability for resulting consequences.

2.5 Unauthorized operation

Operational reliability of the delivered valve is only guaranteed in case of determined use in accordance to paragraph 1 of the operating manual. **The application limits mentioned on the type sign may on no account be exceeded.**

2.6 Safety information for the use in explosion-prone areas guideline 2014/34/EU

- The temperature of the medium must not exceed the respective temperature class, and respectively, the respective maximum permitted medium temperature as per operation guideline.
- If the valve is heated (e.g. heating jacket), care must be taken, that the specified temperature class is kept in the time.
- The valve must be connected to the ground.
In the case most simple this can be realized via pipe screws by means of tooth disc.
Otherwise the connection to the ground must be implemented by other measures e.g. cable links.
- Control valves, electrical and electrical/mechanical drives as well as sensors must undergo a separate conformity check as per ATEX. In doing so the respective safety and explosion protection information in the operation instructions are to taken into special consideration.
- Any modifications whatsoever to the valve are not allowed. The ATEX approval is void with immediate effect if the valve is modified without prior authorisation (even including painting).
- UNI-Geräte GmbH must be consulted before any modifications are made.

Furthermore we point out the guideline ATEX 118a, which include the minimum regulations for the improvement of the health-related situation and the safety of the employees, who might be jeopardized by an explosive atmosphere.

3.0 Handling

3.1 Transport

For any transport works, the generally recognised technical rules and standards as well as rules for prevention of accidents must be observed.

In case of transport, storage and stopping, the flange protection caps must be mounted at both valve flanges.

The goods to be transported must be carefully treated. During transport, the valve must be protected against strokes, impacts or vibration. The coat of lacquer may not be damaged. Transport temperature is -20°C up to $+60^{\circ}\text{C}$.

Never transport the valve at pneumatic drive pipings / tubings or components. Transport the valve at provided transport angles (256) from KA120 or ring nut (926) from KA160.

Transport the valve in a box or on a pallet with soft base and put it smoothly on even floor. **Never put valve on the piping/tubing or its components.**

The goods must be checked on completeness and transport damage. See also section 9.0

3.2 Storage

If the valve is not installed immediately after delivery, it must be stored properly.

- Storage temperature -20°C up to + 60°C, dry and clean.
- The lacquer protects against corrosion in neutral dry atmosphere. Do not damage colour.
- In humid rooms, a drying agent or a heating resp. is necessary because of condensation of water.

Requirements according to DIN 7716 (products made of caoutchouc and rubber) must be met.

3.3 Handling before mounting

- In case of valve with protection caps, they must be removed before being mounted!
- Protect against atmospheric influences such as humidity
- Appropriate treatment protects against damage.

4.0 Product Description

The gas – pneumatic valve EPV(O)..(N)H).R... is an automatically directly controlled, currentless open, fast opening blow-off valve according to DIN EN 16304 and DIN EN 16678 with pneumatic drive.

The drive is actuated by a 3/2 way control valve with solenoid drive, type 10-EVD 2 or 10-EVD 2/2401 resp.

The sectional drawing parts 11.1 in Fig. 1 to Fig. 4 shows the valve construction.

4.1 Funktion

On opening the 3/2 way control valve (805) the control medium flows under the drive piston (217) via connection 3 → 2. The control medium presses the drive piston (217) against the pressure spring (503) and closes the pressurized valve disc (200) via the valve spindle (205) (200). The valve is closed.

The valve opens due to shutting off, power failure or interruption of the energy supply to the control valve (805). The compressed control medium in the pneumatic drive is released via the quick venting mechanism (601), the sound absorber (600) and the control valve (805). The drive KA70 is only relieved via the control valve (805).

4.2 Technical data

Opening times: 0,7 – 1s depends upon nominal width

Closing times: < 1s

Drive types and air consumption in standard litre (NL) per connection at 4 bar control pressure.

Flange DN Flange ANSI	15 1/2"	20 3/4"	25 1"	40 1 1/2"	50 2"	65 2 1/2"	80 3"	100 4"	150 6"
1-4-EPV(O)..NHR..	-	-	-	-	-	-	KA 70 1 NL	-	KA 120 5 NL
3-4-EPV(O)..NHR..	-	-	-	KA 70 1 NL	-	-	-	KA 120 5 NL	-
5-4-EPV(O)..NHR..	-	-	-	-	-	-	KA 120 5 NL	-	-
6-4-EPV(O)..NHR..	-	-	-	-	-	KA 120 5 NL	-	-	-

Flange DN Flange ANSI	15 1/2"	20 3/4"	25 1"	40 1 1/2"	50 2"	65 2 1/2"	80 3"	100 4"	150 6"
10-4-EPVO..N(H)-4R.	KA 70 1 NL	KA 70 1 NL	KA 70 1 NL	KA 120 5 NL	KA 120 5 NL	KA 120 5 NL	-	-	-
63-4-EPVO..N-4R..	KA 70 1 NL	KA 70 1 NL	-	-	-	-	-	-	-

Connection G	1/2	3/4
10-4-EPVO..-4R..	-	KA 70 1 NL

Air consumption for 10 bar, multiply control pressure table values by 2.2

Max. valve loading by pipe power to DIN EN 161

The indicated moments may not work longer than 10s.

DN		40	50	65	80	100	125	≥150
Torsion	Nm	200	250 ¹⁾	325 ¹⁾	400 ¹⁾	-	-	-
Bending	Nm	610	1100	1600	2400	5000	6000	7600

¹⁾ Not valid in case of valves with flanges

Starting torque, pipe screws greased

DN		40	50	65	80	100	125	≥150
Torque	Nm	50	50	50	50	80	160	160

Starting torque, product screws and nuts greased

Screw		M6	M8	M10	M12	M16	M20	M24
Torque	Nm	5	11	22	39	70	110	150

4.3 Marking

The type sign on the pneumatic drive has the following information:

- Fabricator
- Valve type, nominal width, pressure and temperature indication, fitting position
- Year of construction/ production no.
- Product ID No. to EU2016/426
- Valve class and valve group acc. to DIN EN 16304, DIN EN 16678
- CE-sign and no. of relevant location to 2009/142/EC
- Fluid group and test pressure PT to 2009/142/EC
- Pneumatic drive type
- Control medium p_{min} and p_{max} for control medium

Refer also to section 10.0.

5.0 Installation

5.1 Warning of dangers during installation, operation and maintenance



DANGER!

Safe operation of the valve can only be guaranteed if it is installed, commissioned and maintained by qualified personnel (see point 2.3 "Qualified staff") correctly and in observance of the warnings in this operating manual. Apart from that, the operation safety order and the qualified use of tools and protection equipment must be guaranteed. The operating instructions for the valve must be observed during all work on or with the valve. Failure to observe these instructions may result in injury or in damage to the valve or other installations.

When the valve is used as a final sealing element, a safety precaution e.g. blanking disc, blind flange, etc., in accordance with the code of practice of the German Technical and Scientific Association for Gas and Water (DVGW) is recommended during all repair work.

5.2 Installation

Apart from the general installation guidelines, the following points should be observed:



NOTICE!

- Remove the flange covers.
- The inside of the valve and the pipeline must be free from foreign particles.
- Observe the installation position in relation to the flow direction, see markings on the valve.
- Centre gaskets between the flanges.
- The connecting flanges must be aligned.
- Ensure that none of the components is strained during installation.
- The valve must not be used as a fixed point; it is supported by the pipework system.
- Protect valves from soiling, particularly during construction work.
- Thermal expansion of the pipework must be equalized using compensators.

In accordance with DIN EN 16678, a dirt trap must be installed upline of any safety shut-off device. The mesh size of the screen must be smaller than 1.5 mm and not allow a test mandrel of 1 mm diameter to pass. Where two safety shut-off devices are combined to form a group, one dirt trap installed upstream of the first valve is sufficient. The dirt trap must be installed not too far upline of the first valve. The UNI Geräte dirt traps of the SFR Series are approved for use together with the gas pneumatic valves in accordance with EU2016/426.

The valve can be installed with vertical or horizontal pneumatic drive. The solenoid drive of the control valve should preferably be installed with vertical drive. The control air must be connected at connection 3. We recommend an air filter in front of the control valve. Mesh size 40 μ m.



NOTICE!

Please observe the control valve operating instructions (BTA).

6.0 Operation



DANGER!

Before commissioning a new installation or before starting up an installation again after repairs or modifications, ensure:

- The proper completion of all installation and assembly work!
- Commissioning only by “qualified staff” (see point 2.3).
- Installation or repair of existing guards and protection equipment.

6.1 Commissioning

- Before commissioning, check the data on material, pressure, temperature and flow direction with the layout plan of the pipework system.
- Depending on the field of application, the local regulations have to be observed, e.g. the operation safety order.
- Residues in the pipework and the valve (dirt, weld beads, etc.) will inevitably result in leaks.
- Leakage inspection of the installed valve.

6.2 Shutting down

- Depending on the field of application, the local regulations have to be observed, e.g. the operation safety order.

6.3 Maintenance

Gas – pneumatic valves have to be checked at regular intervals for proper function and internal leak tightness. The intervals for regular inspections have to be defined by the operator according to the operating conditions. UNI-Geräte recommends an internal visual inspection once a year and an overhaul of the valve after 2 years, except at 63-4-EPVO ... N-4R .. (DN15 and DN20) writes UNI-Geräte an overhaul of the valve once a year, or after the following number of switching cycles at the latest:

Application temperature	DN ≤ 25	≤ DN 80	≤ DN 150	> DN 150
≤ 25°C	150 000	75 000	25 000	20 000
> 25°C	50 000	25 000	25 000	5 000

UNI-Geräte prescribes the following maintenance intervals for valves with SIL requirements:

The safety requirements with regard to the maintenance intervals to be adhered are described in the **SIL manual** of the type series and must be complied with.

6.4 Putting back into operation

When putting a valve back into operation, ensure that all the necessary steps described in section 5.2 (Installation) and section 6.1 (Commissioning) are repeated.

7.0 Troubleshooting

7.1 Detection of defects



DANGER!

Be sure to observe the safety instructions during troubleshooting.

If the malfunctions cannot be remedied using the following **“Troubleshooting plan (7.2)”** please contact the manufacturer.

In the event of faults in the function or operating behaviour of the valve, check whether the installation work was carried out and completed as described in this operating manual.

Depending on the field of application, the operation safety order must be observed.

Check the data on material, pressure, temperature, voltage and flow direction with the layout plan of the pipework system. In addition, check whether the operating conditions correspond to the technical data in the data sheet or on the rating plate.

7.2 Troubleshooting plan

Malfunction	Possible causes	Remedy
No flow	Pneumatic drive does not open	Switch off control valve (805) Clean sound absorber (600)
	Flange covers were not removed	Remove flange covers
Low flow rate	Obstruction in the pipe system	Check pipe system
Valve leaking at seat, no internal tightness	Valve disc sealing (400) damaged by external particles	See section 8 or replace valve
No external tightness	Gaskets damaged	See section 8 or replace valve
Valve closes too slowly	Ventilation boring in spring cap (112) closed	Open boring
	Control pressure too low	Check control pressure
	Reduced conductor cross sections	Replace folded control lines
Valve opens too slowly	Dirt in control line	Clean sound absorber (600) Clean vent line
		Valve does not close
Valve does not close	Dirt in control line	If necessary, clean filter in control line
	Reduced conductor cross sections	Replace folded control lines
	Flange fracture (valve/pipework)	Screws not tightened uniformly, mating flanges not aligned



NOTICE!

Observe section 9.0 before all installation and repair work

Observe section 6.4 when putting the valve back into operation!

8.0 Dismantling of the Valve

In addition to the general installation guidelines and the operation safety order, the following points must also be observed:



DANGER!

- Depressurised pipework system
- Cooled medium
- Emptied installation
- Vent pipework systems containing corrosive, inflammable, aggressive or toxic media
- Have dismantling work carried out only by qualified staff (see point 2.3)

8.1 Replacement of wear parts

Shut down the valve as described in section 6.2.

Switch off control valve (800) and disassemble the control line from pneumatic drive.

Instructions for Fig. 1, 2 and Fig. 3

Fig. 3 De-installation of limit switch addition.

Switch limit (803) switch to neutral. Open limit switch housing (120). Loosen and remove set screw (941) with switch actuator (513) from limit switch spindle (243). Loosen and remove spindle guide (212/4). Remove limit switch housing (120) with washer (906) from spring cap (112).



DANGER!

Opening of pneumatic drive.

Spring cap is under spring tension. At least two studs (236) must remain screwed to the spring cap.

Remove two opposing studs (236), or respectively, hexagon head screws (900/2) and replace them by threaded rods with nuts.

Drive size	KA70	KA120	KA 160	KA200	KA250
Threaded rod	M6 x 250	M10 x 450	M12 x 450	M16 x 500	M20 x 750

Manually tighten the threaded rods with nuts and loosen and remove the remaining studs (236)



NOTICE!

First, the spring cap (112) is pressed against the nuts of the threaded rod.

Loosen the nuts of the threaded rods so that the load on the pressure spring (503) is released. Remove threaded rods and spring cap (112). Disassemble spring guide (204), pressure springs (503) and pneumatic cylinder (111). Loosen nut (901/x). Remove spring disc (216), drive piston (217) and sealing piece (226).

Loosen hex. socket screw (910). Pull off spacer (110) and spindle guide (212/x) via the valve spindle (205).

Fig. 1 Flange version up to DN 100

Loosen hex. head screws (900). Pull housing flange (108), with valve spindle (205) and valve disc (200) completely out of the valve housing (100).

Fig. 2 Flange version from DN 125 onwards

Loosen hex. head screws (900). Pull housing flange (108), with valve spindle (205) and valve disc (200) completely out of the valve housing (100).

Before demounting the valve spindle (205) loosen setscrew (941/1). The valve spindle (205) is de-installed by loosening the spindle nut (219).



NOTICE!

Two-piece ring (218) falls out.

Fig. 3 Flange version 63-4-EPVO...N-4R

Loosen and remove hex. head screw (900) with lock washer (905/1). Remove housing flange (108) with spindle guide (212/1) out of valve chamber (100). Pull valve spindle (205) and valve disk (200*) complete out of valve chamber (100).



NOTICE!

Spare part kit includes a complete valve disk (200*) resp. spindle guide (212#). The position numbers marked with a (* or #) are supplied as complete unit.

Fig. 4 Thread version 10-4-EPVO...-4R..

Loosen and remove housing nut (101). Completely pull valve spindle (205) with valve disc (200) out of the valve housing (100).



NOTICE!

Spare part kit includes a complete valve disk (200*) resp. spindle guide (212*). The position numbers marked with a (* or #) are supplied as complete unit.

Assemble the valve in the reverse order to the dismantling.

Grease the valve spindle (205) in the sector of the lip-rings (404) and in the area of the two-piece ring (218) with lubricant Staburags N32 or equivalent material (DVGW-authorization).

Grease the pneumatic cylinder (111) in the sector of the drive piston (217) with lubricant Staburags NBU 30.



CAUTION!

Install sealing elements carefully and properly and do not damage them during assembly.

Examine the valve for internal and external leaks in accordance with DIN 3394-1, DIN EN 16678 and finally carry out a function test.

9.0 Warranty

Scope and period of the warranty is specified in the edition of the "General Terms of Business of the UNI-Geräte E. Mangelmann Elektrotechnische Fabrik GmbH" valid at the time of delivery or else in the purchase agreement.

We warranty that the valve is free from faults in line with the state of the art and for the confirmed field of application.

No warranty claims will be accepted for damage resulting from improper use or failure to observe these operating and installation instructions, the statutory accident prevention regulations, the EN, DIN and VDE standards and other codes and regulations.

Warranty claims will also not be accepted for damage occurring during operation due to operating conditions deviating from those specified in the data sheet or in other agreements.

Justified complaints will be remedied by reworking by us or specialist companies authorized by us.

Claims going beyond the scope of the warranty will not be accepted. The customer shall have no right to the supply of a replacement valve.

Maintenance work, installation of parts from other manufacturers, any modifications to the design and natural wear are not covered by the warranty.

Transport damage must be reported not to us but **without delay** to your responsible goods handling company, the railway company or the shipping agent as otherwise all claims for damages against these companies will be voided.

10.0 Explanation on Codes and Directives

The Commission of the European Union has laid down common directives for the free trading of goods within the Union specifying minimum requirements for safety and health protection. The CE symbol confirms that products comply with the EU directives, i.e. in conformity with the relevant, in particular harmonised standards. Regulation EU2016/426 and Directive 2014/68/EU are of relevance for the gas pneumatic valve (mechanical part).

Notes on Regulation EU2016/426 (Gas Appliances Regulation GAR):

The valves have been developed, manufactured and tested in accordance with harmonised standard DIN EN 16678 and DIN EN 16304 and comply with the relevant requirements of the Union Regulation EU2016/426. Unless otherwise stated separately, this has been confirmed by a type test.

Notes on Directive 2014/68/EU (Pressure Equipment Directive, DGRL):

It has been confirmed that the quality assurance in design control, manufacture and final acceptance of the manufacturer, UNI-Geräte E. Mangelmann Elektrotechnische Fabrik GmbH, satisfy the requirements of 2014/68/EU Article 14 Module H. The gas pneumatic valves comply with the fundamental requirements of Directive 2014/68/EU. Valves in according to Article 1 Paragraph 2,f,v or Article 4 paragraph 3 are not allowed to have the CE mark in according to Article 18.

Note concerning ex-guideline 2014/34/EU (explosion guideline ATEX):

The product is not subject to guideline 2014/34/EU, since due to the loads occurring during practical operation, there is no effective source of ignition even in case of an error case to be assumed. This also applies to spring loaded components in gas-filled rooms. In case of electric drives, sensors or other electric components the application as per 2014/34/EU is to be checked separately.

11.0 Sectional Drawing

11.1 Fig. 1 Flange design 1/3/5/6/10-4 EPV(O)...N(H)R...

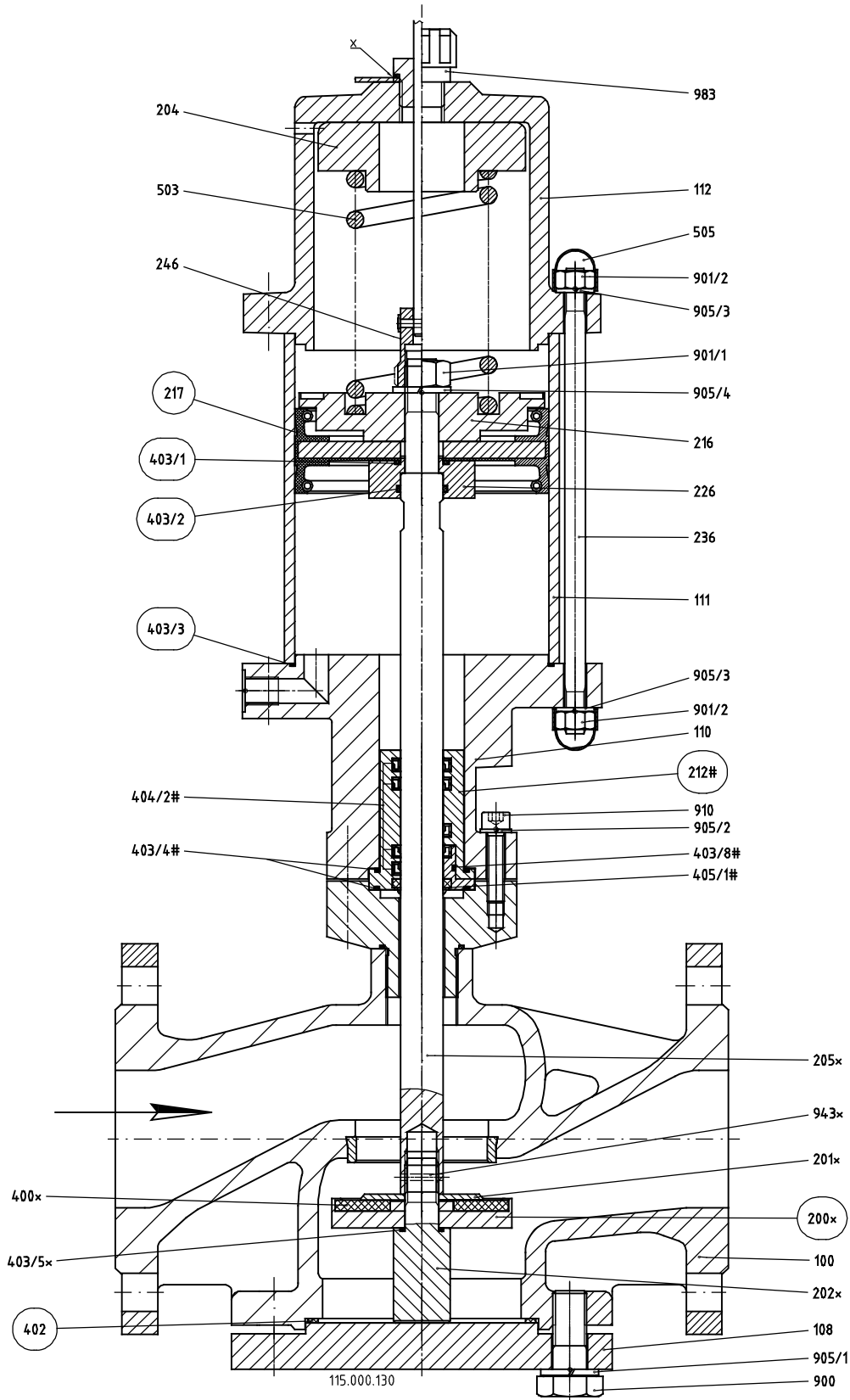

 = Spare part kit

X = Option limit switch mounting

Fig. 2 Valve disc from DN 125 Flange design

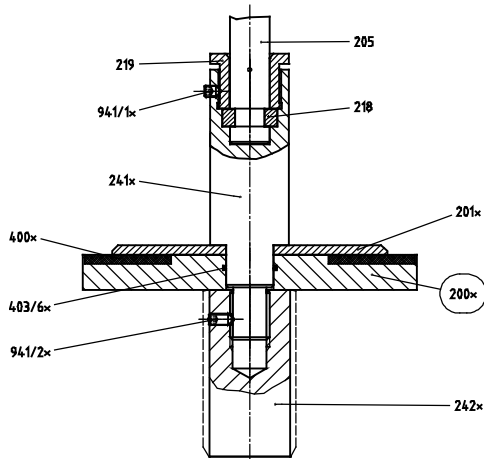
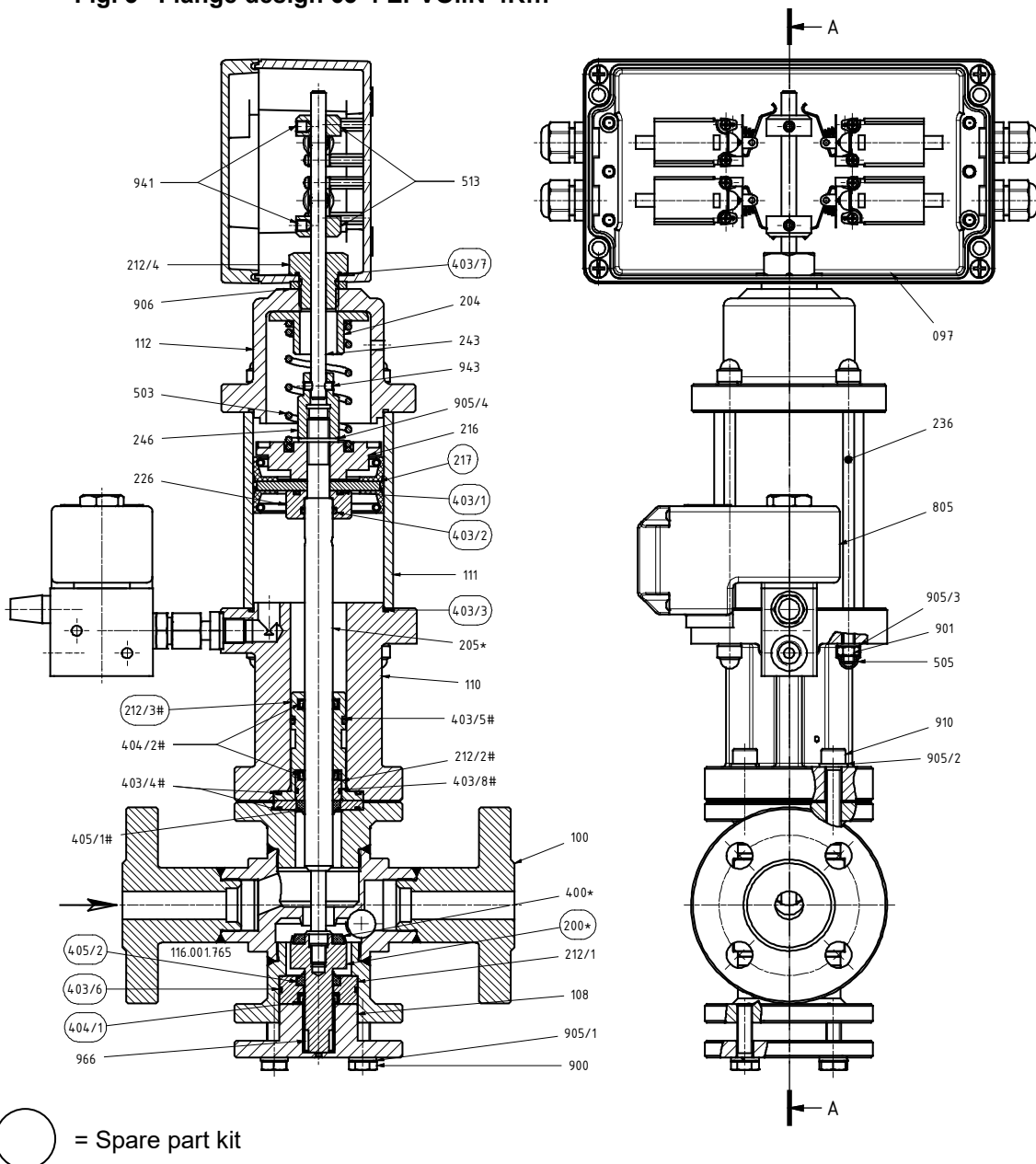
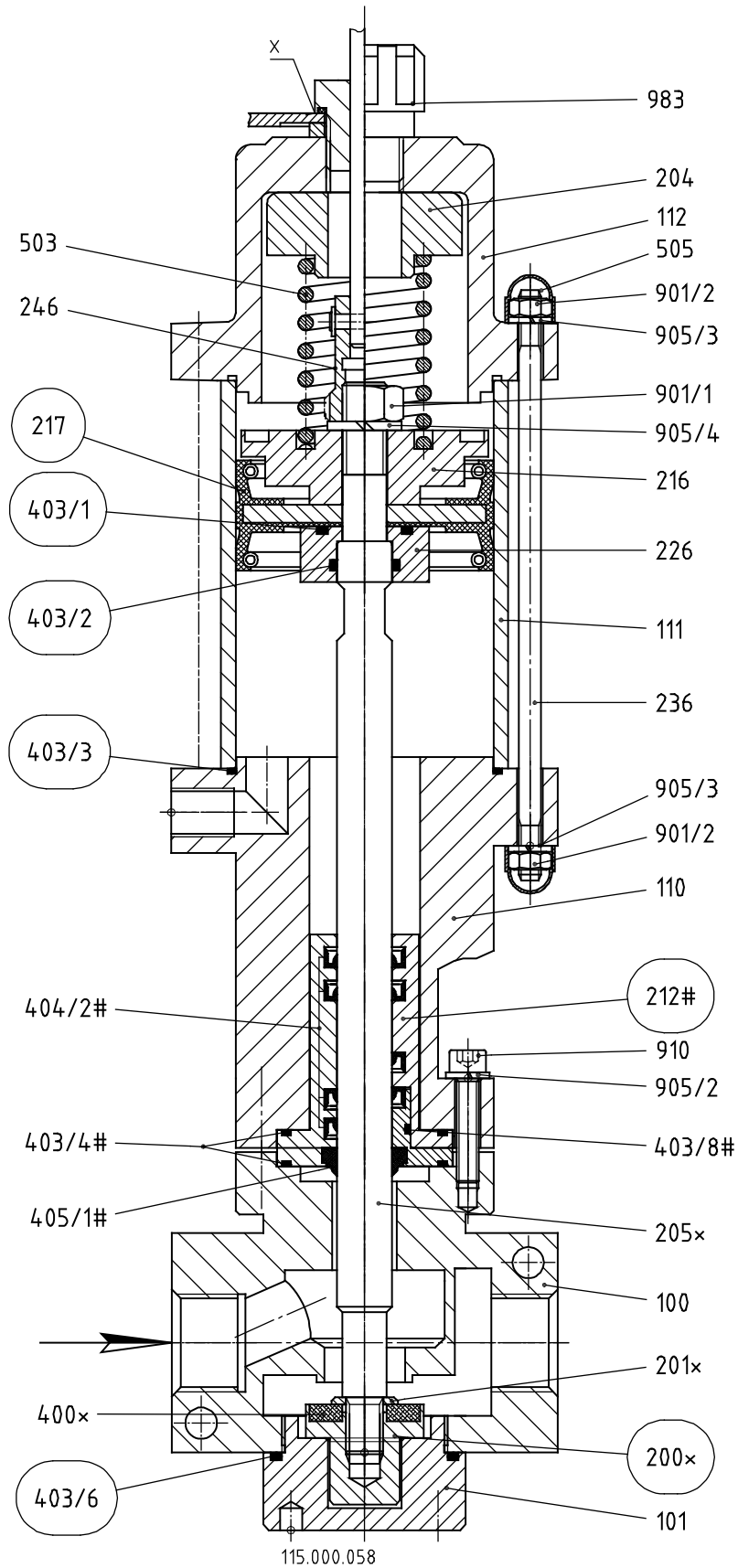

Fig. 3 Flange design 63-4 EPVO..N-4R...



○ = Spare part kit

Fig. 4 Thread design 10-4-EPVO...-4R



 = Spare part kit

X = Option limit switch mounting

11.2 Projection
Flange design
Fig. 1 1-10-4-EPV(O)..N(H)R..

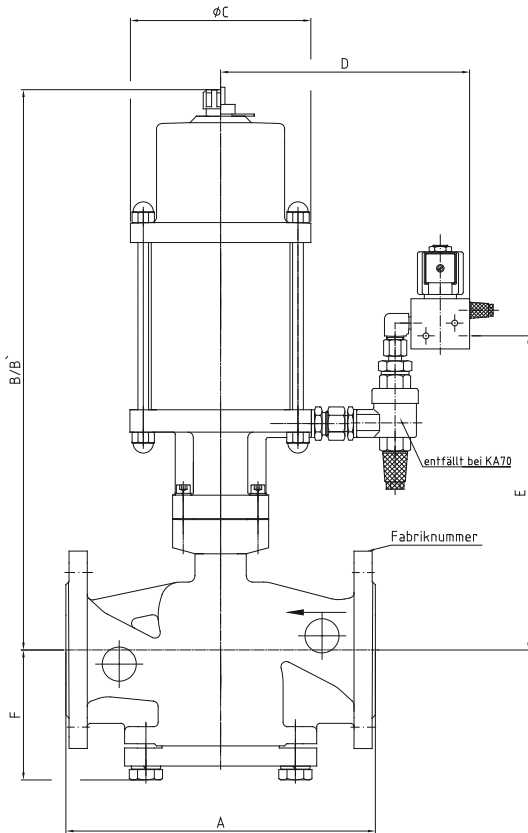
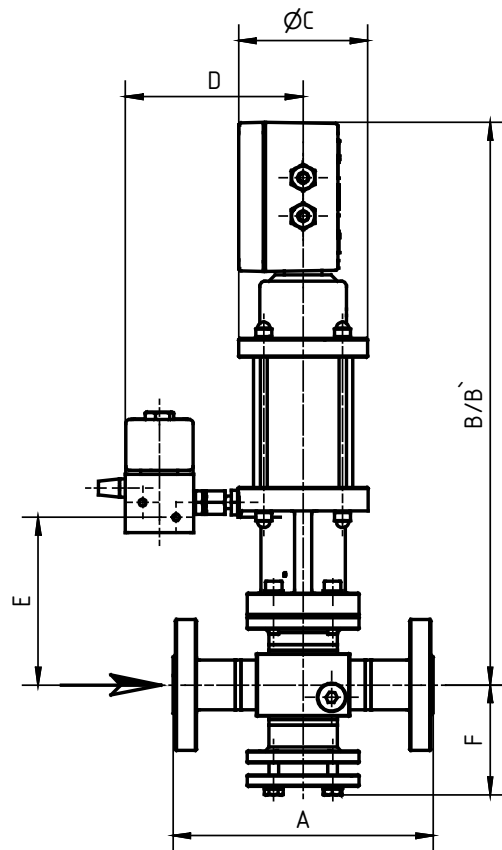
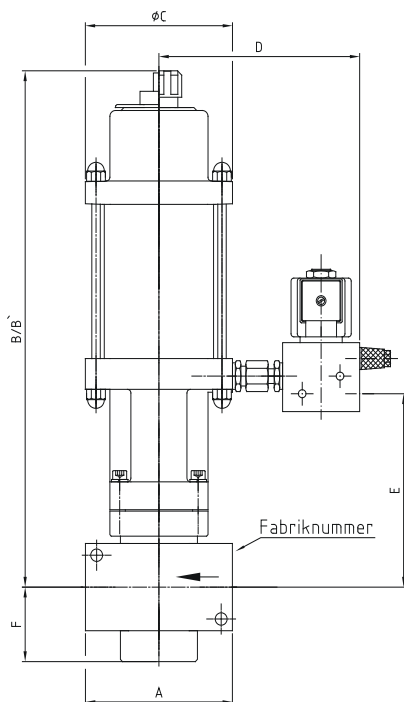

Fig. 3 63-4-EPVO..N-4R...



Threaded design
Fig. 4 10-4-EPVO 7-4R..



B' = Dimension for removing the spring cap.

11.3 Control valve

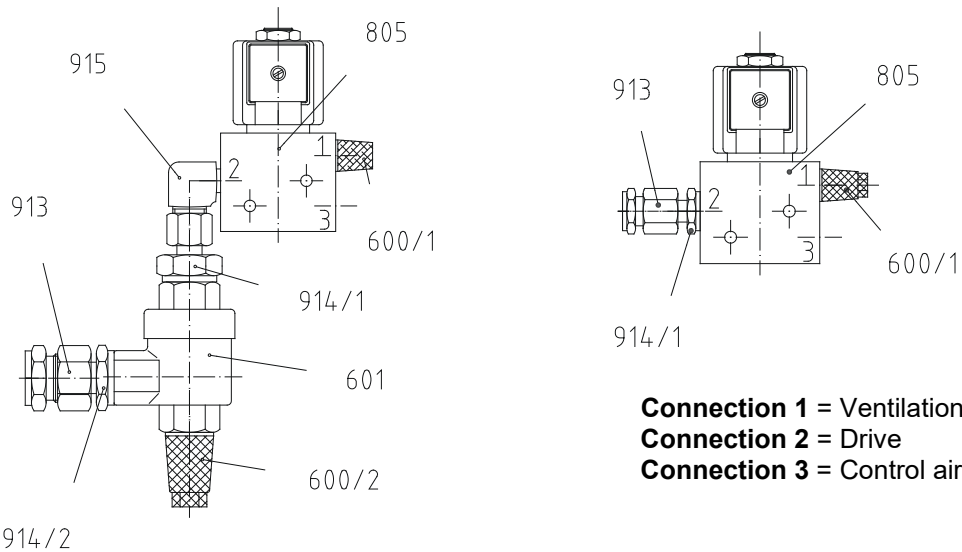

11.4 List of parts

Pos./ Item	Stück/ Qty.	Benennung	Description
097	1	Endschalteranbau	Limit switch mounting
100	1	Ventilgehäuse	Valve chamber/ housing
101	1	Gehäusemutter	Housing nut
108	1	Gehäuseflansch	Housing flange
110	1	Distanzstück	Spacer
111	1	Pneumatikzylinder	Pneumatic cylinder
112	1	Federdom	Spring cap
200	1	Ventilteller	Valve disk
201	1	Tellerscheibe	Disk plate
202	1	Ventilstück	Valve piece
204	1	Federführung	Spring guide
205	1	Ventilspindel	Valve spindle
212	1	Spindelführung	Spindle guide
212/1	1	Spindelführung	Spindle guide
212/2	1	Spindelführung	Spindle guide
212/3	1	Spindelführung	Spindle guide
212/4	1	Spindelführung	Spindle guide
216	1	Federteller	Spring disk
217	1	Antriebskolben	Drive piston
218	1	Zweiteiliger Ring	Two-piece ring
219	1	Spindelmutter	Spindle nut
226	1	Dichtstück	Sealing piece
236	4	Stiftschraube	Stud
241	1	Ventiltelleraufhängung	Valve disk mounting
242	1	Telleranschlag	Plate notice
243	1	Endschalterspindel	Limit switch spindle
400	1	Ventiltellerdichtung	Valve disc sealing
402	1	Flachdichtung	Flat gasket
403/1	1	O-Ring	O-ring
403/2	1	O-Ring	O-ring
403/3	1	O-Ring	O-ring
403/4	2	O-Ring	O-ring
403/5	1	O-Ring	O-ring
403/6	1	O-Ring	O-ring
403/7	1	O-Ring	O-ring

Pos./ Item	Stück/ Qty.	Benennung	Description
403/8	1	O-Ring (nur bei buntmetallfreier Ausführung)	O-ring (only non-ferrous free metal type)
404/1	1	Lippenring	Lip-ring
404/2	2/4	Lippenring	Lip-ring
405/1	1	Abstreifring	Scraper ring
405/2	1	Abstreifring	Scraper ring
503	1	Druckfeder	Pressure spring
505	8	Schutzkappe	Protective cap
513	2	Endschalterbetätigung	Switch actuator
600/1	1	Schalldämpfer	Sound absorber
600/2	1	Schalldämpfer	Sound absorber
601	1	Schnellentlüfter	Quick-venting mechanism
805	1	Steuerventil	Control valve
900	4/6	Sechskantschraube	Hex. head screw
901/1	1	Sechskantmutter	Hex. nut
901/2	8	Sechskantmutter	Hex. nut
905/1	4/6	Federring	Lock washer
905/2	4	Federring	Lock washer
905/3	8	Federring	Lock washer
905/4	1	Federring	Lock washer
910	4	Zylinderschraube	Cylinder screw
913	1	Gerade Einschraubverschraubung	Linear threaded screw connection
914/1	1	Gerader Aufsteckstutzen	Linear put on adapter
914/2	1	Gerader Aufsteckstutzen	Linear put on adapter
915	1	Winkel-Einschraubverschraubung	Angle threaded screw connection
941/x	1	Gewindestift	Setscrew
943	1	Spannstift	Spring dowel sleeve
966	1	DU- Buchse	DU-liner
983	1	Entlüftungsstopfen	Exhaust plug

²⁾ Is void KA 70

Spare parts

Version	Fig.	Type	Spare part
Flange version	Fig. 1	1 to 10-4-EPVO..N(H)R.. DN15 – DN150	Spare part kit
	Fig. 3	63-4-EPVO..N-4R.. DN15, DN20	Spare part kit
Thread version	Fig. 2	10-4-EPVO 7-4R...	Spare part kit

Dimension Flange design

Series	DN	A ¹⁾ A [*]	ANSI	B	B`	ØC	D	E	F
1-4-EPV(O)..NHR..	80	310	3"	420	620	105	150	225	145
	150	480	6"	600	870	170	230	350	220
3-4-EPV(O)..NHR..	40	200	1 1/2"	390	550	105	150	175	110
	100	350	4"	570	830	170	230	320	155
5-4-EPV(O)..NHR..	80	310	3"	540	800	170	230	290	145
6-4-EPV(O)..NHR..	65	290	2 1/2"	520	770	170	230	270	125
10-4-EPVO..N(H)-4R..	15	130	1/2"	355	515	105	150	165	82
	20	150	3/4"	355	515	105	150	165	82
	25	160	1"	360	520	105	150	165	90
	40	200	1 1/2"	480	730	170	230	250	110
	50	230	2"	490	740	170	230	260	115
	65	290	2 1/2"	525	780	170	230	300	125
63-4-EPVO...N-4R..	15	210	1/2"	354	514	105	144	135	89
	20	230	3/4"	354	514	105	144	135	89

Dimension Thread design

Series	G	A	B	B`	ØC	D	E	F
10-4-EPVO..-4R..	3/4	105	320	480	105	150	135	60

A¹⁾ = Dimension at DIN (resp. flanges ANSI and dimension DIN or flanges and dimension at DIN)

A^{*} = Dimension at ANSI 150lbs (see data sheet on our website armature installation length
225 100 026)

B` = Dimension for disassembling of complete drive

12.0 Declaration of Conformity

UNI-Geräte E. Mangelmann
Elektrotechnische Fabrik GmbH
Holtumsweg 13
D – 47652 Weeze



EU

Konformitätserklärung Declaration of Conformity

Produkt / Product	Automatisches Absperrventil - stromlos offen / Automatic shut off valve - current less open		
Handelsbezeichnung / Trade Mark	Pneumatikventil / Pneumatic valve		
Baureihe / Series	...EPVO...		
Nennweiten / Size	DN 15^{a)} / 20^{a)} / 25^{a)} / 32^{a);b)} / 40^{a);b)} / 50^{a);b)} / 65^{a);b)} / 80^{b)} / 100^{b)} / 125^{b)} / 150^{b)} / 200^{b)} / 250^{b)} / 300^{b)} / 350^{b)} / 400^{b)}		
Druckstufe / Pressure Stage	PN 10^{a);b)} / 16^{b)} / 25^{b)} / 40^{b)} / 63^{a);b)} / 100^{b)} / 160^{b)}		
Fluidgruppe / Fluid Group	Brennbare Gase, FL. Gr.1 / Flammable gases, FL. Gr.1		
EU - Richtlinien / EU - Directives	EU/2016/426^{a)} Gasgeräteverordnung / Gas Appliance Regulation 2014/68/EU^{b)} Druckgeräterichtlinie / Pressure Equipment Directive		
Konformitätsbewertungsverfahren / Conformity Assessment Procedure	Modul B + D - EU/2016/426^{a)}; Modul H - 2014/68/EU^{b)}		
Angewandte technische Spezifikation / Applied Technical Specification	^{a)}DIN EN 16678:2016-02; DIN EN 13611:2016-09; ^{b)}DIN EN 16668:2018-05; DIN EN 12266:2012-04		
Baumusterprüfung / Type Examination	CE-0085AS0513^{a)}	EU/2016/426	Modul B
	DVGW CERT GmbH Josef-Winter-Str. 1-3 D-53123 Bonn Zertifizierungsstelle / Notified Body 0085		
Überwachungsverfahren / Surveillance Procedure	SE-0085BL7038^{a)}	EU/2016/426	Modul D
	DVGW CERT GmbH Josef-Winter-Str. 1-3 D-53123 Bonn Zertifizierungsstelle / Notified Body 0085		
	CE-0062-PED-H-UGM 001-23-DEU^{b)}	2014/68/EU	Modul H
	Bureau Veritas Services SAS 8 Cours du Triangle 92800 PUTEAUX – LA DEFENSE Zertifizierungsstelle / Notified Body 0062		
Kennzeichnung / Marking	CE - 0085^{a)} oder/oder CE - 0085^{a)} oder/oder CE - 0062^{b)}		

Das Unternehmen UNI Geräte E. Mangelmann Elektrotechnische Fabrik GmbH erklärt in alleiniger Verantwortung, dass die o.a. Baureihe die grundsätzlichen Anforderungen der aufgeführten Richtlinien und Normen erfüllt.

UNI Geräte E. Mangelmann Elektrotechnische Fabrik GmbH confirms under the sole responsibility of the manufacturer, that the basic requirements of the above specified directives and standards are fulfilled.

Weeze, 24.01.2023

Ort und Datum / place and date

Geschäftsführer / Managing Director
Norbert Schneider

^{a); b)} Anwendung in Abhängigkeit von Nennweite und / oder Druckstufe: / Application depending on size and / or pressure stage:
DN ≤ 25 und / oder PS ≤ 0,5bar siehe Diagramm 6, oder Kat.1 + erfasst von EU/2016/426, fallen nicht in den Anwendungsbereich der 2014/68/EU.
DN ≤ 25 and / or PS ≤ 0,5bar see diagram 6, or Kat.1 + under the scope of EU/2016/426, are not covered by the scope of the EU-Directive 2014/68/EU.
250.100.005-04

UNI-Geräte E. Mangelmann
Elektrotechnische Fabrik GmbH
Holtumsweg 13
D – 47652 Weeze

UK Declaration of Conformity UK Konformitätserklärung

We / Wir:

UNI-Geräte E. Mangelmann
Elektronische Fabrik GMBH
Holtumsweg 13
D – 47652 Weeze

Declare that / Erklären hiermit:

Product / Produkt	Automatic vent valve – current less open <i>Automatisches Abblaseventil – stromlos geöffnet</i>
Trade Mark / Handelsbezeichnung	Pneumatic valve / Pneumatikventil
Series / Baureihe	...EPVO...
Size / Nennweiten	DN 15 / 20 / 25 / 50 / 65
Pressure Stage / Druckstufe	PN 10 / 63
Fluid Group / Fluidgruppe	Gas type of the 1st, 2nd and 3rd family gases <i>Gasart der 1., 2. und 3. Gasfamilie</i>

Satisfies the essential requirements of the Regulation 2016/426 on gas appliances as brought into UK law and amended and is manufactured in accordance with the UK designated standards:

Erfüllt die grundlegenden Anforderungen der Verordnung 2016/426 für Gasgeräte in der im Vereinigten Königreich geltenden und geänderten Fassung und wird in Übereinstimmung mit den im VK festgelegten Normen hergestellt:

Standards Numbers / Normen Nummern: BS EN 16304:2013, BS EN 16678:2015

BSI has performed the following conformity assessment procedures specified in the Regulation 2016/426 on gas appliances as brought into UK law and amended:

Das BSI hat die folgenden Konformitätsbewertungsverfahren durchgeführt, die in der Verordnung 2016/426 für Gasgeräte, wie sie in britisches Recht umgesetzt und geändert wurde, festgelegt sind:

Annex III Module B (Type Examination) and issued the Certificates below:

UKCA Module B certificate: (Certificate No.) UKCA 772968

Anhang III Modul B (Baumusterprüfung) geprüft und die nachstehenden Bescheinigungen ausgestellt:

UKCA-Modul-B-Zertifikat: (Zertifikats-Nr.) UKCA 772968

Annex III Module D (Conformity to Type based on Quality Assurance of the Production Process) and issued the Certificates below:

UKCA Module D certificate: (Certificate No.) UKCA 772905

Anhang III Modul D (Konformität mit der Bauart auf der Grundlage der Qualitätssicherung des Produktionsprozesses) und stellte die nachstehenden Zertifikate aus:

UKCA-Modul-D-Zertifikat: (Zertifikats-Nr.) UKCA 772905

Approved Body / Zugelassene Stelle:

BSI Assurance UK Limited (Approved Body No. 0086)

Address / Adresse:

**Kitemark Court, Davy Avenue,
Knowlhill Milton Keynes MK5 8PP UK.**

This declaration of conformity is issued under the sole responsibility of the manufacturer.

Diese Konformitätserklärung wird unter der alleinigen Verantwortung des Herstellers ausgestellt.

Name / Name:

Norbert Schneider

Title / Position / Funktion:

Dipl. Ing. / Managing Director / Geschäftsführer

Place & date of issue /

D – 47652 Weeze, 22.02.2023

Ort und Datum der Ausstellung:

Signature / Unterschrift:

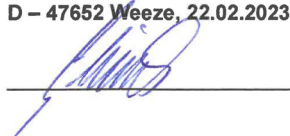

250.100.578-00