

Operating and mounting manual flow control butterfly valves MRK Ro MA...(R)

Contents

1.0 General Remarks

- 1.1 Butterfly data
- 1.2 Application

2.0 Danger Notices

- 2.1 Safety terms
- 2.2 Safety notice
- 2.3 Qualified staff
- 2.4 Unauthorized modification and spare part production
- 2.5 Unauthorized operation
- 2.6 Safety information for the use in explosion-prone areas guideline 2014/34/EU

3.0 Handling

- 3.1 Transport
- 3.2 Storage
- 3.3 Handling before mounting

4.0 Product Description

- 4.1 Function
 - 4.1.1 NC normally close MRK Ro Ma
 - 4.1.2 NO normally open MRK Ro Ma...R
 - 4.1.3 Adjustment of the base (G) and main flow rates (M)
- 4.2 Technical data
- 4.3 Marking

5.0 Installation

- 5.1 Warning of dangers during installation, operation and maintenance
- 5.2 Installation

6.0 Operation

- 6.1 Commissioning
- 6.2 Shutting down
- 6.3 Maintenance
- 6.4 Putting back into operating

7.0 Troubleshooting

- 7.1 Detection of defects
- 7.2 Troubleshooting plan

8.0 Dismantling of the Flow Control Butterfly Valve

- 8.1 Replacement of wear parts

9.0 Warranty

10.0 Explanations on Codes and Directives

11.0 Drawing

- 11.1 Sectional drawing
- 11.2 List of parts

12.0 Declaration of Conformity

1.0 General Remarks

This operating manual includes instructions to assemble and operate the valve in the prescribed and safe way. **Additionally, the adequate operating instructions of each special solenoid drive must be considered.**

Series MG...	220.100.038
Series MG...X	220.100.040
Series MG...Xme	220.100.039

If any difficulties appear that can not be solved by means of the operation instructions, further information may be demanded from the manufacturer.

This operating manual is in accordance with the relevant valid EN safety standards and the valid prescriptions and rules of the Federal Republic of Germany.

If the flow control butterfly valve are used abroad of the FRG, the operator and/or the person who is responsible for the plant concept must take care that the valid national rules are met. The manufacturer reserves the right of any technical change and improvement.

The use of these operating instructions suppose the qualification of the user according to paragraph 2.3 "qualified staff".

The operating staff must be trained in accordance with the operating instructions. The operating manual must always be available at the location where used.

1.1 Butterfly data

Manufacturer:

UNI Geräte E. Mangelmann
Elektrotechnische Fabrik GmbH
Holtumsweg 13
D-47652 Weeze
Telefon: +49 (0) 2837/9134-0
Fax: +49 (0) 2837/1444
E-Mail: info@uni-geraete.de
Homepage: www.uni-geraete.de

Designation

Actuators for control without zero obturation

Control base: Design-checked as per EU/2016/426, Prod. ID. Nr. CE-0085-AR0408
DIN EN 16678
DINEN 161

Type:	Working pressure	Ambient temperature	Medium	Medium-temperature
MRK Ro Ma	0 – 150mbar	-20°C to +60°C	Gases 1 st , 2 nd and 3 rd gas families and air	-20°C to +60°C
MRK Ma..Ü200	0 – 150mbar	-20°C to +60°C	Hot air / for neutral gases	-20°C to +200°C
MRK Ma..Ü550	0 – 150mbar	-20°C to +60°C	Waste gas / Hot air	up to 550°C
MRK Ma..Ü700	0 – 150mbar	-20°C to +60°C	Waste gas / Hot air	up to 700°C
MRK Ma..Ü700	0 – 150mbar	-20°C to +60°C	Waste gas	up to 1000°C

Design: Butterfly plate through passage
Butterfly plate limit stop
Special control butterfly plate
In case of construction with striking butterfly a "-2" is added to the model designation e.g. MRK Ro Ma ...N-4-2

Fitting position: Horizontal pipe standing drive $\pm 5^\circ$; with additional order information "W"
vertical pipe standing drive $\pm 5^\circ$.

Switching cycles: see operating instructions (BTA) solenoid drive

Installation between two flanges as per DIN EN 1092-2 / ANSI

Type	Prod. ID. Nr.	15 (5N)	20 (7N)	25 (10N)	32 (12N)	40 (15N)	50 (20N)	65 (25N)	80 (30N)
MRK Ro Ma	CE-0085-AR0408	X	X	X	X	X	X	X	X
MRK Ma..Ü200	-	X	X	X	X	X	X	X	X
MRK Ma..Ü550	-	X	X	X	X	X	X	X	X
MRK Ma..Ü700	-	X	X	X	X	X	X	X	X
MRK Ma..Ü1000	-	X	X	X	X	X	X	X	X

Type	Prod. ID. Nr.	100	125	150	200	250	300	350	400
MRK Ro Ma	CE-0085-AR0408	X	X	X	X	X	X	X	X
MRK Ma..Ü200	-	X	X	X	X	X	X	X	X
MRK Ma..Ü550	-	X	X	X	X	X	X	X	X
MRK Ma..Ü700	-	X	X	X	X	X	X	X	X
MRK Ma..Ü1000	-	X	X	X	(*)	(*)	(*)	(*)	(*)

(*) DN200 to DN 400 on request

Voltage: VDC 12 – 440 (–15% bis +10%)
VAC 24 – 500 (–15% bis +10%)

Protection type: IP54 or IP65

Frequency 40 – 60 Hz

Power 10 – 4000W

Details to the electrical data can be found on the type sign and the adequate operating instructions of the solenoid valves.

1.2 Application

The UNI-Geräte flow control butterfly valves MRK (Ro) Ma are used as control appliances for control tasks all over fuel engineering.

The flow control butterfly valve are suitable for gases of the 1st, 2nd and 3rd gas families to G260 and for neutral gases and air. As a variant with material design for hot air, waste gases and aggressive gases such as e.g. biogas, sewage plant gas or dump gas to G262.

If used in other cases, the operator must carefully check if construction/design of flow control butterfly valve, accessories and materials are suitable for the new application. The range of application is subject to the responsibility of the plant planner. The service life of the flow control butterfly valve is 20 years.

2.0 Danger Notices

2.1 Safety terms

The signal terms DANGER, CAUTION und NOTICE are used in this operating manual in case of notices concerning special dangers, or for unusual information requiring a special marking.



DANGER! means that in case of non-observance there is danger to life and/or considerable damage.



CAUTION! means that in case of non-observance there is danger of injury and/or damage.



NOTICE! means that attention is drawn to technical correlations/connections.

Observance of other, not especially marked notices concerning transport, assembly, operation and maintenance and other data (in the operating manual, product documentation and at the unit itself) is also essential, in order to avoid disturbances that might affect direct or indirect damage to property or injury to persons.

2.2 Safety notice

Non observance of safety instructions can lead to loss of any claim for damages.

Non observance can lead to the following mentioned dangers:

- Failure of important functions of the flow control butterfly valve/plant
- Endangering of persons by electrical or mechanical influences.
- Protection against accidental contact for moving parts may not be removed as long as the flow control butterfly valve is in operation.
- Leakage of dangerous media (e.g. explosive, toxic, hot) must be removed in the way that there is no danger for persons or environment. Laws and regulations must be observed.

2.3 Qualified staff

These are persons who are familiar with erection, assembly, starting, operation and maintenance of the product and who have special qualifications acc. to their activities and functions, e.g.:

- Instruction and obligation to carry out and meet all regional and in-house orders and requirements.
- Education or instruction according to the safety engineering standards in use and maintenance of adequate safety and working protection equipment.
- Training in first aid.

2.4 Unauthorized modification and spare part production

Modification or changes of the flow control butterfly valve are only allowed after agreement of the manufacturer. Original drawings and accessories authorized by the manufacturer are for safety purposes. The use of other parts or unauthorized changes at the flow control butterfly valve by third persons may cancel and abolish the manufacturer's liability for resulting consequences.

2.5 Unauthorized operation

Operational reliability of the delivered flow control butterfly valve is only guaranteed in case of determined use in accordance to paragraph 1 of the operating manual. **The application limits mentioned on the type sign may on no account be exceeded.**

2.6 Safety information for the use in explosion-prone areas guideline 2014/34/EU

- The temperature of the medium must not exceed the respective temperature class, and respectively, the respective maximum permitted medium temperature as per operation guidelines.
- If the valve is heated (e.g. heating jacket), care must be taken, that the specified temperature class is kept in the line.
- The valve must be connected to the ground.
In the case most simple this can be realized via pipe screws by means of tooth discs.
Otherwise the connection to the ground must be implemented by other measures e.g. cable links.
- Control valves, electrical and electrical/mechanical drives as well as sensors must undergo a separate conformity check as per ATEX. In doing so the respective safety and explosion protection information in the operation instructions are to taken into special consideration.
- Any modifications whatsoever to the valve are not allowed. The ATEX approval is void with immediate effect if the valve is modified without prior authorisation (even including painting).
- UNI-Geräte GmbH must be consulted before any modifications are made.

Furthermore we point out the guideline ATEX 118a, which include the minimum regulations for the improvement of the health-related situation and the safety of the employees, who might be jeopardized by an explosive atmosphere.

3.0 Handling

3.1 Transport

For any transport works, the generally recognised technical rules and standards as well as rules for prevention of accidents must be observed.

The goods to be transported must be carefully treated. During transport, the flow control butterfly valve must be protected against strokes, impacts or vibration. The coat of lacquer may not be damaged. Transport temperature is -20°C up to $+60^{\circ}\text{C}$.

Never transport the flow control butterfly valve at screwed cable glands, appliance plugs or add-on units. The flow control butterfly valve is to be transported with a belt below the solenoid drive.

Transport the flow control butterfly valve in a case or on a pallet with smooth base and put it softly on plain floor.

The goods must be checked on completeness and transport damage. See also section 9.0

3.2 Storage

If the flow control butterfly valve is not installed immediately after delivery, it must be stored properly.

- Storage of the flow control butterfly valve with an opening of approximately 15°.
- Storage temperature -20°C up to +60°C, dry and clean.
- The lacquering protects against corrosion in neutral dry atmosphere. Do not damage colour.
- In humid rooms, a drying agent or a heating resp. is necessary because of condensation of water.

Requirements according to DIN 7716 (products made of caoutchouc and rubber) must be met.

3.3 Handling before mounting

- In case of valve with protection caps, they must be removed before being mounted!
- Protect against atmospheric influences such as humidity.
- Appropriate treatment protects against damage.

4.0 Product Description

The UNI-Geräte MRK (Ro) Ma (R), (MRK Ma..Ü(R)) are control appliances for control without zero adjustment with (without) EG design control certificate and product ID-no. as per gas appliances regulation EU/2016/426.

The section drawings in section 11.1, fig. 1, 2, 3 and 4 show the design of the flow control butterfly valve.

4.1 Function

- NC normally close MRK (Ro) Ma
- NO normally open MRK (Ro) Ma..R

4.1.1 Function NC normally close MRK (Ro) Ma...

By switching on of the solenoid drive (800) the magnet core (207) is drawn and operates the butterfly plate (232) via the toothed rack (247) and the toothed spindle (248) releasing the set cross section. The flow control butterfly valve is open and moves the butterfly plate (232) into the main setting.

In case of switching off, breakdown or interruption of the energy supply to the solenoid drive, the solenoid core (207) withdraws due to the pre-stress of the pressure spring (503) and closes the flow control butterfly valve, and respectively, re-moves the butterfly plate (232) into the basic position.

4.1.2 Function NO normally open MRK (Ro) Ma..R..

By switching on of the solenoid drive (800) the magnet core (207) is drawn and operates the butterfly plate (232) via the toothed rack (247) and the toothed spindle (248) releasing the set cross section. The flow control butterfly valve is closed, and respectively, removes the butterfly plate (232) into the basic position.

In case of switching off, breakdown or interruption of the energy supply to the solenoid drive, the solenoid core (207) withdraws due to the pre-stress of the pressure spring (503) and opens the flow control butterfly valve or re-moves the butterfly plate (232) into the main setting.

4.1.3 Adjustment of the base (G) and main flow rates (M)

The base and main rates are not preset at the factory, in the normal condition, the volume control butterfly valve is NC normally close MRK Ro Ma (NO normally open MRK Ro Ma..R).

1. Unscrew the protective cap (505).
2. Loosen the hex. nuts (901/1) resp. (901/3).

3. By turning to the right the adjusting pin (954/1) base flow rates resp. (954/2) for main flow rates, the desired value may be set.
4. After the adjustment, lock the adjusting pin (954/1) resp. (954/2) by retightening the hexagonal nuts,(901/1) resp. (901/3).
5. Reinstall the threaded protective cap (505).

4.2 Technical data

Solenoid –drive types MG...

Type	DN							
	15 (5N)	20 (7N)	25 (10N)	32 (12N)	40 (15N)	50 (20N)	65 (25N)	80 (30N)
MRK Ro Ma (R)	012	012	012	012	012	012	012	012
MRK Ma Ü200(R)	012	012	012	012	012	012	012	012
MRK Ma Ü550(R)	012	012	012	012	012	014	014	014
MRK Ma Ü700(R)	016	016	016	016	018	018	018	018
MRK Ma Ü1000(R)	016	016	016	016	018	018	018	018

Type	DN							
	100	125	150	200	250	300	350	400
MRK Ro Ma (R)	012	012	014	016	019	019	019	020
MRK Ma Ü200(R)	012	012	014	016	019	019	019	020
MRK Ma Ü550(R)	014	014	016	019	019	019	019	020A1
MRK Ma Ü700(R)	019	019	019	020	020	020	020A1	020A2
MRK Ma Ü1000(R)	019	019	019	-	-	-	-	-

Drive types with "A" consist of pickup and holding winding

Starting torque, pipe screws greased

DN	8	10	15	20	25	32	40	50	65	80	100	125	150
Torque Nm	20	30	30	30	30	50	50	50	50	50	80	160	160

Starting torque, product screws and nuts greased

Screw	M6	M8	M10	M12	M16	M20	M24
Torque Nm	5	11	22	39	70	110	150

4.3 Marking

The type sign on the solenoid drive has the following information:

- Fabricator
- Valve type, nominal width, pressure and temperature indication, fitting position
- Year of construction/ production no.
- Product ID No. to EU/2016/426
- Valve class and valve group acc. to DIN EN 16678, DIN EN 161
- CE-sign and no. of relevant location to 2014/68/EU
- Fluid group and test pressure PT to 2014/68/EU
- Solenoid drive type
- Voltage
- Frequency
- Protection type

When using solenoid drives for ex-protection zone 1 refer to information in the valid operating instructions. Main and basic volume in case of EEx solenoid drive see fig. 5.

Refer also to section 10.0.

5.0 Installation

5.1 Warning of dangers during installation, operation and maintenance



DANGER!

Safe operation of the flow control butterfly valve can only be guaranteed if it is installed, commissioned and maintained by qualified personnel (see point 2.3 “Qualified staff”) correctly and in observance of the warnings in this operating manual. Apart from that, the operation safety order and the qualified use of tools and protection equipment must be guaranteed. The operating instructions for the flow control butterfly valve must be observed during all work on or with the flow control butterfly valve. Failure to observe these instructions may result in injury or in damage to the flow control butterfly valve or other installations.

When the valve is used as a final sealing element, a safety precaution e.g. blanking disc, blind flange, etc., in accordance with the code of practice of the German Technical and Scientific Association for Gas and Water (DVGW) is recommended during all repair work.

5.2 Installation

Apart from the general installation guidelines, the following points should be observed:



NOTICE!

- The inside of the valve and the pipeline must be free from foreign particles.
- Observe the installation position in relation to the flow direction, see markings on the valve.
- Centre gaskets between the flanges.
- The connecting flanges must be aligned.
- Ensure that none of the components is strained during installation.
- The flow control butterfly valve must not be used as a fixed point; it is supported by the pipework system.
- Protect flow control butterfly valves from soiling, particularly during construction work.
- Thermal expansion of the pipework must be equalized using compensators.

The flow control butterfly valve can be installed with a standing-up, however, not with a hanging solenoid drive. With additional order information "W" in the type designation the flow control butterfly valve can be installed into a vertical pipe with standing-up solenoid drive.



NOTICE!

Please observe the solenoid drive operating instructions (BTA).

6.0 Operation



DANGER!

Before commissioning a new installation or before starting up an installation again after repairs or modifications, ensure:

- The proper completion of all installation and assembly work!
- Commissioning only by “qualified staff” (see point 2.3).
- Installation or repair of existing guards and protection equipment.

6.1 Commissioning

- Before commissioning, check the data on material, pressure, temperature and flow direction with the layout plan of the pipework system.
- Depending on the field of application, the local regulations have to be observed, e.g. the operation safety order.
- Residues in the pipework and the valve (dirt, weld beads, etc.) will inevitably result in leaks.
- Leakage inspection of the installed flow control butterfly valve.

6.2 Shutting down

- Depending on the field of application, the local regulations have to be observed, e.g. the operation safety order.

6.3 Maintenance

Flow control butterfly valves have to be checked at regular intervals for proper function and internal leak tightness. The intervals for regular inspections have to be defined by the operator according to the operating conditions. UNI-Geräte recommends an internal visual inspection once a year and an overhaul of the flow control butterfly valve after 2 years or after the following number of switching cycles at the latest:

Application temperature	DN ≤ 25	≤ DN 80	≤ DN 150	> DN 150
≤ 25°C	150 000	75 000	25 000	20 000
> 25°C	50 000	25 000	25 000	5 000

6.4 Putting back into operation

When putting a flow control butterfly valve back into operation, ensure that all the necessary steps described in section 5.2 (Installation) and section 6.1 (Commissioning) are repeated.

7.0 Troubleshooting

7.1 Detection of defects



DANGER!

Be sure to observe the safety instructions during troubleshooting.

If the malfunctions cannot be remedied using the following **“Troubleshooting plan (7.2)”** please contact the manufacturer.

In the event of faults in the function or operating behaviour of the valve, check whether the installation work was carried out and completed as described in this operating manual.

Depending on the field of application, the operation safety order must be observed.

Check the data on material, pressure, temperature, voltage and flow direction with the layout plan of the pipework system. In addition, check whether the operating conditions correspond to the technical data in the data sheet or on the rating plate.

7.2 Troubleshooting plan

Malfunction	Possible causes	Remedy
no flow in case of MRK Ro Ma	Flow control butterfly valve does not open	Switch on solenoid drive (800)
		Check tension
no flow in case of MRK Ro Ma..R	Flow control butterfly valve does not open	Switch off solenoid drive (800)
		Check tension
	Operating pressure too high	Compare operating pressure with instructions of type plate
low flow	Obstruction in pipe system	Check pipe system
	Setting of basic and main volume	Check setting of basic, or respectively main volume
External leakage	Sealing damaged	See section 8 or exchange flow control butterfly valve
Disc does not close	Setting of basic and main volume	Check setting of basic, or respectively main volume
	Existing tension too high	Check for residual tension see section 4.1



NOTICE!

Observe section 9.0 before all installation and repair work!

Observe section 6.4 when putting the valve back into operation!

8.0 Dismantling of the Flow control butterfly valve

In addition to the general installation guidelines and the operation safety order, the following points must also be observed:



DANGER!

- Depressurised pipework system
- Cooled medium
- Emptied installation
- Vent pipework systems containing corrosive, inflammable, aggressive or toxic media
- Have dismantling work carried out only by qualified staff (see point 2.3)

8.1 Replacement of wear parts

Shut down the flow control butterfly valve as described in section 6.2.

Switch off and dismantle the solenoid drive as described in the operating manual of the solenoid drive.



DANGER!

After continuous operation, the solenoid drive may be hot! Danger of burns!

MKR Ro Ma / MRK Ma..Ü200	Fig.1
MKR Ma..Ü550	Fig.2
MRK Ma Ü700	Fig.3
MRK Ma Ü1000	Fig.4

Replace the complete flow control butterfly valves.

9.0 Warranty

Scope and period of the warranty is specified in the edition of the “General Terms of Business of the UNI-Geräte E. Mangelmann Elektrotechnische Fabrik GmbH” valid at the time of delivery or else in the purchase agreement.

We warranty that the valve is free from faults in line with the state of the art and for the confirmed field of application.

No warranty claims will be accepted for damage resulting from improper use or failure to observe these operating and installation instructions, the statutory accident prevention regulations, the EN, DIN and VDE standards and other codes and regulations.

Warranty claims will also not be accepted for damage occurring during operation due to operating conditions deviating from those specified in the data sheet or in other agreements.

Justified complaints will be remedied by reworking by us or specialist companies authorised by us.

Claims going beyond the scope of the warranty will not be accepted. The customer shall have no right to the supply of a replacement valve.

Maintenance work, installation of parts from other manufacturers, any modifications to the design and natural wear are not covered by the warranty.

Transport damage must be reported not to us but **without delay** to your responsible goods handling company, the railway company or the shipping agent as otherwise all claims for damages against these companies will be voided.

10.0 Explanations on Codes and Directives

The Commission of the European Union has laid down common directives for the free trading of goods within the Union specifying minimum requirements for safety and health protection. The CE symbol confirms that products comply with the EU directives, i.e. in conformity with the relevant, in particular harmonised standards. Regulation EU/2016/426 and Directive 2014/68/EU are of relevance for the gas solenoid valve (mechanical part).

Notes on Regulation EU/2016/426 (Gas Appliances Regulation, GAR):

The valves have been developed, manufactured and tested in accordance with harmonised standard DIN EN 161 and DIN EN 16678 and comply with the relevant requirements of the Union Regulation EU/2016/426. Unless otherwise stated separately, this has been confirmed by a type test.

Notes on Directive 2014/68/EU (Pressure Equipment Directive, DGRL):

It has been confirmed that the quality assurance in design control, manufacture and final acceptance of the manufacturer, UNI-Geräte E. Mangelmann Elektrotechnische Fabrik GmbH, satisfy the requirements of 2014/68/EU Article 14 Module H. The gas solenoid valves comply with the fundamental requirements of Directive 2014/68/EU. Valves in according to Article 1 Paragraph 2,f,v or Article 4 paragraph 3 are not allowed to have the CE Mark in according to Article 18.

Note concerning ex-guideline 2014/34/EU (explosion guideline ATEX):

The product is not subject to guideline 2014/34/EU, since due to the loads occurring during practical operation, there is no effective source of ignition even in case of an error case to be assumed. This also applies to spring loaded components in gas-filled rooms. In case of electric drives, sensors or other electric components the application as per 2014/34/EU is to be checked separately.

11.0 Sectional drawing

11.1 Fig.1 MRK Ro Ma / MRK Ma..Ü200

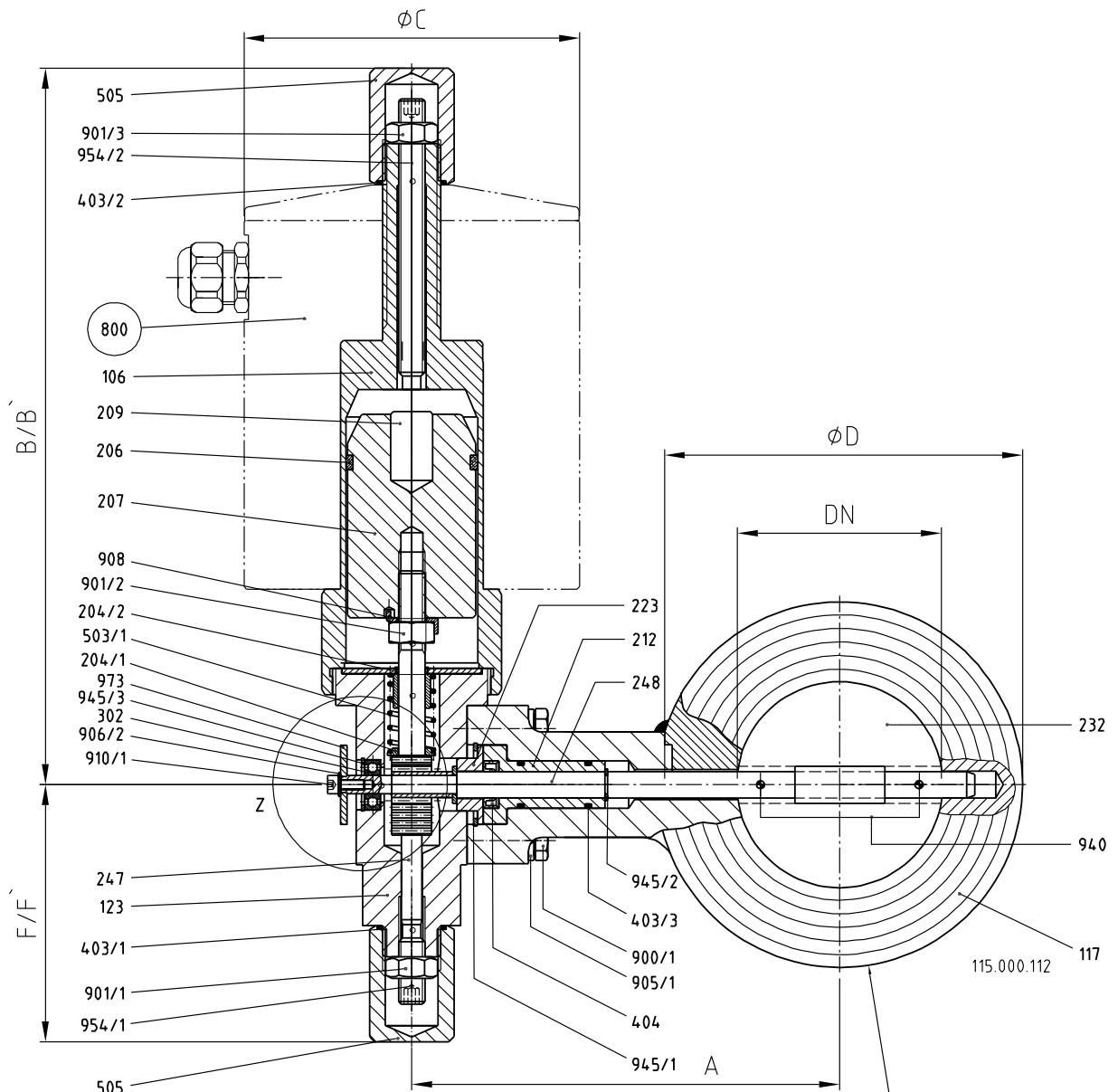

Option Ansicht Endschalteranbau
Option opinion limit switch mounting
Z 2:1

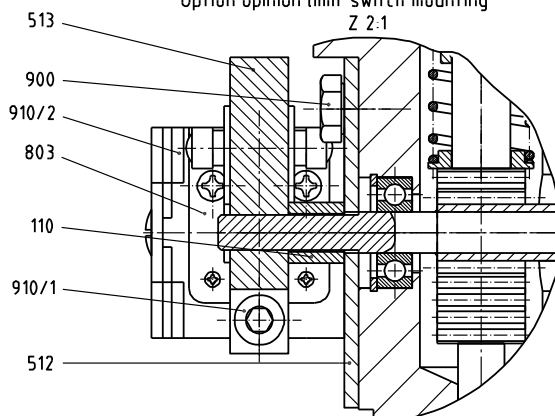

Der Klappenring ist bei W-Ausf. um 90° gedreht
By butterfly ring, vertical (W) design, turn through 90°

B' / F' = Maß zum Abschrauben der Schutzkappe
= clearance for removal of the threaded protective cap

E = Einbaubreite des Klappenringes
Installation clearance of butterfly ring

Fig.2 MRK MA Ü550

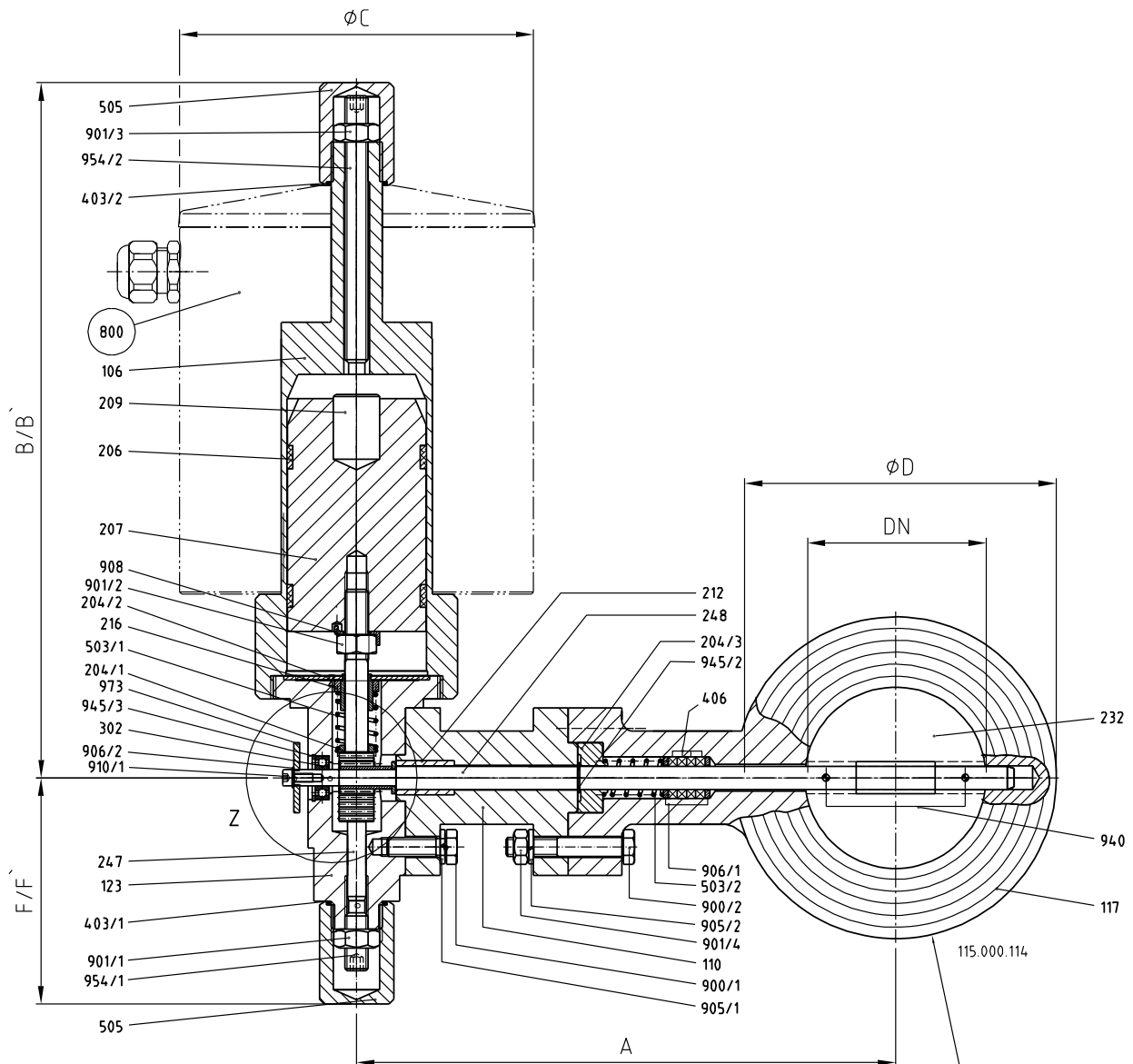

Der Klappenring ist bei W-Ausf. um 90° gedreht
By butterfly ring, vertical (W) design, turn through 90°

Option Ansicht Endschalteinbau
Option opinion limit switch mounting
Z 2:1

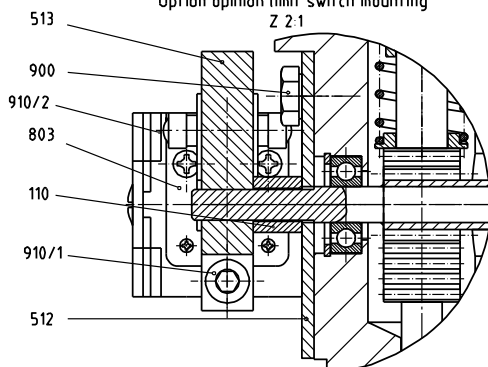

B' / F' = Maß zum Abschrauben der Schutzkappe
= clearance for removal of the threaded protective cap

E = Einbaubreite des Klappenringes
Installation clearance of butterfly ring

Fig.3 MRK MA Ü700

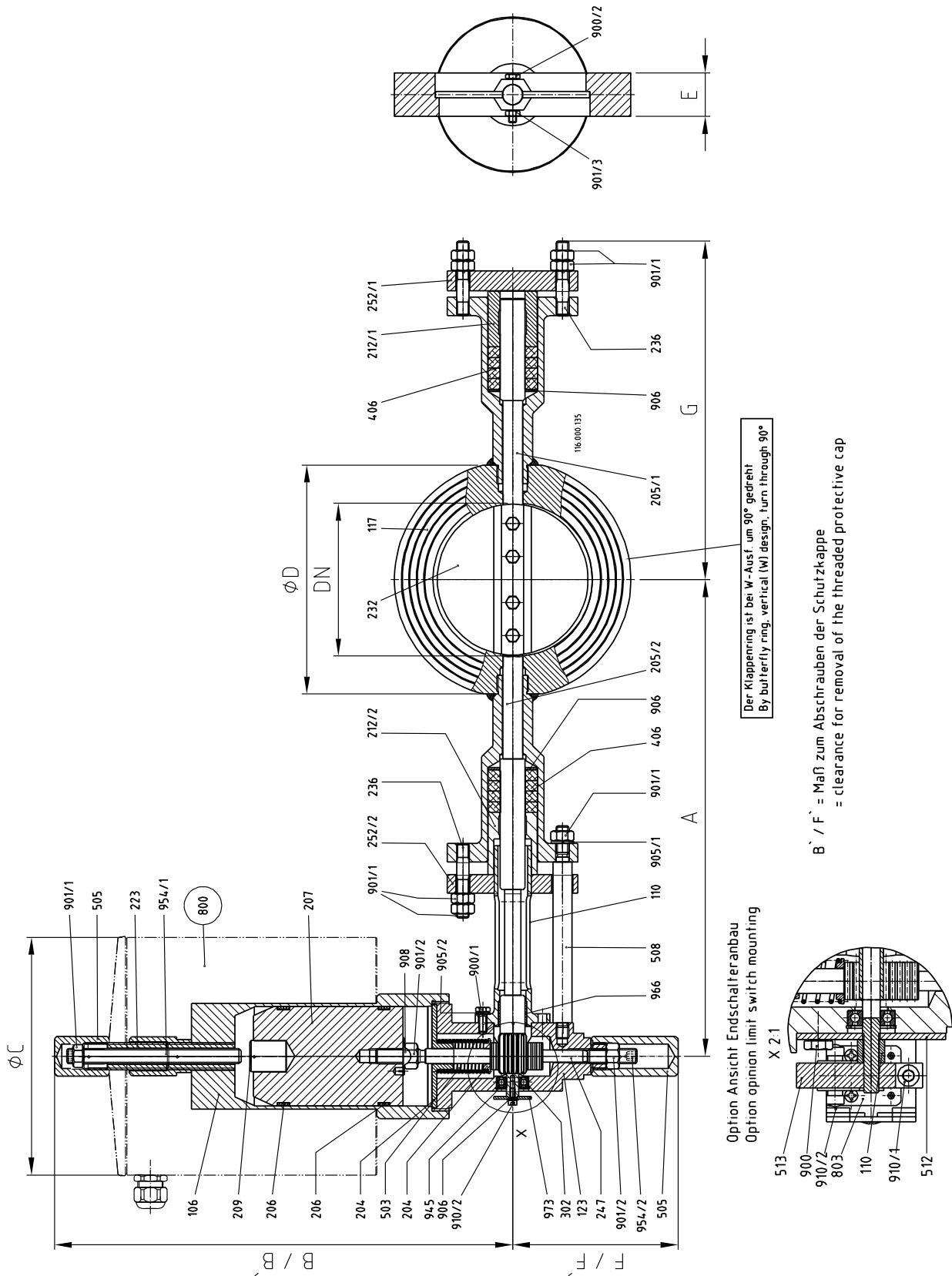
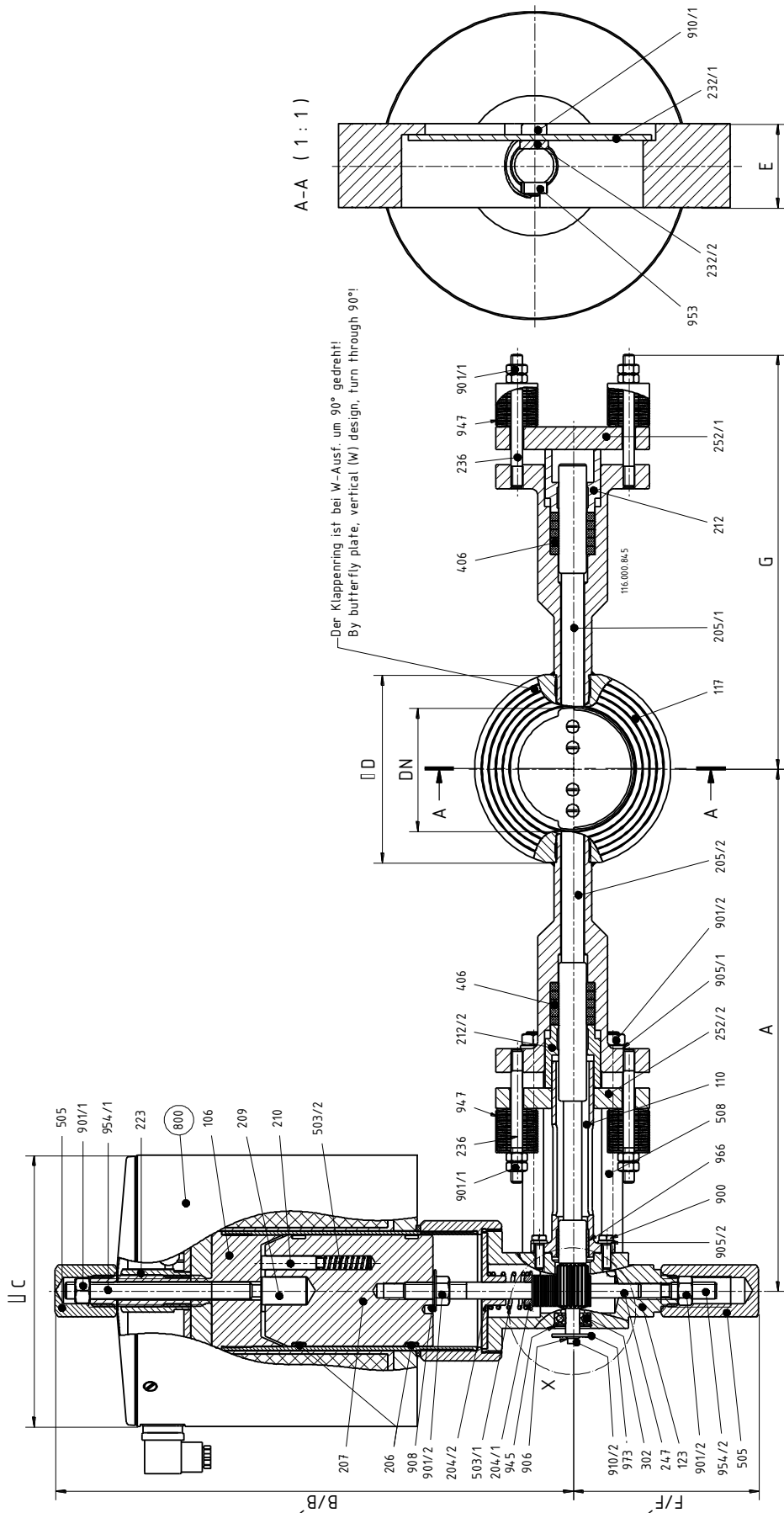
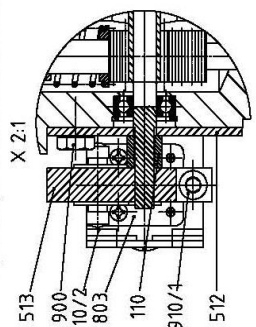

Fig.4 MRK MA Ü1000



Option Ansicht Endschalteranbau
Option opinion limit switch mounting



B' / F' = Maß zum Abschrauben der Schutzkappe
= clearance for removal of the threaded protective cap

Fig.5 Version butterfly plate

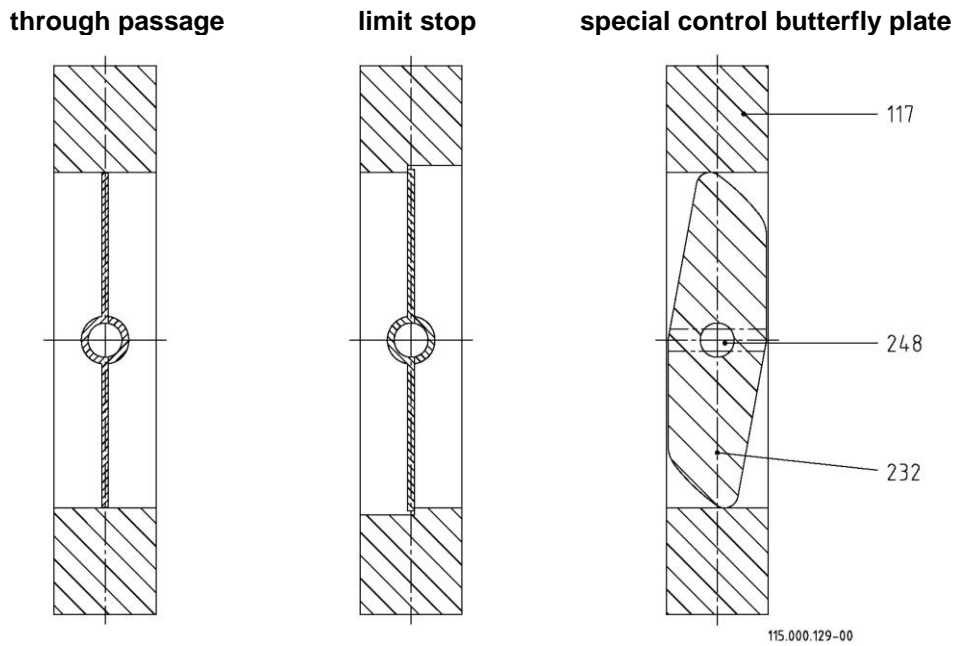
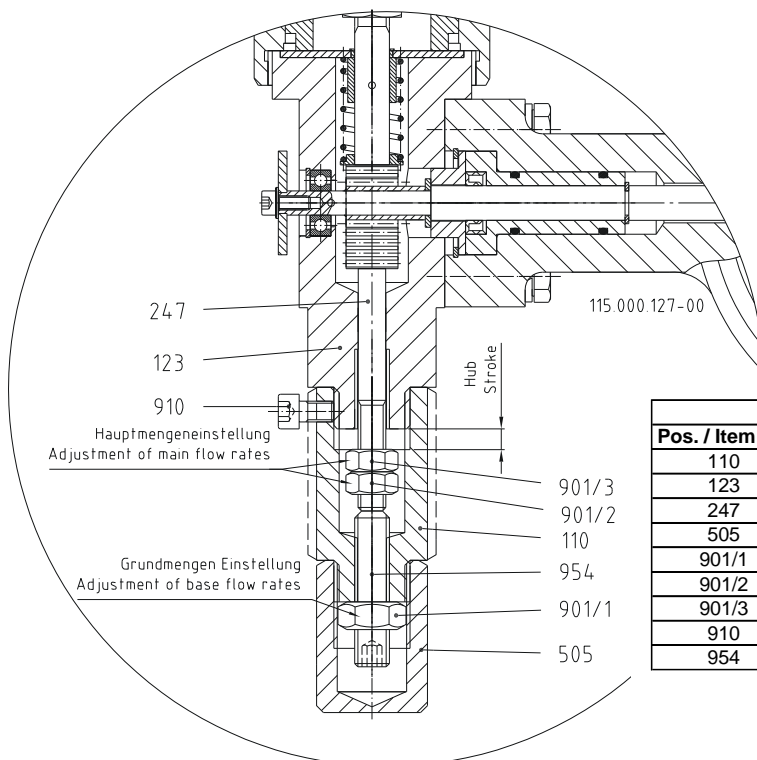

Fig.6 Setting of main and basic volume of EEx – solenoid drive MG008-2x – MG019x



Stückliste / list of parts			
Pos. / Item no.	Stück / Qty.	Benennung	Denomination
110	1	Distanzstück	spacer
123	1	Klappengehäuse	butterfly housing
247	1	Zahnstange	toothed rack
505	1	Schutzkappe	protective cap
901/1	1	Sechskantmutter	hex. nut
901/2	1	Sechskantmutter	hex. nut
901/3	1	Sechskantmutter	hex. nut
910	1	Zylinderschraube	cylinder head screw
954	1	Einstellstift	Adjusting pin

Fig.7 Limit switch installation with one or two limit switches with one limit switch actuation

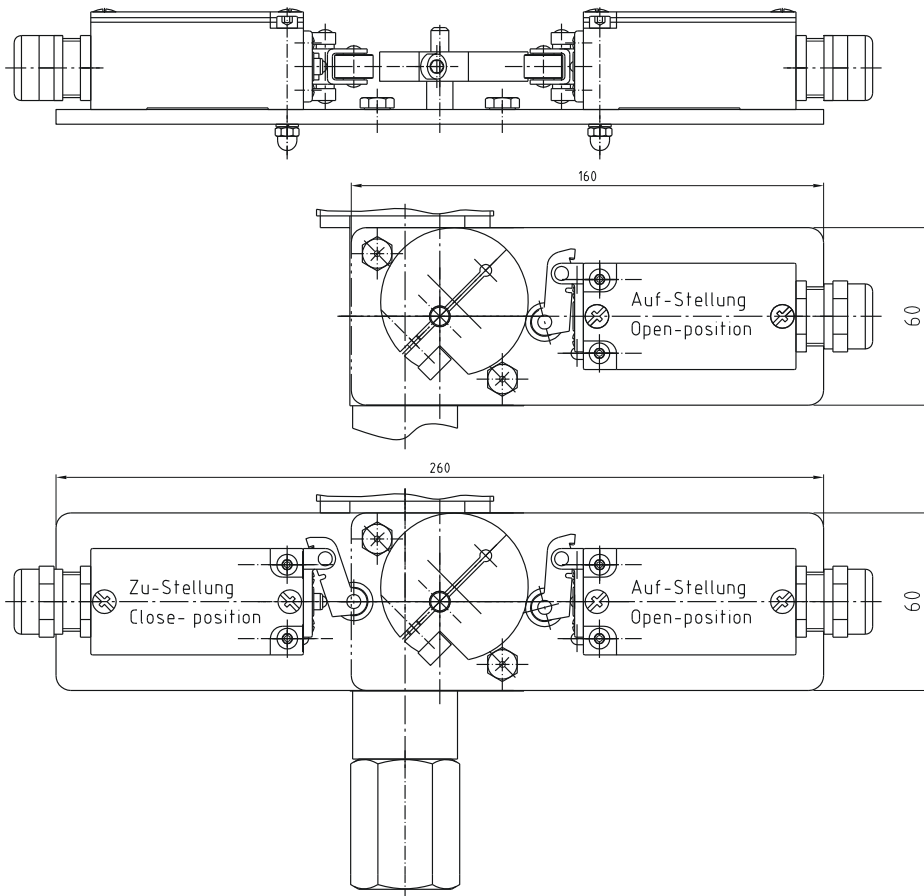
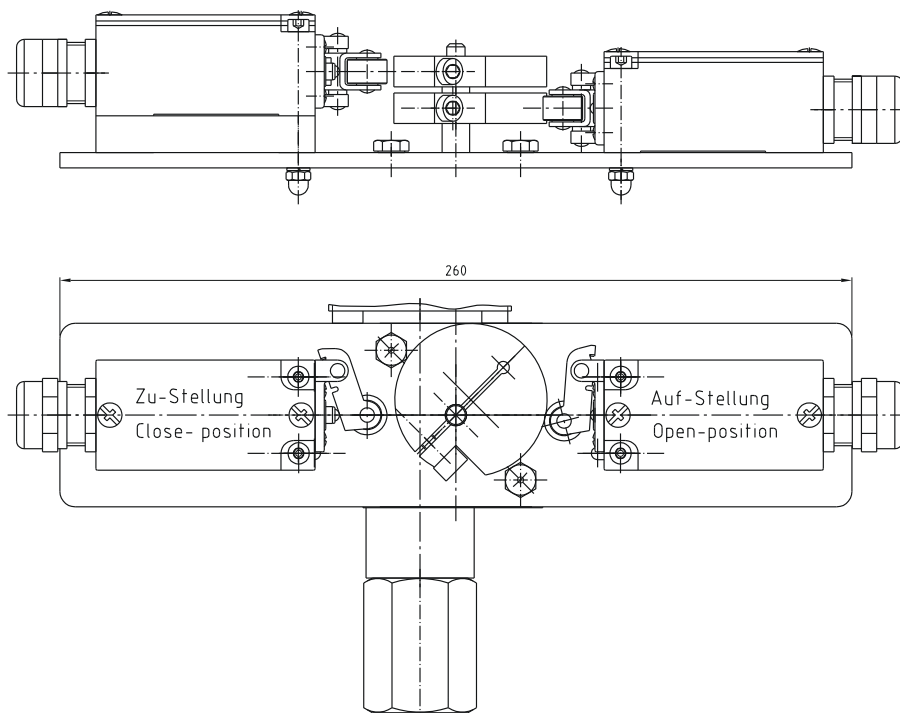

Fig.8 Limit switch installation with two limit switches and with two limit switch actuations



115.000.115-00

11.2 List of parts

Item	Qty	Description	Item	Qty	Description
101	1	Housing nut	900/1	4	Hex. head screw
106	1	Upper part of housing	900/2	4	Hex. head screw
110	1	Spacer	901/1	1	Hex. nut
117	1	Butterfly ring	901/2	1	Hex. nut
123	1	Butterfly housing	901/3	1	Hex. nut
204/1	1	Spring guide	901/4	4	Hex. nut
204/2	1	Spring guide	905/1	4	Lock washer
204/3	1	Spring guide	905/2	4	Lock washer
206	2	Guide ring	906/1	1	Washer
207	1	Solenoid core	906/2	1	Washer
209	1	Discharge bolt	908	1	Locking plate
212	1	Spindle guide	910/1	1	Cylinder head screw
216	1	Spring disc	910/2	3	Cylinder head screw
223/1	1	Bush	940	2/4	Semi-round rivetting
223/2	1	Bush	945/1	1	Safety ring
223/3	1	Bush	945/2	1	Safety ring
232	1	Butterfly plate	945/3	1	Safety ring
247	1	Toothed rack	947	4	disk spring packages
248	1	Toothed spindle	953	3	Round nut
302	1	Deep groove ball bearing	954/1	1	Adjusting pin
402	1	Gasket	954/2	1	Adjusting pin
403/1	1	O-ring	973	1	Scale
403/2	1	O-ring	Only by limit switch mounting		
403/3	2	O-ring	110	1	Spacer
404	1	Lip-ring	512	1	Limit switch console
406	4	Packing	513	1/2	Switch actuator
503/1	1	Pressure spring	803	1/2	Limit switch
503/2	1	Pressure spring	900	2	Hex. head screw
505	2	Protective cap	910/1	1/2	Cylinder head screw
800	1	Solenoid drive	910/2	2/4	Cylinder head screw

Spare parts

Version	Fig.	Type	spare parts
MRK Ro Ma	Fig. 1	MRK Ma 5N - 400	Solenoid drive (800)
MRK Ma...Ü200	Fig. 1	MRK Ma 5N - 400	Solenoid drive (800)
MRK Ma...Ü550	Fig. 2	MRK Ma 5N - 400	Solenoid drive (800)
MRK Ma...Ü700	Fig. 3	MRK Ma 5N - 400	Solenoid drive (800)
MRK Ma...Ü1000	Fig. 4	MRK Ma 5N - 150	Solenoid drive (800)

Dimension with standard solenoid drive MRK (Ro) Ma (R)

Type	Dimension	DN						
		15 / 20 (5N/7N)	25 / 32 (10N/12N)	40 (15N)	50 (20N)	65 (25N)	80 (30N)	100
MRK Ro Ma.. MRK Ma...Ü200	A	133	139	142	147	154	162	172
	B	255	255	272	272	272	272	272
	B'	305	305	305	305	305	305	305
	ØC	127	127	127	127	127	127	127
	ØD	50	70	92	96	125	140	162
	E	25	25	25	25	25	30	30
	F	92	92	97	97	97	97	97
MRK Ma...Ü550	A	133	139	142	147	155	162	172
	B	285	285	285	285	285	285	285
	B'	335	335	335	335	335	335	335
	ØC	127	127	127	127	127	127	127
	ØD	50	70	90	105	125	140	160
	E	25	25	25	25	25	30	30
	F	92	92	92	92	92	92	92
F'	140	140	140	140	140	140	140	

Type	Dimension	DN						
		15 / 20 (5N/7N)	25 / 32 (10N/12N)	40 (15N)	50 (20N)	65 (25N)	80 (30N)	100
MRK Ma...Ü700	A	325	337	348	354	364	372	385
	B	297	297	370	370	370	370	370
	B'	347	347	415	415	415	415	415
	ØC	153	153	191	191	191	191	191
	ØD	50	70	90	105	125	140	160
	E	25	25	25	25	25	30	30
	F	133	133	133	133	133	133	133
	F'	200	200	200	200	200	200	200
MRK Ma...Ü1000	A	325	361	348	355	364	372	385
	B	297	370	370	362	370	370	370
	B'	347	415	415	415	415	415	415
	ØC	191	191	191	191	191	191	191
	ØD	95	115	140	105	125	140	160
	E	45	45	45	45	45	45	55
	F	133	133	133	133	133	133	133
	F'	200	200	200	200	200	200	200
G	249	259	269	273	286	296	304	

Type	Dimension	DN						
		125	150	200	250	300	350	400
MRK Ro Ma.. MRK Ma...Ü200	A	185	197	236	261	286	336	356
	B	272	318	335	365	365	370	430
	B'	305	355	385	415	415	420	480
	ØC	127	153	153	191	191	191	230
	ØD	191	215	270	310	370	428	465
	E	35	35	40	40	45	45	50
	F	97	97	110	110	110	110	110
	F'	140	140	160	160	160	160	160
MRK Ma...Ü550	A	255	267	355	380	405	455	520
	B	285	297	360	373	373	373	430
	B'	335	347	410	425	425	425	480
	ØC	153	153	191	191	191	191	230
	ØD	190	215	270	320	370	428	465
	E	35	35	40	40	45	45	50
	F	92	92	110	110	110	110	110
	F'	140	140	160	160	160	160	160
MRK Ma..Ü700	A	383	396	423	450	475	502	525
	B	370	370	405	409	409	409	430
	B'	415	415	446	459	459	459	480
	ØC	191	191	230	230	230	230	230
	ØD	190	215	270	320	370	428	465
	E	35	35	40	40	45	45	50
	F	133	133	133	133	133	133	133
	F'	200	200	200	200	200	200	200
MRK Ma..Ü1000	A	383	396	-	-	-	-	-
	B	370	370	-	-	-	-	-
	B'	415	415	-	-	-	-	-
	ØC	191	191	-	-	-	-	-
	ØD	190	215	-	-	-	-	-
	E	55	55	-	-	-	-	-
	F	133	133	-	-	-	-	-
	F'	200	200	-	-	-	-	-
G	306	319	-	-	-	-	-	

Dimension B, (B') and Ø C change for solenoid drives for explosion-proof zone 1.
Please observe the dimensions of the attached relay combination for drives with "A1, A2, A3" in the type designation.

12.0 Declaration of Conformity

UNI-Geräte E. Mangelmann
Elektrotechnische Fabrik GmbH
Holtumsweg 13
D – 47652 Weeze



EU

Konformitätserklärung

Declaration of Conformity

Produkt / Product	Stellgerät zum Regeln ohne Nullabschluss / <i>Control actuator without zero shut off</i>		
Handelsbezeichnung / Trade Mark	Mengenregelklappe / Flow control butterfly valve		
Baureihe / Series	...MRK...		
Nennweiten / Size	DN 15 ^{a)} / 20 ^{a)} / 25 ^{a)} / 32 ^{a);b)} / 40 ^{a);b)} / 50 ^{a);b)} / 65 ^{a);b)} / 80 ^{a);b)} / 100 ^{a);b)} / 125 ^{a);b)} / 150 ^{a);b)} / 200 ^{a);b)} / 250 ^{a);b)} / 300 ^{a);b)} / 350 ^{a);b)} / 400 ^{a);b)}		
Druckstufe / Pressure Stage	PN 10 ^{b)} / 16 ^{a)}		
Fluidgruppe / Fluid Group	Brennbare Gase, FL. Gr.1 / <i>Flammable gases, FL. Gr.1</i>		
EU - Richtlinien / EU - Directives	EU/2016/426 ^{a)} Gasgeräteverordnung / <i>Gas Appliance Regulation</i> 2014/68/EU ^{b)} Druckgeräterichtlinie / <i>Pressure Equipment Directive</i>		
Konformitätsbewertungsverfahren / <i>Conformity Assessment Procedure</i>	Modul B + D - EU/2016/426 ^{a)} ; Modul H - 2014/68/EU ^{b)}		
Angewandte technische Spezifikation / <i>Applied Technical Specification</i>	^{a)} DIN EN 16678:2016-02; DIN EN 13611:2016-09; ^{b)} DIN EN 16668:2018-05; DIN EN 12266:2012-04		
Baumusterprüfung / <i>Type Examination</i>	CE-0085AR0408 ^{a)} DVGW CERT GmbH Josef-Wirmer-Str. 1-3 D-53123 Bonn Zertifizierungsstelle / <i>Notified Body 0085</i>	EU/2016/426	Modul B
Überwachungsverfahren / <i>Surveillance Procedure</i>	SE-0085BL7038 ^{a)} DVGW CERT GmbH Josef-Wirmer-Str. 1-3 D-53123 Bonn Zertifizierungsstelle / <i>Notified Body 0085</i>	EU/2016/426	Modul D
	CE-0062-PED-H-UGM 001-23-DEU ^{b)} Bureau Veritas Services SAS 8 Cours du Triangle 92800 PUTEAUX – LA DEFENSE Zertifizierungsstelle / <i>Notified Body 0062</i>	2014/68/EU	Modul H
Kennzeichnung / Marking	CE - 0085 ^{a)} 0062 ^{b)} oder/lor CE - 0085 ^{a)} oder/lor CE - 0062 ^{b)}		

Das Unternehmen UNI Geräte E. Mangelmann Elektrotechnische Fabrik GmbH erklärt in alleiniger Verantwortung, dass die o.a. Baureihe die grundsätzlichen Anforderungen der aufgeführten Richtlinien und Normen erfüllt.

UNI Geräte E. Mangelmann Elektrotechnische Fabrik GmbH confirms under the sole responsibility of the manufacturer, that the basic requirements of the above specified directives and standards are fulfilled.

Weeze, 24.01.2023

Ort und Datum / *place and date*

Geschäftsführer / *Managing Director*
Norbert Schneider

^{a); b)} Anwendung in Abhängigkeit von Nennweite und / oder Druckstufe: / *Application depending on size and / or pressure stage:*
DN ≤ 25 und / oder PS ≤ 0,5bar siehe Diagramm 6, oder Kat.1 + erfasst von EU/2016/426, fallen nicht in den Anwendungsbereich der 2014/68/EU
DN ≤ 25 and / or PS ≤ 0,5bar see diagram 6, or Kat.1 + under the scope of EU/2016/426, are not covered by the scope of the EU-Directive 2014/68/EU
250.100.008-05

UNI-Geräte E. Mangelmann
Elektrotechnische Fabrik GmbH
Holtumsweg 13
D – 47652 Weeze



UK Declaration of Conformity UK Konformitätserklärung

We / Wir:

UNI-Geräte E. Mangelmann
Elektronische Fabrik GMBH
Holtumsweg 13
D – 47652 Weeze

Declare that / Erklären hiermit:

Product / Produkt

Functional Control – without zero obturation
Stellgerät – ohne Nullabschluss

Trade Mark / Handelsbezeichnung

Flow control butterfly valve / Mengenregelklappe

Series / Baureihe

MRK...

Size / Nennweiten

DN 15 / 20 / 25 / 32 / 40 / 50 / 65 / 80 / 100 / 125 / 150 / 200 / 250 / 300 /
350 / 400

Pressure Stage / Druckstufe

PN 16

Fluid Group / Fluidgruppe

Gas type of the 1st, 2nd and 3rd family gases
Gasart der 1., 2. und 3. Gasfamilie

Satisfies the essential requirements of the Regulation 2016/426 on gas appliances as brought into UK law and amended and is manufactured in accordance with the UK designated standards:

Erfüllt die grundlegenden Anforderungen der Verordnung 2016/426 für Gasgeräte in der im Vereinigten Königreich geltenden und geänderten Fassung und wird in Übereinstimmung mit den im VK festgelegten Normen hergestellt:

Standards Numbers / Normen Nummern: BS EN 161:2011+A3:2013, BS EN 16678:2015

BSI has performed the following conformity assessment procedures specified in the Regulation 2016/426 on gas appliances as brought into UK law and amended:

Das BSI hat die folgenden Konformitätsbewertungsverfahren durchgeführt, die in der Verordnung 2016/426 für Gasgeräte, wie sie inritisches Recht umgesetzt und geändert wurde, festgelegt sind:

Annex III Module B (Type Examination) and issued the Certificates below:

UKCA Module B certificate: (Certificate No.) UKCA 772967

*Anhang III Modul B (Baumusterprüfung) geprüft und die nachstehenden Bescheinigungen ausgestellt:
UKCA-Modul-B-Zertifikat: (Zertifikats-Nr.) UKCA 772967*

Annex III Module D (Conformity to Type based on Quality Assurance of the Production Process) and issued the Certificates below:

UKCA Module D certificate: (Certificate No.) UKCA 772905

*Anhang III Modul D (Konformität mit der Bauart auf der Grundlage der Qualitätssicherung des Produktionsprozesses) und stellte die nachstehenden Zertifikate aus:
UKCA-Modul-D-Zertifikat: (Zertifikats-Nr.) UKCA 772905*

Approved Body / Zugelassene Stelle:

BSI Assurance UK Limited (Approved Body No. 0086)

Address / Adresse:

**Kitemark Court, Davy Avenue,
Knowlhill Milton Keynes MK5 8PP UK.**

This declaration of conformity is issued under the sole responsibility of the manufacturer.

Diese Konformitätserklärung wird unter der alleinigen Verantwortung des Herstellers ausgestellt.

Name / Name:

Norbert Schneider

Title / Position / Funktion:

Dipl. Ing. / Managing Director / Geschäftsführer

Place & date of issue /

D – 47652 Weeze, 22.02.2023

Ort und Datum der Ausstellung:

Signature / Unterschrift:



250.100.581-00