

# Operating and mounting manual Safety shut off valve solenoid valve EV / EVF

## Contents

### 1.0 General Remarks

- 1.1 Valve data
- 1.2 Application

### 2.0 Danger Notices

- 2.1 Safety terms
- 2.2 Safety notice
- 2.3 Qualified staff
- 2.4 Unauthorized modification and spare part production
- 2.5 Unauthorized operation
- 2.6 Safety information for the use in explosion-prone areas guideline 2014/34/EU
- 2.7 Safety information regarding guideline 2014/68/EU attachment I

### 3.0 Handling

- 3.1 Transport
- 3.2 Storage
- 3.3 Handling before mounting

### 4.0 Product Description

- 4.1 Function
- 4.2 Technical data
- 4.3 Marking

### 5.0 Installation

- 5.1 Warning of dangers during installation, operation and maintenance
- 5.2 Installation

### 6.0 Operation

- 6.1 Commissioning
- 6.2 Shutting down
- 6.3 Maintenance
- 6.4 Putting back into operating

### 7.0 Troubleshooting

- 7.1 Detection of defects
- 7.2 Troubleshooting plan

### 8.0 Dismantling of the Valve

- 8.1 Replacement of wear parts

### 9.0 Warranty

### 10.0 Explanations on Codes and Directives

### 11.0 Drawing

- 11.1 Sectional drawing
- 11.2 View drawing
- 11.3 List of parts

### 12.0 Declaration of Conformity

## 1.0 General Remarks

This operating manual includes instructions to assemble and operate the valve in the prescribed and safe way. **Additionally, the adequate operating instructions of each special solenoid drive must be considered.**

Series MG...	220.000.038
Series MG...X	220.000.040
Series MG...Xme	220.000.039

If any difficulties appear that can not be solved by means of the operation manual, further information may be demanded from the manufacturer.

This operating manual is in accordance with the relevant valid EN safety standards and the valid prescriptions and rules of the Federal Republic of Germany.

If the solenoids are used abroad of the FRG, the operator and/or the person who is responsible for the plant concept must take care that the valid national rules are met. The manufacturer reserves the right of any technical change and improvement. The use of these operating instructions suppose the qualification of the user according to paragraph 2.3 "qualified staff".

The operating staff must be trained in accordance with the operating instructions. The operating manual must always be available at the location where used.

### 1.1 Valve data

#### Manufacturer:

UNI Geräte E. Mangelmann  
Elektrotechnische Fabrik GmbH  
Holtumsweg 13  
D-47652 Weeze  
Telefon: +49 (0) 2837/9134-0  
Fax: +49 (0) 2837/1444  
E-Mail: [info@uni-geraete.de](mailto:info@uni-geraete.de)  
Homepage: [www.uni-geraete.de](http://www.uni-geraete.de)

#### Designation

Directly functioning, currentless closed, spring safety shut off valve with solenoid drive.

**Type test acc.** to DIN EN 264

**Working pressure:**

5 EV(F)	5bar
10 EV(F)	10bar
25 EV(F)	25bar
40 EV(F)	40bar

**Medium temperature:**

EV	-10°C to + 140°C	(263K to 413K)
EVF	-10°C to + 200°C	(263K to 473K)

**Ambient temperature:** -10°C to + 60°C (263K to 333K)

**Fitting position:** vertical drive  $\pm 5^\circ$ , with order supplement „W“ horizontal drive

**Working pressure:** 100-EVF 5 / 7 16bar  
**Medium temperature:** -20°C to + 200°C (253K to 473K)  
**Ambient temperature:** -20°C to + 60°C (253K to 333K)  
**Fitting position:** vertical or horizontal drive

**Working pressure:** 100-EVF 10N 100bar  
**Medium temperature:** -10°C to + 200°C (263K to 473K)  
**Ambient temperature:** -10°C to + 60°C (263K to 333K)  
**Fitting position:** vertical drive

**Switching cycles:** see operating instructions solenoid drive

**EV with flange connection measures acc. to DIN EN 1092-2 / ANSI**

Flange DN	PN	TÜV- Report-no.	15 (5N)	20 (7N)	25 (10N)	32 (12N)	40 (15N)	50 (20N)	Test Pressure (*) PT
Flange ANSI			1/2	3/4	1	1 1/4	1 1/2	2	
5 EV..NÜ..92/93	25	S7/99	X	X	X	O	O	O	PT 16
10 EV..NÜ..92/93	40	S7/99	X	X	X	O	O	-	PT 25
25 EV..NÜ..92/93(#)	40	S7/99	X	X	X	O	O	-	PT 40
40 EV..NÜ..92/93	40	S7/99	X	X	X	O	-	-	PT 40

(\*) Test pressure to perform leakage test "NO FUNCTION TEST"

X Type test, O Acceptance test certificate 3.2 possible, - not available,

(#) For liquefied gas in its liquid form according to DIN 32725

**EVF with threaded connection dimension at DIN ISO 228-1**

Connection G	PN Class	TÜV- Report-no.	1/2 (5)	3/4 (7)	1 (10)	1 1/4 (12)	1 1/2 (15)	2 (20)	Test pressure (*) PT
100-EVF...	100 900/1500	-	O	O	-	-	-	-	PT 100

(\*) Test pressure to perform leakage test "NO FUNCTION TEST"

X Type test, O Acceptance test certificate 3.2 possible, - not available,

**EVF with flange connection measures acc. to DIN EN 1092-2 / ANSI**

Flange DN	PN	TÜV- Report-no.	15 (5N)	20 (7N)	25 (10N)	32 (12N)	40 (15N)	50 (20N)	Test Pressure (*) PT
Flange ANSI			1/2	3/4	1	1 1/4	1 1/2	2	
5 EVF..NÜ..92/93	40	S8/99	X	X	X	O	O	O	PT 16
10 EVF..NÜ..92/93	40	S8/99	X	X	X	O	O	-	PT 25
25 EVF..NÜ..92/93	40	S8/99	X	X	X	O	O	-	PT 40
40 EVF..NÜ..92/93	40	S8/99	X	X	X	O	-	-	PT 40
40 EVF..NH.Ü..	40	S8/99	X	X	X	-	-	-	PT 40
100 EVF..N..	100	-	-	-	O(**)	-	-	-	PT 100

(\*\*) Passage 13 mm

(\*) Test pressure to perform leakage test "NO FUNCTION TEST"

X Type test, O Acceptance test certificate 3.2 possible, - not available,

**Voltage:** VDC 12 – 440 (–15% bis +10%)  
VAC 24 – 500 (–15% bis +10%)  
**Protection type:** IP54 or IP65  
**Frequency:** 40 – 60 Hz  
**Power:** 10 – 4000W

Details to the electrical data can be found on the type sign and the adequate operating instructions of the solenoid drives.

**1.2 Application**

The UNI Geräte solenoid valves EV and EVF are used as automatic safety shut-off valves to secure, to limit, shut-down and release in oil and liquid gas heating installations and in steam boiler plant.

Qualified for fuel oil EL, M (EV) according to DIN 51603 and for liquid gas to DIN 51622 in liquid state and other liquids having a viscosity rate up to 75mm<sup>2</sup>/s and for fuel oil S (EVF).

If used in other cases, the operator must carefully check if construction/design of valve, accessories and materials are suitable for the new application. The range of application is subject to the responsibility of the plant planner. The service life of the valve is 20 years.

## 2.0 Danger Notices

### 2.1 Safety terms

The signal terms DANGER, CAUTION und NOTICE are used in this operating manual in case of notices concerning special dangers, or for unusual information requiring a special marking.



**DANGER!** means that in case of non-observance there is danger to life and/or considerable damage.



**CAUTION!** means that in case of non-observance there is danger of injury and/or damage.



**NOTICE!** means that attention is drawn to technical correlations/connections.

Observance of other, not especially marked notices concerning transport, assembly, operation and maintenance and other data (in the operating manual, product documentation and at the unit itself) is also essential, in order to avoid disturbances that might affect direct or indirect damage to property or injury to persons.

### 2.2 Safety notice

Non observance of safety instructions can lead to loss of any claim for damages.

Non observance can lead to the following mentioned dangers:

- Failure of important functions of the valve/plant
- Endangering of persons by electrical or mechanical influences.
- Protection against accidental contact for moving parts may not be removed as long as the valve is in operation.
- Leakage of dangerous media (e.g. explosive, toxic, hot) must be removed in the way that there is no danger for persons or environment. Laws and regulations must be observed.

### 2.3 Qualified staff

These are persons who are familiar with erection, assembly, starting, operation and maintenance of the product and who have special qualifications acc. to their activities and functions, e.g.:

- Instruction and obligation to carry out and meet all regional and in-house orders and requirements.
- Education or instruction according to the safety engineering standards in use and maintenance of adequate safety and working protection equipment.
- Training in first aid.

### 2.4 Unauthorized modification and spare part production

Modification or changes of the valve are only allowed after agreement of the manufacturer. Original drawings and accessories authorized by the manufacturer are for safety purposes. The use of other parts or unauthorized changes at the valve by third persons may cancel and abolish the manufacturer's liability for resulting consequences.

### 2.5 Unauthorized operation

Operational reliability of the delivered valve is only guaranteed in case of determined use in accordance to paragraph 1 of the operating manual. **The application limits mentioned on the type sign may on no account be exceeded.**

## 2.6 Safety information for the use in explosion-prone areas guideline 2014/34/EU

- The temperature of the medium must not exceed the respective temperature class, and respectively, the respective maximum permitted medium temperature as per operation guideline.
- If the valve is heated (e.g. heating jacket), care must be taken, that the specified temperature class is kept in the time.
- The valve must be connected to the ground.  
In the case most simple this can be realized via pipe screws by means of tooth disc.  
Otherwise the connection to the ground must be implemented by other measures e.g. cable links.
- Control valves, electrical and electrical/mechanical drives as well as sensors must undergo a separate conformity check as per ATEX. In doing so the respective safety and explosion protection information in the operation instructions are to taken into special consideration.
- Any modifications whatsoever to the valve are not allowed. The ATEX approval is void with immediate effect if the valve is modified without prior authorisation (even including painting).
- UNI-Geräte GmbH must be consulted before any modifications are made.

Furthermore we point out the guideline ATEX 118a, which include the minimum regulations for the improvement of the health-related situation and the safety of the employees, who might be jeopardized by an explosive atmosphere.

## 2.7 Safety information regarding guideline 2014/68/EU attachment I



### Danger!

UNI valves are not an accessory with a safety function as defined in the PED 2014/68/EU Article 2 (4) and Article 4 (1) (d) by category IV  
Use or classify!

## 3.0 Handling

### 3.1 Transport

For any transport works, the generally recognised technical rules and standards as well as rules for prevention of accidents must be observed.

During transport, storage and decommissioning, protective caps must be attached to the sides of the valve.

The goods to be transported must be carefully treated. During transport, the valve must be protected against strokes, impacts or vibration. The coat of lacquer may not be damaged. Transport temperature is  $-20^{\circ}\text{C}$  up to  $+60^{\circ}\text{C}$ .

**Never transport the valve at screwed cable glands, appliance plugs or add-on units.** The valve can be transported at ring nuts, flange borings or by means of a belt under the solenoid drive.

Transport the valve in a case or on a pallet with smooth base and put it softly on plain floor. **Never put the valve on attachment parts.**

The goods must be checked on completeness and transport damage. See also section 9.0

### 3.2 Storage

If the valve is not installed immediately after delivery, it must be stored properly.

- Storage temperature  $-20^{\circ}\text{C}$  up to  $+60^{\circ}\text{C}$ , dry and clean.
- The lacquering protects against corrosion in neutral dry atmosphere. Do not damage colour.
- In humid rooms, a drying agent or a heating resp. is necessary because of condensation of water.

Requirements according to DIN 7716 (products made of caoutchouc and rubber) must be met.

### 3.3 Handling before mounting

- In case of valve with protection caps, they must be removed before being mounted!
- Protect against atmospheric influences such as humidity.
- Appropriate treatment protects against damage.

## 4.0 Product Description

The UNI-Geräte solenoid valve of the series EV and EVF is a directly controlled, currentless closed shut-off valve with fast shut-off function as per DIN EN 264 (liquid gas in liquid gas phase as per DIN 51622) with solenoid drive.

Sectional drawing 11.1, Fig.1 – Fig. 6 shows the valve construction.

### 4.1 Function

By switching on the solenoid drive (800), the solenoid core (207) is drawn against the upper part of housing (106). The pressure spring (503) is pressed and the valve disc (200) opens the valve cross section. The valve is open.

The valve closes by switching off, interruption or failure of power energy to solenoid drive. Due to press of the pressure spring (503) the valve disc closes (200).The valve is closed.

### 4.2 Technical data

**Opening times:** 0,3 – 0,7s depends upon nominal width  
**Closing times:** < 1s

#### Solenoid –drive types MG...

Flange DN	15 (5N)	20 (7N)	25 (10N)	32 (12N)	40 (15N)	50 (20N)
Flange ANSI	1/2	3/4	1	1 1/4	1 1/2	2
5 EV...NÜ..92/93	014	014	016	018	019A5	019A2
10 EV...NÜ..92/93	016	016	019A5	018A2	019A1	-
25 EV...NÜA..92/93	016A	016A	018A2	019A2	019A3	-
25 EV...NÜA..92/93(#)	018A1	018A1	019A1	-	-	-
40 EV...NÜA..92/93	019A1	019A1	019A2	020A2	-	-

(#) For liquefied gas in its liquid

Connection G	1/2 (5)	3/4 (7)	1 (10)	1 1/4 (12)	1 1/2 (15)	2 (20)
100-EVF....	019A5	019A5	-	-	-	-

Flange DN	15 (5N)	20 (7N)	25 (10N)	32 (12N)	40 (15N)	50 (20N)
Flange ANSI	1/2	3/4	1	1 1/4	1 1/2	2
5 EVF...NÜ..92/93	014	014	016	019A5	019A5	019A2
10 EVF...NÜ..92/93	016	016	019A5	018A2	019A1	-
25 EVF...NÜA..92/93	016A	016A	018A2	019A2	019A3	-
40 EVF...NÜA..92/93	019A1	019A1	019A2	020A2	-	-
40 EVF...NH.Ü..	019A1	019A1	019A2	-	-	-
100 EVF...N..	-	-	019A5	-	-	-

Drive types with "A" consist of pickup and holding winding

#### Max. valve loading by pipe power

The indicated moments may not work longer than 10s.

DN		8	10	15	20	25	32	40	50	65	80	100	125	150
<b>Torsion</b>	Nm	20	35	50	85	125	160	200	250 <sup>1)</sup>	325 <sup>1)</sup>	400 <sup>1)</sup>	-	-	-
<b>Bending</b>	Nm	35	70	105	225	340	475	610	1100	1600	2400	5000	6000	7600

<sup>1)</sup> Not valid in case of valves with flanges

**Starting torque, pipe screws greased**

DN	8	10	15	20	25	32	40	50	65	80	100	125	150
Torque Nm	20	30	30	30	30	50	50	50	50	50	80	160	160

**Starting torque, product screws and nuts greased**

Screw	M6	M8	M10	M12	M16	M20	M24
Torque Nm	5	11	22	39	70	110	150

**4.3 Marking**

The type sign on the solenoid drive has the following information:

- Fabricator
- Valve type, nominal width, pressure and temperature indication, fitting position
- Year of construction/ production no.
- TÜV-report-no:
- Valve class and valve group acc. to DIN EN 264
- CE-sign and no. of relevant location to 2014/68/EU
- Fluid group and test pressure PT to 2014/68/EU
- Solenoid drive type
- Electr. performance
- Voltage
- Frequency
- Protection type

When using solenoid drives for ex-protection zone 1 refer to information in the valid operating instructions.

Refer also to section 10.0.

**5.0 Installation**

**5.1 Warning of dangers during installation, operation and maintenance**



**DANGER!**

Safe operation of the valve can only be guaranteed if it is installed, commissioned and maintained by qualified personnel (see point 2.3 “Qualified staff”) correctly and in observance of the warnings in this operating manual. Apart from that, the operation safety order and the qualified use of tools and protection equipment must be guaranteed. The operating instructions for the valve must be observed during all work on or with the valve. Failure to observe these instructions may result in injury or in damage to the valve or other installations.

When the valve is used as a final sealing element, a safety precaution e.g. blanking disc, blind flange, etc., in accordance with the code of practice of the German Technical and Scientific Association for Gas and Water (DVGW) is recommended during all repair work.

**5.2 Installation**

Apart from the general installation guidelines, the following points should be observed:



**NOTICE!**

- Remove protective caps.
- The inside of the valve and the pipeline must be free from foreign particles.
- Observe the installation position in relation to the flow direction, see markings on the valve.
- Centre gaskets between the flanges.
- The connecting flanges must be aligned.
- Ensure that none of the components is strained during installation.

- The valve must not be used as a fixed point; it is supported by the pipework system.
- Protect valves from soiling, particularly during construction work.
- Thermal expansion of the pipework must be equalized using compensators.

The valve can be installed with upright but not suspended solenoid drive. Valves with order suffix “W” in the type designation can be installed with horizontal solenoid drive.



**NOTICE!**

Please observe the solenoid drive operating instructions.

## 6.0 Operation



**DANGER!**

Before commissioning a new installation or before starting up an installation again after repairs or modifications, ensure:

- The proper completion of all installation and assembly work!
- Commissioning only by “qualified staff” (see point 2.3).
- Installation or repair of existing guards and protection equipment.

### 6.1 Commissioning

- Before commissioning, check the data on material, pressure, temperature and flow direction with the layout plan of the pipework system.
- Depending on the field of application, the local regulations have to be observed, e.g. the operation safety order.
- Residues in the pipework and the valve (dirt, weld beads, etc.) will inevitably result in leaks.
- Leakage inspection of the installed valve.

### 6.2 Shutting down

- Depending on the field of application, the local regulations have to be observed, e.g. the operation safety order.

### 6.3 Maintenance

Solenoid valves have to be checked at regular intervals for proper function and internal leak tightness. The intervals for regular inspections have to be defined by the operator according to the operating conditions. UNI-Geräte recommends an internal visual inspection once a year and an overhaul of the valve after 2 years or after the following number of switching cycles at the latest:

Application temperature	DN ≤ 25	≤ DN 80	≤ DN 150	> DN 150
≤ 25°C	150 000	75 000	25 000	20 000
> 25°C	50 000	25 000	25 000	5 000

**UNI-Geräte prescribes the following maintenance intervals for valves with SIL requirements:**

The safety requirements with regard to the maintenance intervals to be adhered are described in the **SIL manual** of the type series and must be complied with.

### 6.4 Putting back into operation

When putting a valve back into operation, ensure that all the necessary steps described in section 5.2 (Installation) and section 6.1 (Commissioning) are repeated.

### Repair or maintenance works at the manufacturing company (UNI- Geräte)



**DANGER!**

Valves and fittings must be delivered clean and free from substances which are harmful to health or to the environment.



## 7.0 Troubleshooting

### 7.1 Detection of defects



**DANGER!**

Be sure to observe the safety instructions during troubleshooting.

If the malfunctions cannot be remedied using the following “**Troubleshooting plan (7.2)**” please contact the manufacturer.

In the event of faults in the function or operating behaviour of the valve, check whether the installation work was carried out and completed as described in this operating manual.

Depending on the field of application, the operation safety order must be observed.

Check the data on material, pressure, temperature, voltage and flow direction with the layout plan of the pipework system. In addition, check whether the operating conditions correspond to the technical data in the data sheet or on the rating plate.

### 7.2 Troubleshooting plan

Malfunction	Possible causes	Remedy
No flow	Valve does not open	Switch on solenoid drive (800) Check operating voltage
	Working pressure too high	Compare working pressure with the data on the rating plate
	Protective caps were not removed	Remove protective caps
Low flow rate	Clogging in the pipework system	Check pipework system
Valve leaking at seat, no internal tightness	Valve disc sealing (400) or valve seat (100) damaged by external particles	See section 8 or replace valve
No external tightness	Gaskets damaged	See section 8 or replace valve
Valve does not close	Connected voltage too high	Check whether there is residual voltage, see section 4.1
Flange fracture (valve/pipework)	Screws not tightened uniformly, mating flanges not aligned	Align pipework. Install new valve



**NOTICE!**

Observe section 9.0 before all installation and repair work!

Observe section 6.4 when putting the valve back into operation!

## 8.0 Dismantling of the Valve

In addition to the general installation guidelines and the operation safety order, the following points must also be observed:



**DANGER!**

- Depressurised pipework system
- Cooled medium
- Emptied installation
- Vent pipework systems containing corrosive, inflammable, aggressive or toxic media
- Have dismantling work carried out only by qualified staff (see point 2.3)

## 8.1 Replacement of wear parts

Shut down the valve as described in section 6.2.

- Fig. 1 100-EVF... G1/2 – G3/4  
Fig. 5 100-EVF...N... DN25  
Fig. 6 40-EVF...NH... (DN15 – DN25)

### De-installation of the limit switch mounting

Switch limit switch (803) to zero-potential. Open limit switch housing (120). Loosen hexagon nut (901/2) and screw it off and remove it together with switch actuator (513) from the limit switch spindle (243). Loosen hexagon nut (901/3) and remove it. Take off the limit switch housing (120) with terminal box (716) from the connection piece limit switch (246). Remove connecting piece limit switch (246) from solenoid drive (800).

Switch off and dismantle the solenoid drive as described in the operating manual of the solenoid drive.



#### **DANGER!**

**After continuous operation, the solenoid drive may be hot! Danger of burns!**

Replace the complete solenoid valve.

- Fig. 2 5/10/25/40-EV...NÜ...  
Fig. 3 5/10/25/40-EVF...NÜ...  
Fig. 4 5/10/25/40-EVF...NÜ... (metal-of-metal sealing)

Switch off and dismantle the solenoid drive as described in the operating manual of the solenoid drive.



#### **DANGER!**

**After continuous operation, the solenoid drive may be hot! Danger of burns!**

During the visual inspection, pay attention to the following points:

1. Damage to the valve seat (100).
2. Damage to the valve disk sealing (400)
3. Wear of the guide rings (206)

In case of damage to the valve seat, replace the whole solenoid valve.

If the sealing element becomes damaged the spare parts kit should be used.

Loosen the setscrew (941). Loosen the upper part of housing (106) by turning to the right and screwing it off.



#### **NOTICE!**

The complete upper part of housing (106) is under spring power.

Remove spring bolt (210) with pressure spring (503) from the solenoid core (207). Release safety bolt (902/2) and remove it from the valve pin (214). Put the solenoid core (207) complete with valve pin (214) and dust guard membrane (407) onto a clear surface.

Loosen cylinder head screw (910/2) and pull off the limit switch actuator (513) from the valve spindle (205) and remove it.

Loosen hexagon nut (901/3) and remove it with limit switch consoles (512); remove limit switches (803) as well.



#### **NOTICE!**

Before doing so disconnect limit switch pos. 803.

**Fig. 2 5/10/25/40-EV ...NÜ... (lip ring sealing)**

Loosen cylinder head screws (910/1) and remove them with the lock washers (905/1). Remove spacer (110).

Lift the complete parts (115; 200/1; 201; 205; 212; 249; 902/1; 912 und 950) out of the valve housing (100). Pull of the guiding parts (115; 212; 249) from the valve spindle (205).

Remove split-pin (912) and pull out safety bolt (902/1).



**NOTICE!**

The ball (950) falls out.

Remove the complete valve disk (200/1).

**Fig. 3 5/10/25/40-EVF ...NÜ.. (sealing of expansion bellows)**

**Fig. 4 5/10/25/40-EVF ...NÜ.. (sealing of expansion bellows)**

Drive spring dowel sleeve (943) out of distort protection (227).

Loosen cylinder head screws (910/1) and remove them with the lock washers (905/1). Lift off spacer (110).

**Only by Fig. 3**

Lift the complete parts (200/2; 201; 205; 227; 400; 504, 507, 902/1, 912 und 950) out of the valve housing (100). Pull the distort protection (227) off the valve spindle (205).

**Only by Fig. 4**

Lift the complete parts (200/3; 205; 227; 504, 507, 902/1, 912 and 950) out of the valve housing (100). Pull the distort protection (227) off the valve spindle (205).

Remove split-pin (912) and pull out the safety bolt (902/1).



**NOTICE!**

The ball falls out (950).

Lift off the complete valve disk (200/2 or 200/3).

All parts marked as wear and tear parts are to be replaced. In case of damages at the valve disk sealing (400) the valve disk (200/1, 200/2) is to be replaced completely. In case of damages and drag lines at the valve disk (200/3) the latter is to be replaced completely. In case of cracks and pressure marks at the expansion bellows (504) the latter is to be completely removed including the bellow piece (507) resp. housing of expansion bellows (516).



**NOTICE!**

Before installation O-rings (403/X), gaskets (402/X), lip rings (404/X) and in case of sealing metal against metal the packing (406) are to be replaced.



**DANGER!**

For special application such as for oxygen use only the approved lubricants and appropriate sealing materials (BAM- approval).

Assemble the valve in the reverse order to the dismantling.



**CAUTION!**

Install wear parts carefully and properly and do not damage them during assembly.

Examine the valve for internal and external leaks and finally carry out a function test.

## 9.0 Warranty

Scope and period of the warranty is specified in the edition of the "General Terms of Business of the UNI-Geräte E. Mangelmann Elektrotechnische Fabrik GmbH" valid at the time of delivery or else in the purchase agreement.

We warranty that the valve is free from faults in line with the state of the art and for the confirmed field of application.

No warranty claims will be accepted for damage resulting from improper use or failure to observe these operating and installation instructions, the statutory accident prevention regulations, the EN, DIN and VDE standards and other codes and regulations.

Warranty claims will also not be accepted for damage occurring during operation due to operating conditions deviating from those specified in the data sheet or in other agreements.

Justified complaints will be remedied by reworking by us or specialist companies authorised by us.

Claims going beyond the scope of the warranty will not be accepted. The customer shall have no right to the supply of a replacement valve.

Maintenance work, installation of parts from other manufacturers, any modifications to the design and natural wear are not covered by the warranty.

Transport damage must be reported not to us but **without delay** to your responsible goods handling company, the railway company or the shipping agent as otherwise all claims for damages against these companies will be voided.

## 10.0 Explanations on Codes and Directives

The Commission of the European Union has laid down common directives, for the free trading of goods within the Union specifying minimum requirements for safety and health protection. The type test confirms that products comply with the EU directives, i.e. in conformity with the relevant, in particular harmonised standards. The directive DIN EN 264 refer to the solenoid valve (mechanical part).

### Notes concerning directives DIN EN 264:

The valves must be developed, manufactured and checked under observation of standard DIN EN 264. This is proven by the type test.

### Notes on Directive 2014/68/EU (Pressure Equipment Directive, DGRL):

It has been conformed that the quality assurance in design control, manufacture and final acceptance of the manufacturer, UNI-Geräte E. Mangelmann Elektrotechnische Fabrik GmbH, satisfy the requirements of 2014/68/EU Article 14 Module H. The solenoid valves comply with the fundamental requirements of Directive 2014/68/EU. Valves in according to Article 1 Paragraph 2,f,v or Article 4 paragraph 3 are not allowed to have the CE Mark in according to Article 18.

### Note concerning ex-guideline 2014/34/EU (explosion guideline ATEX):

The product is not subject to guideline 2014/34/EU, since due to the loads occurring during practical operation, there is no effective source of ignition even in case of an error case to be assumed. This also applies to spring-loaded components in the medium-conveying space. In case of electric drives, sensors or other electric components the application as per 2014/34/EU is to be checked separately.

### 11.0 Drawing

11.1 Fig. 1 100-EVF... (G1/2 – G3/4)

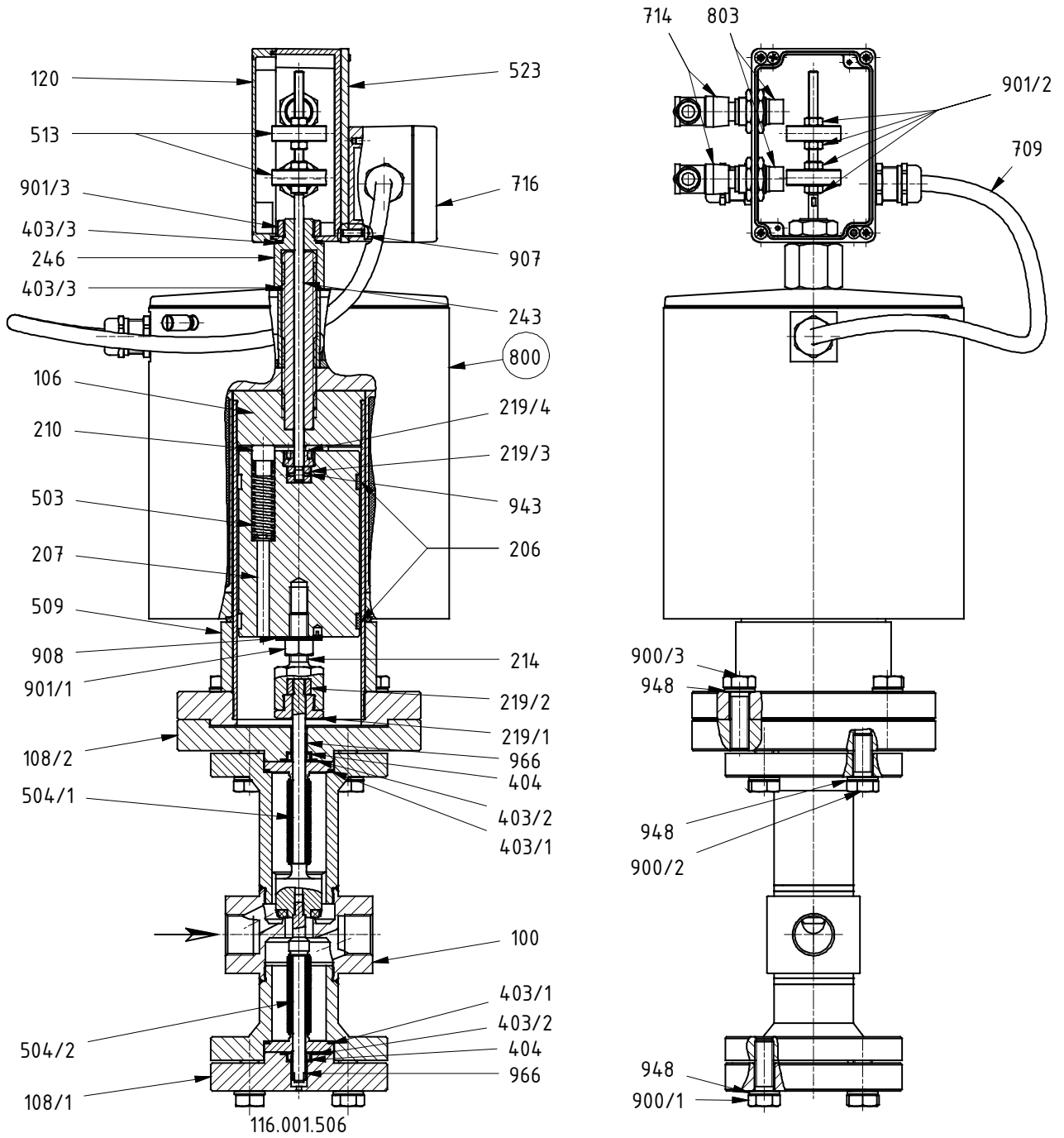



 = Spare part

Fig. 2 5/10/25/40-EV ...NÜ...

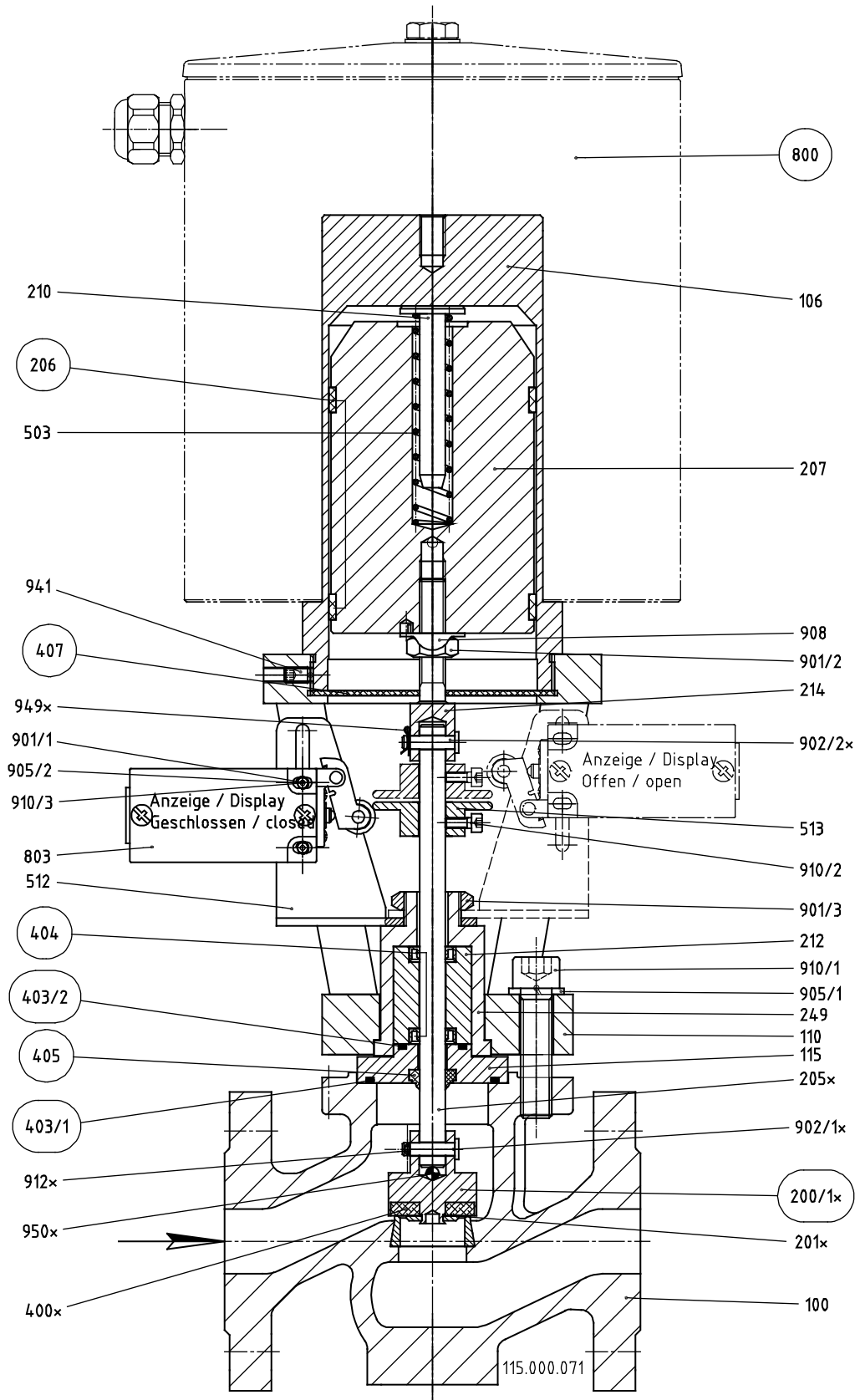

 = Spare part kit

(...x) supplied as a complete unit

Fig. 3 5/10/25/40-EVF ...NÜ...

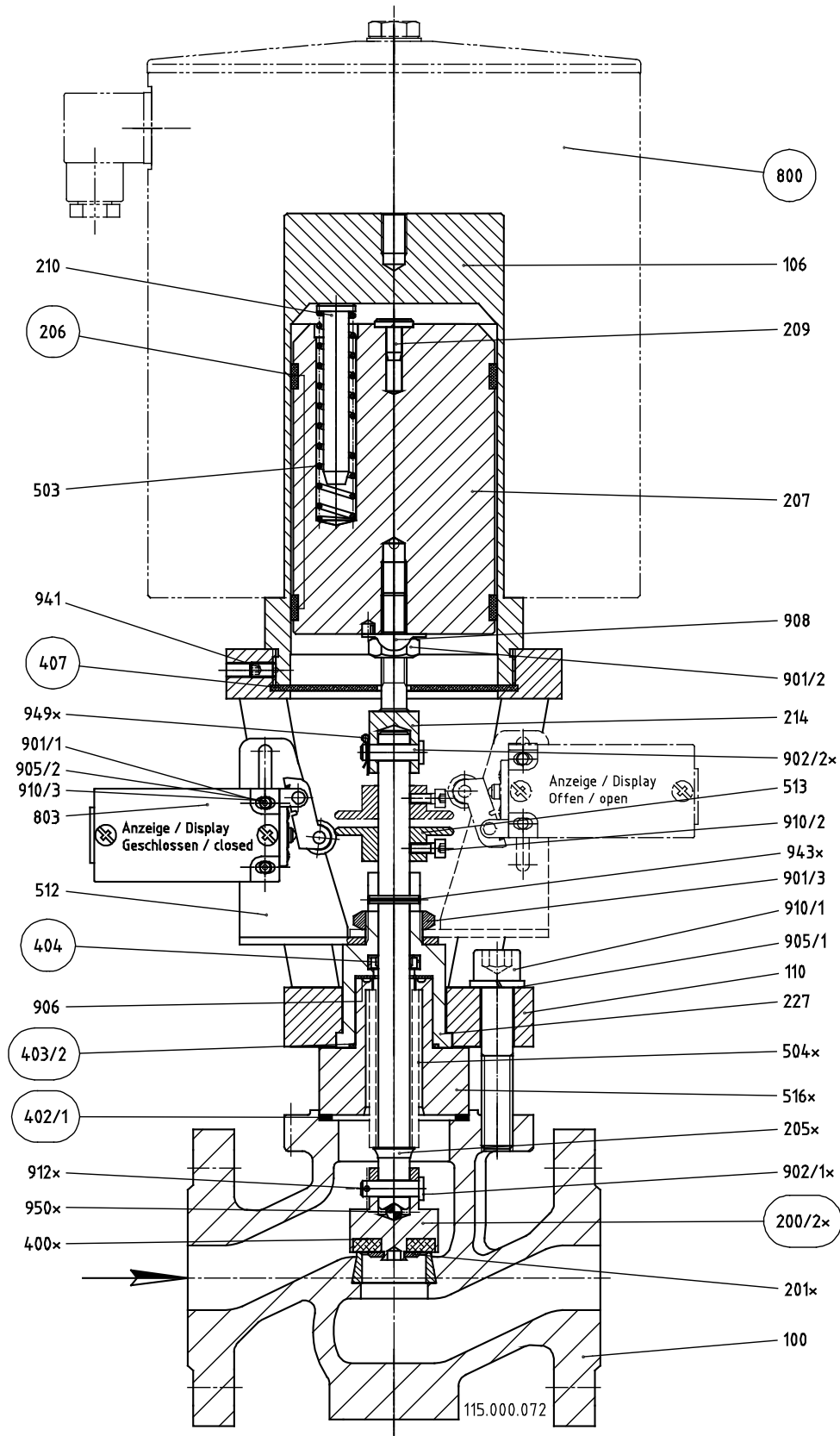

○ = Spare part kit

(...x) supplied as a complete unit

Fig. 4 5/10/25/40-EVF ...NÜ... (metal-of-metal sealing)

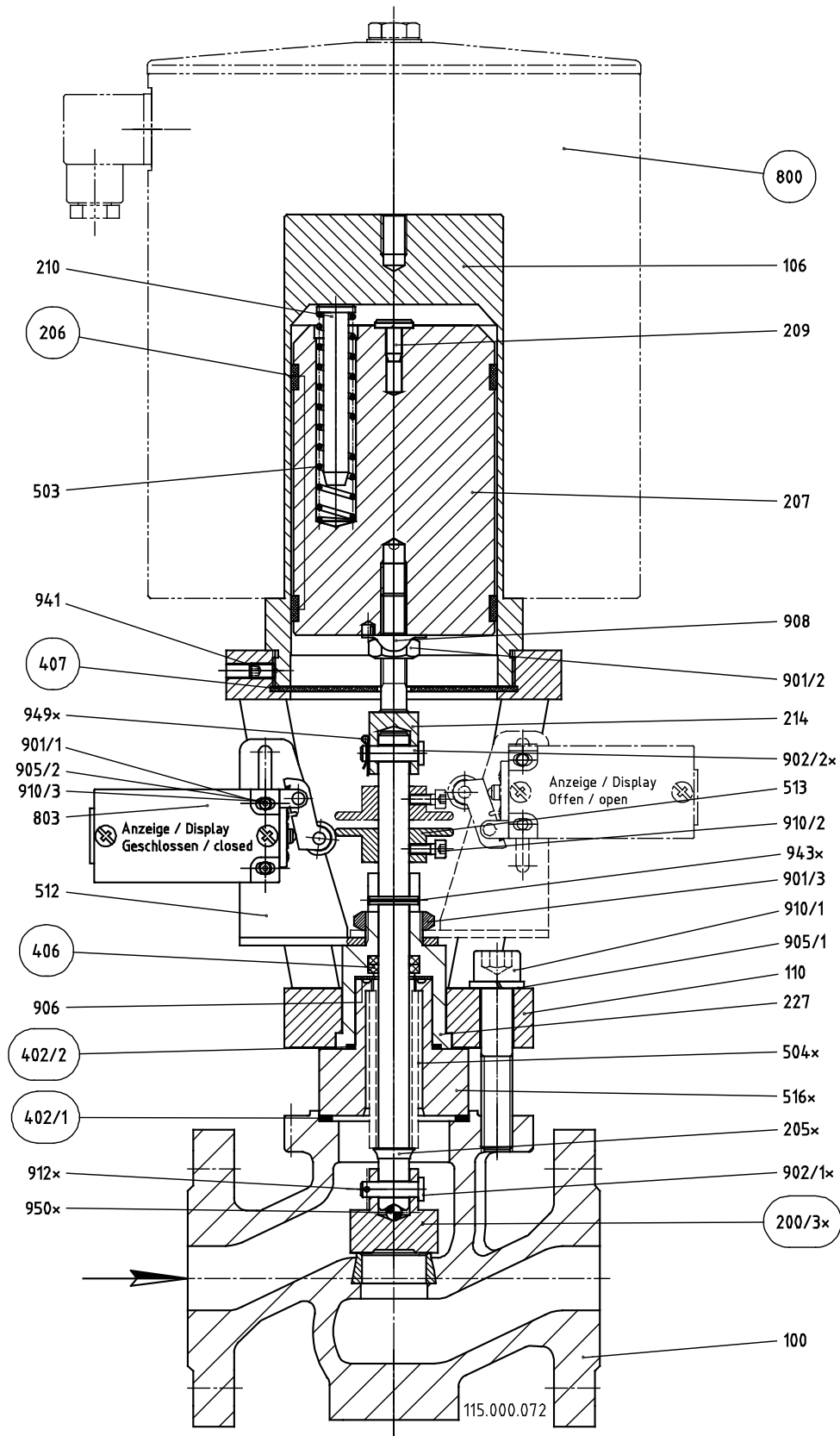

 = Spare part kit

(...x) supplied as a complete unit



Fig. 5 100-EVF...N... (DN25)

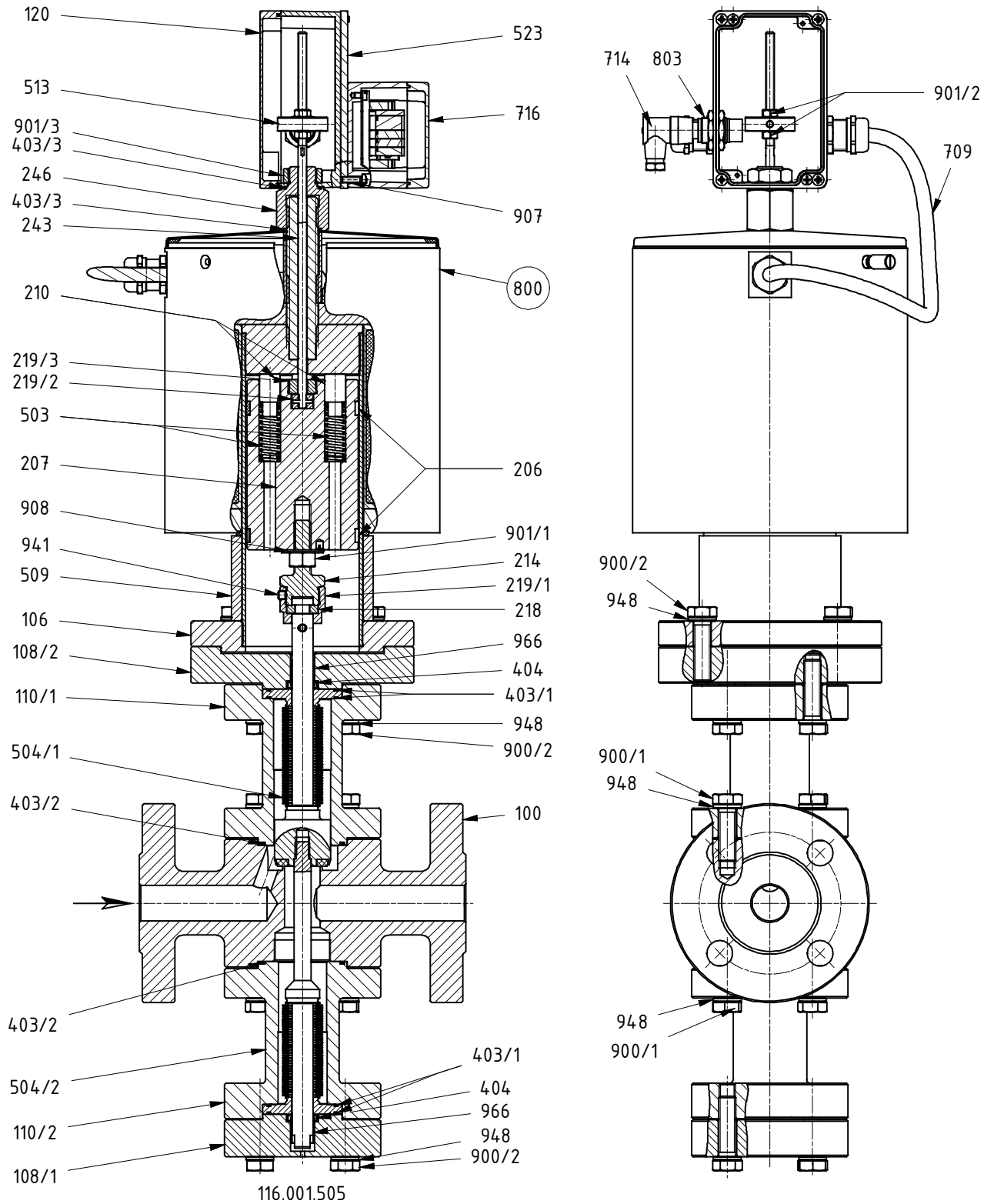
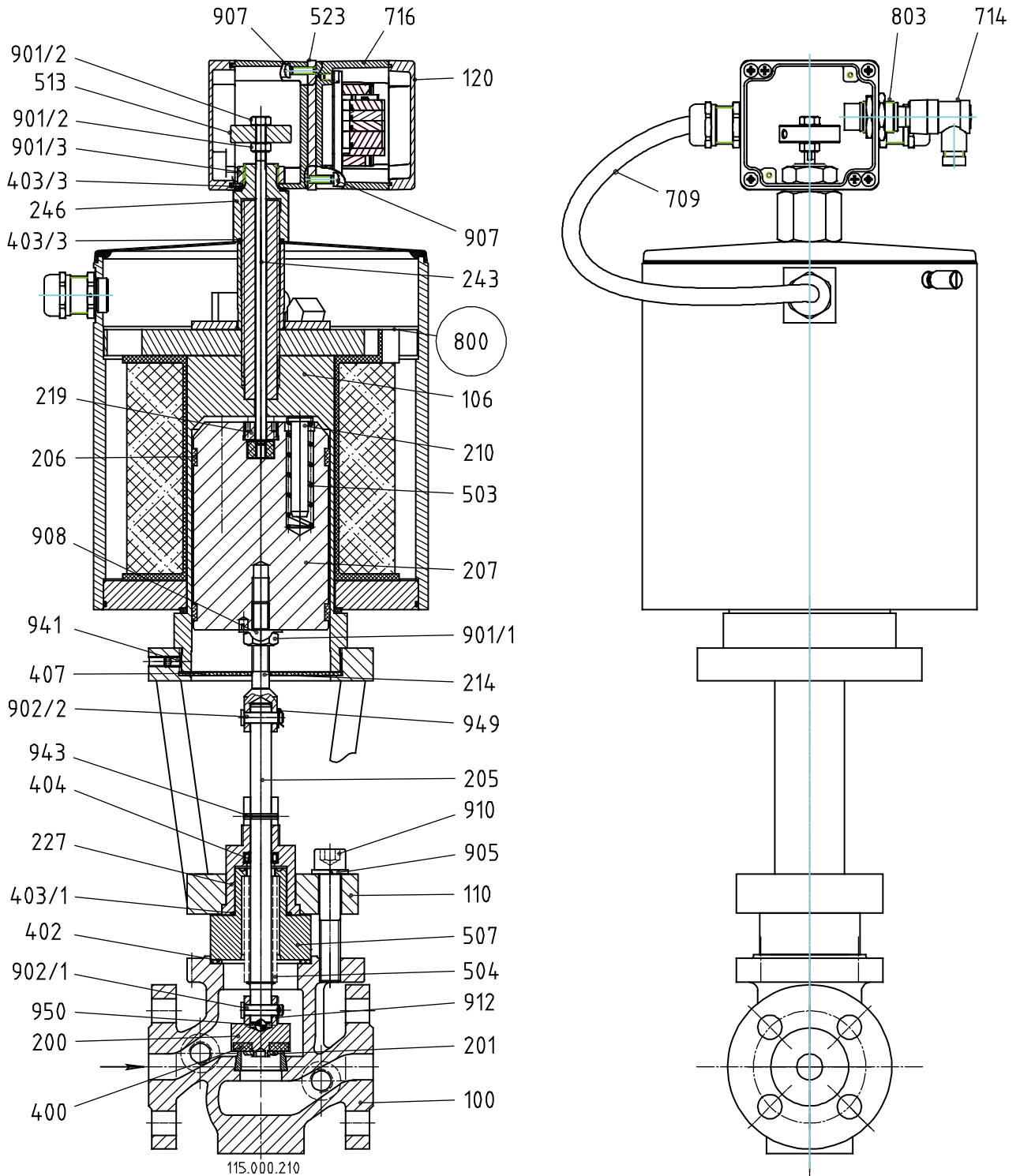

Fig. 6 40-EVF...NH... (DN15 – DN25)



= Spare part

11.2 View drawing

Fig. 1 100-EVF... (G1/2 – G3/4)

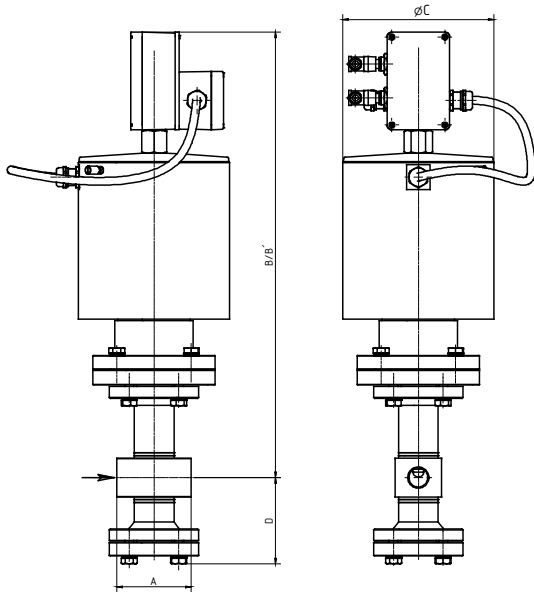

Fig. 5 100-EVF...N... (DN25)

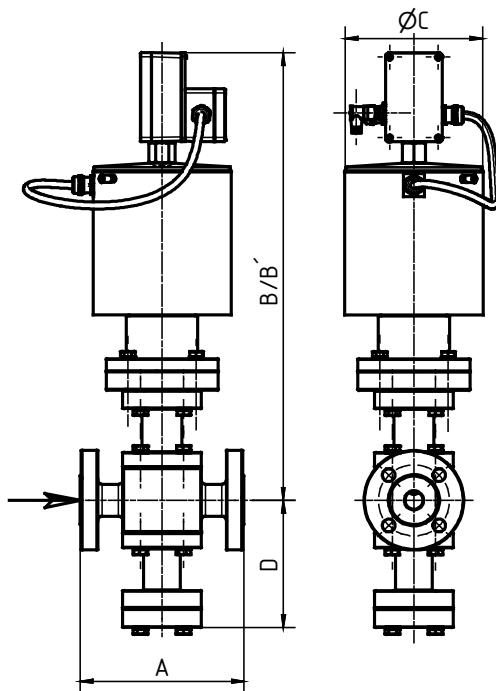

Fig. 2/3/4 5/10/25/40-EV(F)...N...(DN15 – DN50)

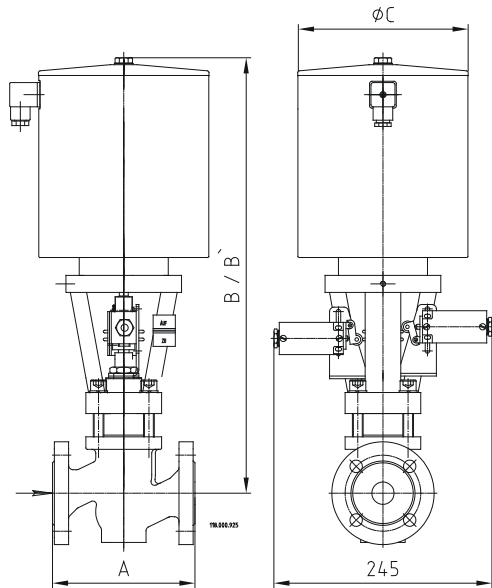
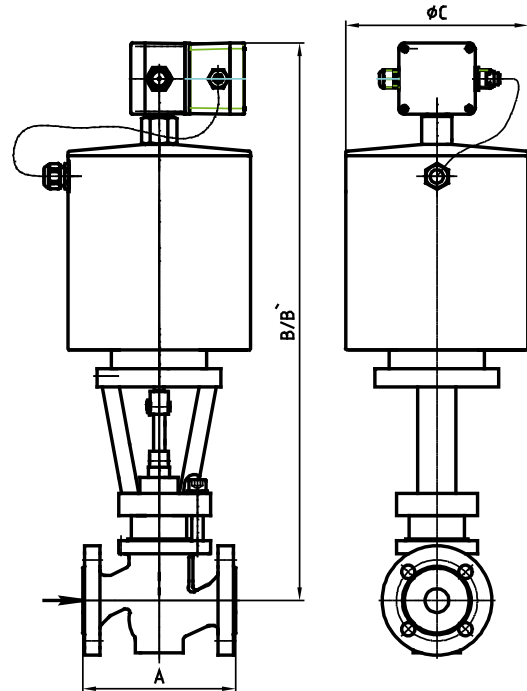

Fig. 6 40-EVF...NH... (DN15 – DN25)



### 11.3 List of parts

Pos./ Item	Stück/ Qty.	Benennung	Description
100	1	Ventilgehäuse	valve chamber
106	1	Gehäuseoberteil	upper part of housing
108/x	1	Gehäuseflansch	housing flange
110/x	1	Distanzstück	spacer
115	1	Dichtplatte	sealing board
120	1	Endschalter-Gehäuse	limit switch housing
200	1	Ventilteller	valve disk
200/1	1	Ventilteller	valve disk
200/2	1	Ventilteller	valve disk
200/3	1	Ventilteller	valve disk
201	1	Tellerscheibe	disc plate
205	1	Ventilspindel	valve spindle
206	2	Führungsring	guide ring
207	1	Magnetkern	solenoid core
209	1	Abwurfbolzen	discharge bolt
210	1/3/4	Federbolzen	spring bolt
212	1	Spindelführung	spindle guide
214	1	Ventilstift	valve pin
218	1	Zweiteiliger Ring	two-piece ring
219/x	1	Spindelmutter	spindle nut
227	1	Verdrehschutz	distort protection
243	1	Endschalterspindel	limit switch spindle
246	1	Verbindungsstück Endschalter	connction piece limit switch
249	1	Endschalter Konsolenhalter	limit switch console owner
400	1	Ventiltellerdichtung	valve disk sealing
402	1	Flachdichtung	gasket
402/1	1	Flachdichtung	gasket
402/2	1	Flachdichtung	gasket
403/1	1/2/4	O-Ring	o-ring
403/2	1/2	O-Ring	o-ring
403/3	2	O-Ring	o-ring
404	1/2	Lippenring	lip-ring
405	1	Abstreifring	scraper ring
406	2	Packung	packing
407	1	Staubschutzmembrane	dust guard membrane
503	1/3/4	Druckfeder	pressure spring
504	1	Faltenbalg	expansion bellows
504/1	1	Faltenbalg	expansion bellows
504/2	1	Faltenbalg	expansion bellows
507	1	Faltenbalgstück	bellow piece
509	1	Distanzring	distance ring
512	1/2	Endschalterkonsole	limit switch console
513	1/2	Endschalterbetätigung	switch actuator
516	1	Faltenbalggehäuse	housing of expansion bellows
523	1	Montagehalter	assembly bracket
709	1	Anschlußkabel	connecting cable
714	1/2	Leitungsdose	line socket
716	1	Klemmkasten	terminal box
800	1	Magnet-Antrieb	solenoid drive
803	1/2	Endschalter	limit switch
900/x	4/8/12	Sechskantschraube	hexagon head screw
901/1	1/2/4	Sechskantmutter	hexagon nut
901/2	1/2/4	Sechskantmutter	hexagon nut
901/3	1	Sechskantmutter	hexagon nut
902/1	1	Bolzen	bolt
902/2	1	Bolzen	bolt

Pos./ Item	Stück/ Qty.	Benennung	Description
905/1	4	Federring	lock washer
905/2	2/4	Federring	lock washer
906	1	Scheibe	washer
907	4	Senkschraube	countersunk bolt
908	1	Sicherungsblech	locking plate
910/1	4	Zylinderschraube	cylinder head screw
910/2	1/2	Zylinderschraube	cylinder head screw
910/3	2/4	Zylinderschraube	cylinder head screw
912	1	Splint	split-pin
941	1	Gewindestift	setscrew
943	1	Spannstift	spring dowel sleeve
948	12/20	Nordlockscheibe	nordlock washer
949	1	SL-Sicherung	SL-retainer
950	1	Kugel	Ball
966	2	DU-Buchse	DU-liner

Quantities of the individual components may vary depending on the version.

#### Wearing parts

Version	Fig.	Type	Spare parts
<b>Thread version</b>	Fig.1	100-EVF... ( G1/2 – G3/4)	Solenoid drive (800)
<b>Version</b>	<b>Fig.</b>	<b>Type</b>	<b>Spare parts</b>
<b>Flange version</b>	Fig.2	5/10/25/40- <b>EV</b> 5/7/10N	Spare part kit, Solenoid drive (800)
	Fig.3	5/10/25/40- <b>EVF</b> 5/7/10N	Spare part kit, Solenoid drive (800)
	Fig.4	5/10/25/40- <b>EVF</b> 5/7/10N	Spare part kit metal-of-metal sealing Solenoid drive (800)
	Fig.5	100-EVF...N... (DN25)	Solenoid drive (800)
	Fig.6	40-EVF...NH...(DN15 – DN25)	Solenoid drive (800)

**Dimension with standard solenoid drive**

Connection G	Dimension	1/2 (5)	3/4 (7)	1 (10)	1 1/4 (12)	1 1/2 (15)	2 (20)
Installation length	A	95	95	-	-	-	-
100-EVF....	B	572	572	-	-	-	-
	B'	722	722	-	-	-	-
	ØC	194	194	-	-	-	-
	D	111	111	-	-	-	-

Flange DN	Dimension	15 (5N)	20 (7N)	25 (10N)	32 (12N)	40 (15N)	50 (20N)
Installation length	A (*)	130	150	160	180	200	230
Flange ANSI	Dimension	1/2"	3/4"	1"	1 1/4"	1 1/2"	2"
5-EV..NÜ..92/93	B	447	447	447	478	478	488
	B'	565	565	578	628	628	638
	ØC	153	153	153	194	194	194
10-EV..NÜ..92/93	B	447	447	470	478	478	-
	B'	578	578	620	628	628	-
	ØC	153	153	194	194	194	-
25-EV..NÜ..92/93	B	447	447	470	478	478	-
	B'	578	578	620	628	628	-
	ØC	153	153	194	194	194	-
40-EV..NÜ..92/93	B	470	470	470	511	-	-
	B'	620	620	620	691	-	-
	ØC	194	194	194	230	-	-
5-EVF..NÜ..92/93	B	466	466	466	498	498	508
	B'	583	583	597	648	648	658
	ØC	153	153	153	194	194	194
10-EVF..NÜ..92/93	B	466	466	490	498	498	-
	B'	597	597	640	648	648	-
	ØC	153	153	194	194	194	-
25-EVF..NÜ..92/93	B	466	466	490	498	498	-
	B'	597	597	640	648	648	-
	ØC	153	153	194	194	194	-
40-EVF..NÜ..92/93	B	490	490	490	531	-	-
	B'	640	640	640	711	-	-
	ØC	194	194	194	230	-	-
40-EVF...NH.Ü....	B	583	583	583	-	-	-
	B'	740	740	740	-	-	-
	ØC	194	194	194	-	-	-

Flange DN	Dimension	15 (5N)	20 (7N)	25 (10N)	32 (12N)	40 (15N)	50 (20N)
Flange ANSI	Dimension	1/2	3/4	1	1 1/4	1 1/2	2
Installation length	A	-	-	230(#)	-	-	-
100-EVF...N..	B	-	-	629	-	-	-
	B'	-	-	779	-	-	-
	ØC	-	-	194	-	-	-
	D	-	-	189	-	-	-

(#) VG-chamber PN100

A = Dimension at DIN (resp. flanges ANSI and dimension DIN or flanges and dimension DIN)

(\*) = Dimension at ANSI (see data sheet on our website armature installation length 225.100.026)

B' = Dimension for removing the solenoid drive

## 12.0 Declaration of Conformity

UNI-Geräte E. Mangelmann  
Elektrotechnische Fabrik GmbH  
Holtumsweg 13  
D – 47649 Weeze



### EU Konformitätserklärung Declaration of Conformity

Produkt <i>Product</i>	Sicherheitsabsperrentil <i>Safety shut-off valve</i>
Handelsbezeichnung <i>Trade Mark</i>	Magnetventil <i>Solenoid Valve</i>
Baureihe <i>Series</i>	5-EV(F)...N... 100-EV(F)...N...
Nennweiten <i>Sizes</i>	DN 15 – DN 50 ; G1/2, G3/4
Fluidgruppe <i>Fluide group</i>	Brennbare Flüssigkeiten FL. Gr.1 <i>Flammable Liquids, FL. Gr. 1</i>
EU-Richtlinien <i>EC-Directives</i>	2014/68/EU Druckgeräterichtlinie / <i>Pressure Equipment Directive</i>
Konformitätsbewertungsverfahren <i>Conformity Assessment Procedure</i>	Modul H 2014/68/EU
Angewandte technische Spezifikation <i>Applied Technical Specification</i>	DIN EN 264 AD 2000, EN 12516, EN 12266
EG Baumusterprüfung <i>EC-Type Examination</i>	DIN EN 264 TÜV Rheinland, Köln <sup>2)</sup>
Überwachungsverfahren <i>Surveillance Procedure</i>	CE-0062-PED-H-UGM 001-20-DEU 2014/68/EU Modul H Bureau Veritas Services SAS 8 Cours du Triangle 92800 PUTEAUX – LA DEFENSE Zertifizierungsstelle / <i>Notified Body 0062</i>
Kennzeichnung <i>Marking</i>	CE - 0062 <sup>1)</sup>

Das Unternehmen UNI Geräte E. Mangelmann Elektrotechnische Fabrik GmbH erklärt in alleiniger Verantwortung, dass die o.a. Baureihe die grundsätzlichen Anforderungen der aufgeführten Richtlinien und Normen erfüllt.

*UNI Geräte E. Mangelmann Elektrotechnische Fabrik GmbH confirms under the sole responsibility of the manufacturer, that the basic requirements of the above specified directives and standards are fulfilled.*

**Weeze, 14.05.2020**

---

**Geschäftsführer**  
Norbert Schneider  
Managing Director

<sup>1)</sup> PS\*DN < 2000, siehe Diagramm 8, fallen unter Artikel 4 Abs. 3 der 2014/68/EU  
*PS\*DN < 2000, see diagram 8, are mentioned in article 4 § 3 of 2014/68/EU*

<sup>2)</sup> Gilt nur für mit x gekennzeichnete Ventile siehe Betriebsanleitung  
*Only for valves marked with x, refer to the operating instructions*