

Operating and mounting manual

Double safety shut off valve

gas – solenoid valve

VX

Contents

- 1.0 General Remarks**
 - 1.1 Valve data
 - 1.2 Application

- 2.0 Danger Notices**
 - 2.1 Safety terms
 - 2.2 Safety notice
 - 2.3 Qualified staff
 - 2.4 Unauthorized modification and spare part production
 - 2.5 Unauthorized operation
 - 2.6 Safety information for the use in explosion-prone areas guideline 2014/34/EU

- 3.0 Handling**
 - 3.1 Transport
 - 3.2 Storage
 - 3.3 Handling before mounting

- 4.0 Product Description**
 - 4.1 Function
 - 4.2 Technical data
 - 4.3 Test volume between V1 and V2
 - 4.4 Marking

- 5.0 Installation**
 - 5.1 Warning of dangers during installation, operation and maintenance
 - 5.2 Installation

- 6.0 Operation**
 - 6.1 Commissioning
 - 6.2 Shutting down
 - 6.3 Putting back into operating
 - 6.4 Maintenance interval

- 7.0 Troubleshooting**
 - 7.1 Detection of defects
 - 7.2 Troubleshooting plan

- 8.0 De-installation of valve unit**
 - 8.1 Visual control, de-installation of valve unit V1, or respectively, valve unit V2

- 9.0 Warranty**

- 10.0 Explanations on Codes and Directives**

- 11.0 Drawing**
 - 11.1 Sectional drawing
 - 11.2 List of parts

- 12.0 Declaration of Conformity**

1.0 General Remarks

This operating manual includes instructions to assemble and operate the valve in the prescribed and safe way. **Additionally, the adequate operating instructions of each special solenoid drive must be considered.**

Series MA...

220.100.159

If any difficulties appear that can not be solved by means of the operating manual, further information may be demanded from the manufacturer.

This operating manual is in accordance with the relevant valid EN safety standards and the valid prescriptions and rules of the Federal Republic of Germany.

If the solenoids are used abroad of the FRG, the operator and/or the person who is responsible for the plant concept must take care that the valid national rules are met. The manufacturer reserves the right of any technical change and improvement. The use of these operating instructions suppose the qualification of the user according to paragraph 2.3 "qualified staff".

The operating staff must be trained in accordance with the operating instructions. The operating manual must always be available at the location where used.

1.1 Valve data

Manufacturer:

UNI Geräte E. Mangelmann
Elektrotechnische Fabrik GmbH
Holtumsweg 13
D-47652 Weeze
Telefon: +49 (0) 2837/9134-0
Fax: +49 (0) 2837/1444
E-Mail: info@uni-geraete.de
Homepage: www.uni-geraete.de

Designation

Directly functioning, currentless closed, spring double safety shut off valve with solenoid drives.

Type test acc. to: EU/2016/426 Prod. Id. CE-0085BU0011
DIN EN 161 Kl. A, Gr. 2

Working pressure: VX...05 0 - 0,5 bar
VX...5 0 - 5bar

Medium temperature: -20°C to + 60°C

Ambient temperature: -20°C to + 60°C

Fitting position: arbitrary

Switching cycles: see operating instructions solenoid drive

Flange connection measures acc. to: DIN EN 1092-2 / ANSI

Flange DN ANSI	PN	65 (25N) 2 1/2"	80 (30N) 3"	100 4"	150 6"	Test pressure (*) PT
VX...05	16	X	X	-	-	PT 6
VX...05	10	-	-	X	X	PT 6
VX...5	16	X	X	-	-	PT 10
VX...5	10	-	-	X	-	PT 10

(*) Test pressure to perform leakage test "NO FUNCTION TEST"

X Type test acc. to EU/2016/426, O Acceptance test certificate 3.2 possible, - not available,

Voltage: VDC 12 – 440 (–15% bis +10%)
VAC 24 – 500 (–15% bis +10%)

Protection type: IP54 or IP65

Frequency	40 – 60 Hz
Power	10 – 4000W

Details to the electrical data can be found on the type sign and the adequate operating instructions of the solenoid valves.

1.2 Application

The UNI Geräte Gas – Solenoid valves VX are used as automatic double safety shut-off valves for protection, limitation, shut-off and release of gas and air supply at main stops of in front of gas burners. e.g. to DIN EN 746-2, DIN EN 12952-8.

The valves are suitable for gases of the 1st, 2nd and 3rd gas families to G260 and for neutral gases and as a variant with material design for aggressive gases such as e.g. biogas, sewage plant gas or dump gas to G262.

If used in other cases, the operator must carefully check if construction/design of valve, accessories and materials are suitable for the new application. The range of application is subject to the responsibility of the plant planner. The service life of the valve is 20 years.

2.0 Danger Notices

2.1 Safety terms

The signal terms DANGER, CAUTION und NOTICE are used in this operating manual in case of notices concerning special dangers or for unusual information requiring a special marking.



DANGER! means that in case of non-observance there is danger to life and/or considerable damage.



CAUTION! means that in case of non-observance there is danger of injury and/or damage.



NOTICE! means that attention is drawn to technical correlations/connections.

Observance of other, not especially marked notices concerning transport, assembly, operation and maintenance and other data (in the operation instructions, product documentation and at the unit itself) is also essential, in order to avoid disturbances that might affect direct or indirect damage to property or injury to persons.

2.2 Safety notice

Non observance of safety instructions can lead to loss of any claim for damages.

Non observance can lead to the following mentioned dangers:

- Failure of important functions of the valve/plant
- Endangering of persons by electrical or mechanical influences.
- Protection against accidental contact for moving parts may not be removed as long as the valve is in operation.
- Leakage of dangerous media (e.g. explosive, toxic, hot) must be removed in the way that there is no danger for persons or environment. Laws and regulations must be observed.

2.3 Qualified staff

These are persons who are familiar with erection, assembly, starting, operation and maintenance of the product and who have special qualifications acc. to their activities and functions, e.g.:

- Instruction and obligation to carry out and meet all regional and in-house orders and requirements.
- Education or instruction according to the safety engineering standards in use and maintenance of adequate safety and working protection equipment.
- Training in first aid.

2.4 Unauthorized modification and spare part production

Modification or changes of the valve are only allowed after agreement of the manufacturer. Original drawings and accessories authorized by the manufacturer are for safety purposes. The use of other parts or unauthorized changes at the valve by third persons may cancel and abolish the manufacturer's liability for resulting consequences.

2.5 Unauthorized operation

Operational reliability of the delivered valve is only guaranteed in case of determined use in accordance to paragraph 1 of the operating manual. **The application limits mentioned on the type sign may on no account be exceeded.**

2.6 Safety information for the use in explosion-prone areas guideline 2014/34/EU

- The temperature of the medium must not exceed the respective temperature class, and respectively, the respective maximum permitted medium temperature as per operation guideline.
- If the valve is heated (e.g. heating jacket), care must be taken, that the specified temperature class is kept in the time.
- The valve must be connected to the ground.
In the case most simple this can be realized via pipe screws by means of tooth disc.
Otherwise the connection to the ground must be implemented by other measures e.g. cable links.
- Control valves, electrical and electrical/mechanical drives as well as sensors must undergo a separate conformity check as per ATEX. In doing so the respective safety and explosion protection information in the operation instructions are to taken into special consideration.
- Any modifications whatsoever to the valve are not allowed. The ATEX approval is void with immediate effect if the valve is modified without prior authorisation (even including painting).
- UNI-Geräte GmbH must be consulted before any modifications are made

Furthermore we point out the guideline ATEX 118a, which include the minimum regulations for the improvement of the health-related situation and the safety of the employees, who might be jeopardized by an explosive atmosphere.

3.0 Handling

3.1 Transport

For any transport works, the generally recognised technical rules and standards as well as rules for prevention of accidents must be observed.

In case of transport, storage and stopping, the flange protection caps must be mounted at both valve flanges.

The goods to be transported must be carefully treated. During transport, the valve must be protected against strokes, impacts or vibration. The coat of lacquer may not be damaged. Transport temperature is -20°C up to $+60^{\circ}\text{C}$.

Never transport the valve at screwed cable glands, appliance plugs or add-on units. The valve can be transported at ring nuts, flange borings or by means of a belt under the solenoid drive.

Transport the valve in a case or on a pallet with smooth base and put it softly on plain floor. **Never put the valve on limit switch box.**

The goods must be checked on completeness and transport damage. See also section 9.0

3.2 Storage

If the valve is not installed immediately after delivery, it must be stored properly.

- Storage temperature -20°C up to $+60^{\circ}\text{C}$, dry and clean.
- The lacquer protects against corrosion in neutral dry atmosphere. Do not damage colour.

- In humid rooms, a drying agent or a heating resp. is necessary because of condensation of water.

Requirements according to DIN 7716 (products made of caoutchouc and rubber) must be met.

3.3 Handling before mounting

- In case of valve with protection caps, they must be removed before being mounted!
- Protect against atmospheric influences such as humidity (otherwise use drying agent).
- Appropriate treatment protects against damage.

4.0 Product Description

The UNI-Geräte gas – solenoid valve VX is a (at TRD 412) directly controlled, currentless closed, double safety shut-off -valve acc. to DIN EN 161 with solenoid drive.



NOTICE!

The valve units 1 (V1) and/or 2 (V2) must not be interchanged when they are exchanged, since otherwise the function of the double solenoid valve VX... can no longer be guaranteed.

Sectional drawing 11.1 Fig. 1 - 2 shows the valve construction.

4.1 Function

By switching on the solenoid drive (800) V1 resp. V2 individually (see sectional drawing 11.1), the solenoid core (207) is drawn against the upper part (106). The pressure spring (503) is pressed and the balance piston (220) releases the valve cross section. The valve is open.

The valve close by switching off, interruption or failure of power energy to solenoid drive. Due to press of the pressure spring (503) the balance piston (220) closes. The valve is closed at 15% of nominal voltage.

4.2 Technical data

Opening times: < 1s

Closing times: < 1s

Solenoid –drive types MA...

Flange DN	65	80	100	150
Flange ANSI	2 1/2"	3"	4"	6"
VX....05	MA40 72/8W	MA40 110/11W	MA50 147/15W	MA60 500/70W
VX....5	MA40 110/11W	MA40 200/20W	MA50 190/19W	-

Max. valve loading by pipe power at DIN EN 161

The indicated moments may not work longer than 10s.

DN		8	10	15	20	25	32	40	50	65	80	100	125	≥150
Torsion	Nm	80	35	50	86	125	160	200	250 ¹⁾	325 ¹⁾	400 ¹⁾	-	-	-
Bending	Nm	35	70	105	225	340	475	610	1100	1600	2400	5000	6000	7600

¹⁾ Not valid in case of valves with flanges

Starting torque, pipe screws greased

DN		8	10	15	20	25	32	40	50	65	80	100	125	≥150
Torque	Nm	20	30	30	30	30	50	50	50	50	50	80	160	160

Starting torque, product screws and nuts greased

Screw		M6	M8	M10	M12	M16	M20	M24
Torque	Nm	5	11	22	39	70	110	150

4.3 Test volume between V1 and V2

Volume between V1 and V2 for leak testing systems

Type	Volume dm ³	Type	Volume dm ³
VX 65	0,48	VX 100	1,5
VX 80	0,81	VX 150	4,7

4.4 Marking

The type sign on the solenoid drive has the following information:

- Fabricator
- Valve type, nominal width, pressure and temperature indication, fitting position
- Year of construction/ production no.
- Product ID No. to EU/2016/426
- Valve class and valve group acc. to DIN EN 161
- CE-sign and no. of relevant location to 2014/68/EU
- Fluid group and test pressure PT to 2014/68/EU
- Solenoid drive type
- Electr. performance
- Voltage
- Frequency
- Protection type

Refer also to section 10.0.

5.0 Installation

5.1 Warning of dangers during installation, operation and maintenance



DANGER!

Safe operation of the valve can only be guaranteed if it is installed, commissioned and maintained by qualified personnel (see point 2.3 "Qualified staff") correctly and in observance of the warnings in this operating manual. Apart from that, the operation safety order and the qualified use of tools and protection equipment must be guaranteed. The operating instructions for the valve must be observed during all work on or with the valve. Failure to observe these instructions may result in injury or in damage to the valve or other installations.

When the valve is used as a final sealing element, a safety precaution e.g. blanking disc, blind flange, etc., in accordance with the code of practice of the German Technical and Scientific Association for Gas and Water (DVGW) is recommended during all repair work.

5.2 Installation

Apart from the general installation guidelines, the following points should be observed:



NOTICE!

- Remove the flange covers.
- The inside of the valve and the pipeline must be free from foreign particles.
- Observe the installation position in relation to the flow direction, see markings on the valve.
- Centre gaskets between the flanges.
- The connecting flanges must be aligned.
- Ensure that none of the components is strained during installation.
- The valve must not be used as a fixed point; it is supported by the pipework system.
- Protect valves from soiling, particularly during construction work.
- Thermal expansion of the pipework must be equalized using compensators.

In accordance with DIN EN 13611 and DIN EN 161, a dirt trap must be installed upline of any safety shut-off device. The mesh size of the screen must be smaller than 1.5 mm and not allow a test mandrel of 1 mm diameter to pass. The dirt trap must be installed not too far upline of the first valve. The UNI-Geräte dirt traps of the SFR Series are approved for use together with the gas solenoid valves and gas pneumatic valves in accordance with EU/2016/426.



NOTICE!

Please observe the solenoid drive operating instructions MA.

6.0 Operation



DANGER!

Before commissioning a new installation or before starting up an installation again after repairs or modifications, ensure:

- The proper completion of all installation and assembly work!
- Commissioning only by “qualified staff” (see point 2.3).
- Installation or repair of existing guards and protection equipment.

6.1 Commissioning

- Before commissioning, check the data on material, pressure, temperature and flow direction with the layout plan of the pipework system.
- Depending on the field of application, the local regulations have to be observed, e.g. the operation safety order.
- Residues in the pipework and the valve (dirt, weld beads, etc.) will inevitably result in leaks.
- Leakage inspection of the installed valve.

6.2 Shutting down

- Depending on the field of application, the local regulations have to be observed, e.g. the operation safety order.

6.3 Putting back into operation

When putting a valve back into operation, ensure that all the necessary steps described in section 5.2 (Installation) and section 6.1 (Commissioning) are repeated.

6.4 Maintenance interval

Solenoid valve have to checked at regular intervals for proper function and internal leak thightness. The intervals for regular inspections have to be defined by the operator according to the operating conditions. UNI-Geräte recommends an internal visual inspection once a year and a overhaul of the valve after 2 years or after the switching cycles at DIN EN 161.

UNI-Geräte prescribes the following maintenance intervals for valves with SIL requirements:

The safety requirements with regard to the maintenance intervals to be adhered are described in the **SIL manual** of the type series and must be complied with.

7.0 Troubleshooting

7.1 Detection of defects



DANGER!

Be sure to observe the safety instructions during troubleshooting.

If the malfunctions cannot be remedied using the following “**Troubleshooting plan (7.2)**” please contact the manufacturer.

In the event of faults in the function or operating behaviour of the valve, check whether the installation work was carried out and completed as described in this operating manual.

Depending on the field of application, the operation safety order must be observed.

Check the data on material, pressure, temperature, voltage and flow direction with the layout plan of the pipework system. In addition, check whether the operating conditions correspond to the technical data in the data sheet or on the rating plate.

7.2 Troubleshooting plan

Malfunction	Possible causes	Remedy
No flow	Valve does not open	Switch on solenoid drive (800) Check operating voltage
	Working pressure too high	Compare working pressure with the data on the rating plate
	Flange covers were not removed	Remove flange covers
Low flow rate	Contaminated strainer	Filter clean/exchange
	Clogging in the pipework system	Check pipework system
Valve leaking at seat, no internal tightness	Valve seat gasket (400) or valve seat (100) damaged by external particles	Perform visual control as per chapter 8.1
No external tightness	O-ring (403/2) damaged	Perform visual control as per chapter 8.1
	Flange sealing not installed in centre	Take care of centre position of the flange sealing
	Screws unilaterally tightened	Equally tighten screws crosswise
Valve does not close	Connected voltage too high	Check whether there is residual voltage, see section 4.1
	External matter in valve	Check pipework. Clean valve
Flange fracture (valve/pipework)	Screws not tightened uniformly, mating flanges not aligned	Align pipework. Install new valve



NOTICE!

Observe section 10.0 before all installation and repair work!

Observe section 6.4 when putting the valve back into operation!

8.0 Dismantling of the Valve

In addition to the general installation guidelines and the operation safety order, the following points must also be observed:



DANGER!

- Depressurised pipework system
- Cooled medium
- Emptied installation
- Vent pipework systems containing corrosive, inflammable, aggressive or toxic media
- Have dismantling work carried out only by qualified staff (see point 2.3)

8.1 Safety check, de-installation of valve unit V1, or respectively V2

Stop the valve as per chapter 6.2.

Unscrew protective cap (505) and remove including the O-ring (403/6).

Stop the solenoid drive and de-install it as per operating instruction of the solenoid drive MA (220.100.159).



DANGER!

In case of permanent operation the solenoid drive may be hot, danger of burning!



NOTE!

The spare part kit 3 must be ordered or be on stock before executing the visual control, or respectively exchange of valve unit V1 and/or V2.
In the spare parts kit 3 inter alia, the mounting aid.

Remove yellow ad cap (531) for the optical position indicator with long-nosed pliers (fig. 1).

From the mounting aid (consisting of: knurled head screw with knurled washer, see fig. 2), screw the knurled head screw



Fig. 1

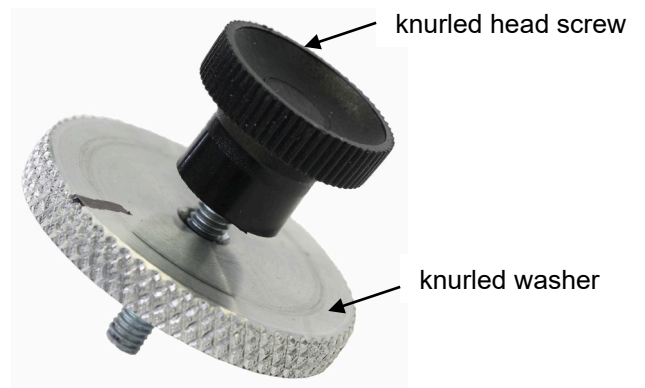

Fig.2

into the indication pin (see fig. 3),
of the optical position indicator.

Screw the knurled washer onto the upper part
of the housing (106) (fig. 4).

After that further unscrew knurled washer by
approximately three turns clockwise (fig. 5),

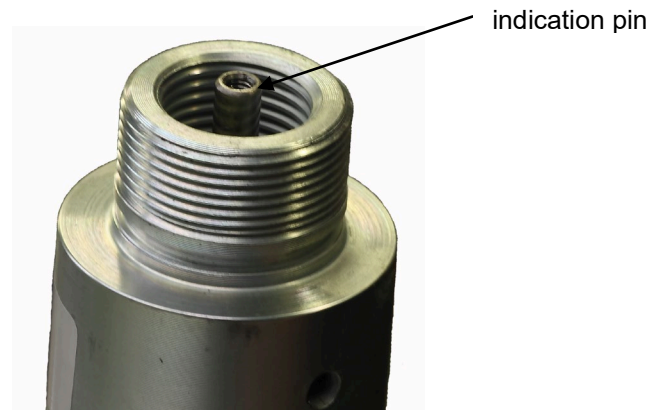

Fig. 3

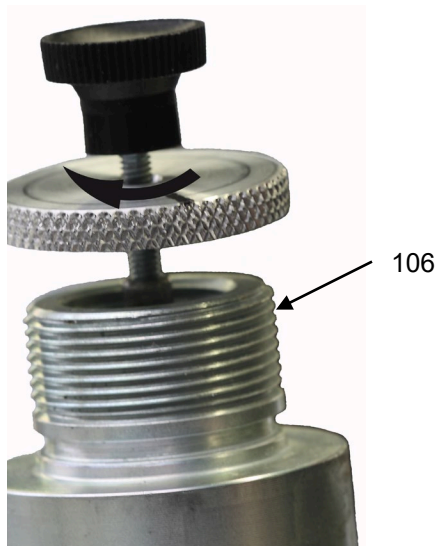

Fig. 4

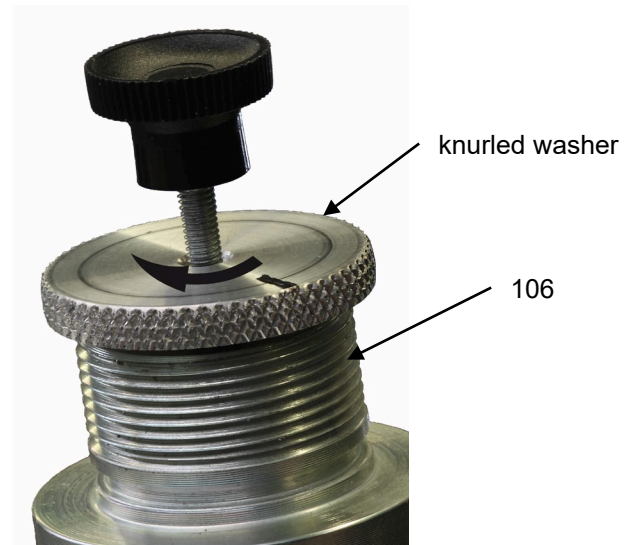

Fig. 5

so that the balance piston (220) comes off the valve seat.

Loosen and remove the hex. head screw (900).

Now lift the complete valve unit V1 or V2 out of the valve housing (100) and put it onto an even and clean surface.



ATTENTION!

Under no conditions screw the installation support out of the indication pin of the optical position indicator.

In case of a visual check the following points must be checked:

1. Damages at the valve seat (100).
2. Damages at the sealing elements (valve disk sealing (400))

In case of damages at the valve seat exchange the complete solenoid valve.

In case of damages at the sealing elements the valve unit V1 (spare part kit 1) is to be used.

In case of damages at the sealing elements the valve unit V2 (spare part kit 2) is to be used.



DANGER!

Valve unit is under spring tension!

Under no conditions remove the installation support out of the indication pin of the optical position indicator.



NOTE!

In case of the visual check the O-rings (403/2) (included in spare part kit 3) must always be exchanged.

Assemble the valve in the reverse order.



ATTENTION!

Install the wear and tear parts correctly and do not damage them during installation.

Check the valve as per DIN EN 12266 and DIN EN 161 for internal and external leakage and perform a function test.

9.0 Warranty

Scope and period of the warranty is specified in the edition of the "General Terms of Business of the UNI-Geräte E. Mangelmann Elektrotechnische Fabrik GmbH" valid at the time of delivery or else in the purchase agreement.

We warranty that the valve is free from faults in line with the state of the art and for the confirmed field of application.

No warranty claims will be accepted for damage resulting from improper use or failure to observe these operating and installation instructions, the statutory accident prevention regulations, the EN, DIN and VDE standards and other codes and regulations.

Warranty claims will also not be accepted for damage occurring during operation due to operating conditions deviating from those specified in the data sheet or in other agreements.

Justified complaints will be remedied by reworking by us or specialist companies authorized by us.

Claims going beyond the scope of the warranty will not be accepted. The customer shall have no right to the supply of a replacement valve.

Maintenance work, installation of parts from other manufacturers, any modifications to the design and natural wear are not covered by the warranty.

Transport damage must be reported not to us but **without delay** to your responsible goods handling company, the railway company or the shipping agent as otherwise all claims for damages against these companies will be voided.

10.0 Explanations on Codes and Directives

The Commission of the European Union has laid down common directives for the free trading of goods within the Union specifying minimum requirements for safety and health protection. The CE symbol confirms that products comply with the EU directives, i.e. in conformity with the relevant, in particular harmonised standards. Directives 2009/142/EG and 2014/68/EU are of relevance for the gas solenoid valve (mechanical part).

Notes on Regulation EU/2016/426 (Gas Appliances Regulation, GAR):

The valves have been developed, manufactured and tested in accordance with harmonised standard DIN EN 161, DIN EN 13611 and comply with the relevant requirements of the Union regulation EU/2016/426. Unless otherwise stated separately, this has been confirmed by a type test.

Notes on Directive 2014/68/EU (Pressure Equipment Directive, DGRL):

It has been confirmed that the quality assurance in design control, manufacture and final acceptance of the manufacturer, UNI-Geräte E. Mangelmann Elektrotechnische Fabrik GmbH, satisfy the requirements of 2014/68/EU Article 14 Module H. The gas solenoid valves comply with the fundamental requirements of Directive 2014/68/EU. Valves in according to Article 1 Paragraph 2,f,v or Article 4 paragraph 3 are not allowed to have the CE Mark in according to Article 18.

Note concerning ex-guideline 2014/34/EU (explosion guideline ATEX):

The product is not subject to guideline 214/34/EU, since due to the loads occurring during practical operation, there is no effective source of ignition even in case of an error case to be assumed. This also applies to spring loaded components in gas-filled rooms. In case of electric drives, sensors or other electric components the application as per 2014/34/EU is to be checked separately.

11.0 Drawing

11.1 Fig.1 sectional drawing VX...

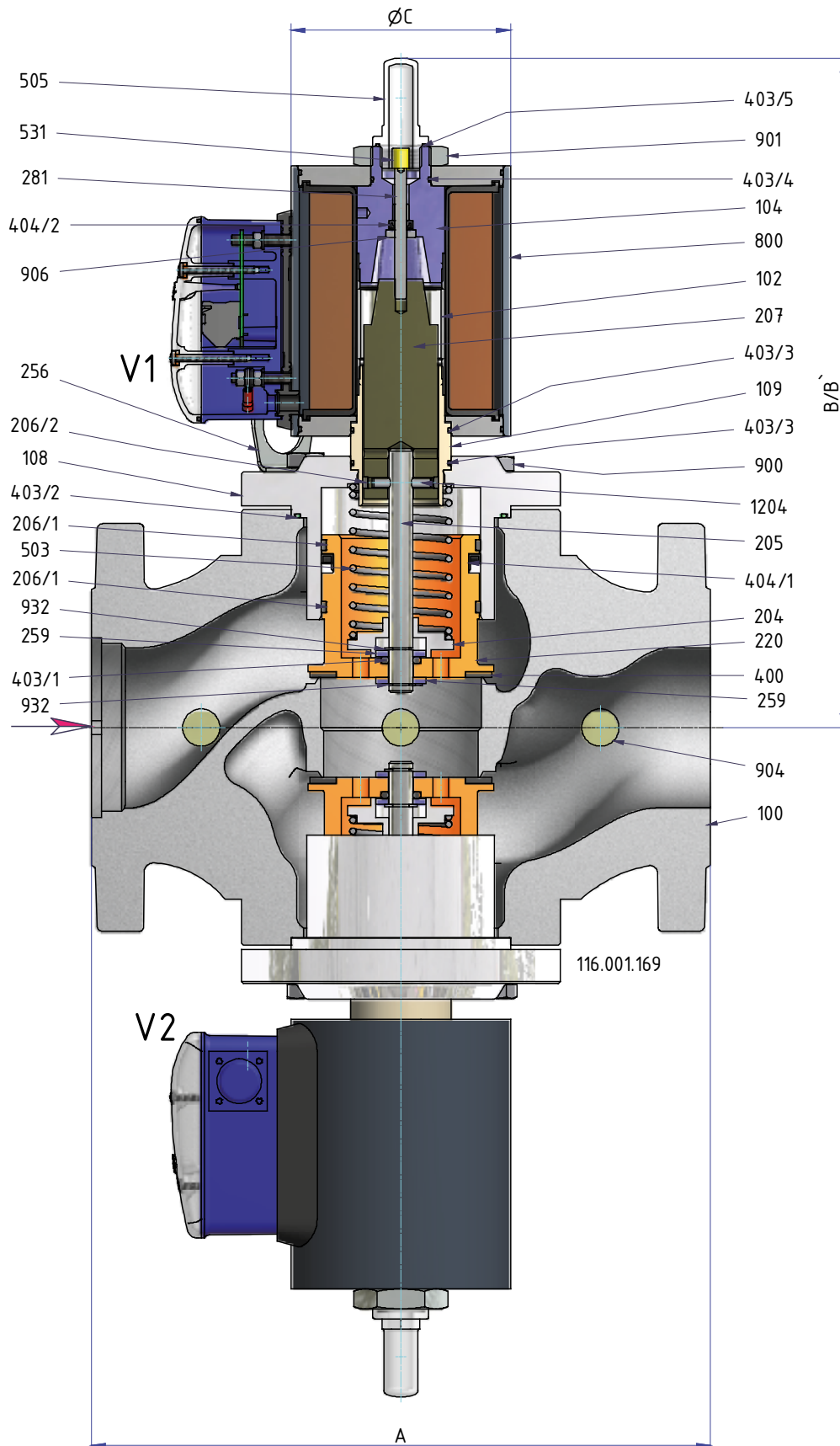
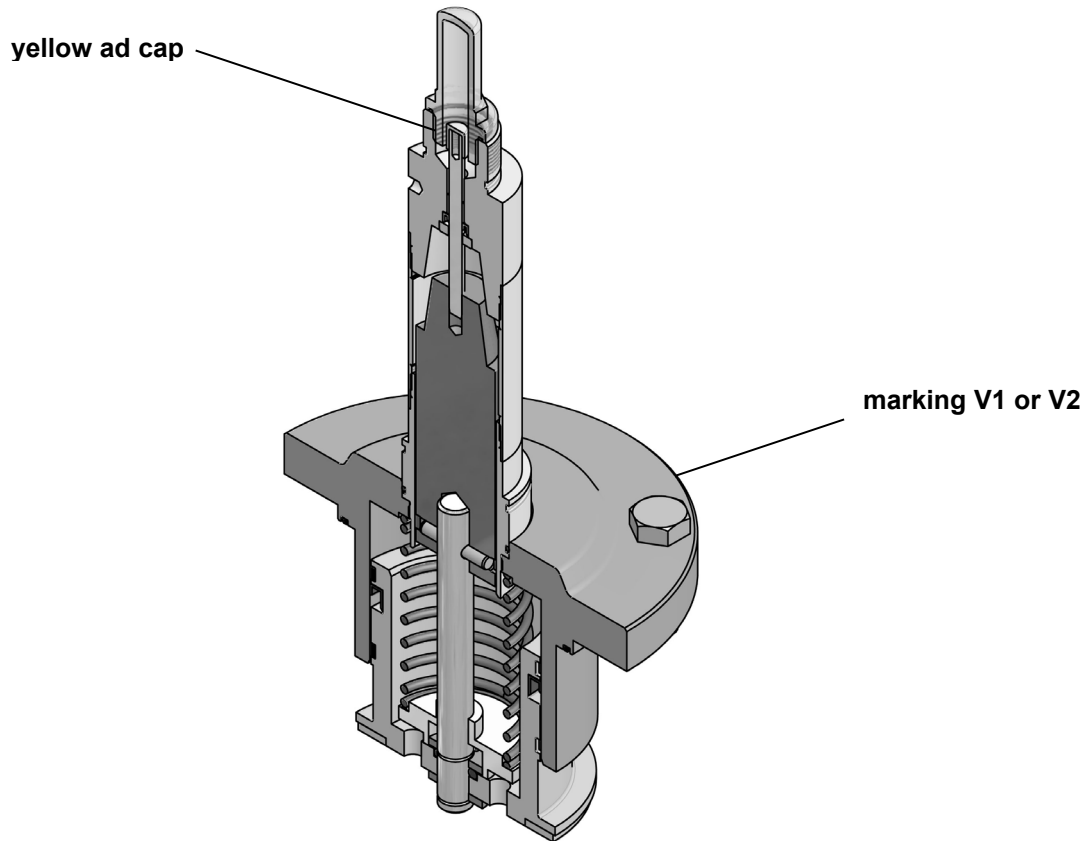

Fig.2 Valve unit 1 (V1) / valve unit 2 (V2)



NOTE!

In case of a visual check or in case of exchanging them the valve units 1 (V1) and/or 2 (V2) must not be interchanged, since otherwise the function of the double solenoid valve VX... can no longer be guaranteed.

Fig.3 option with adapter plate

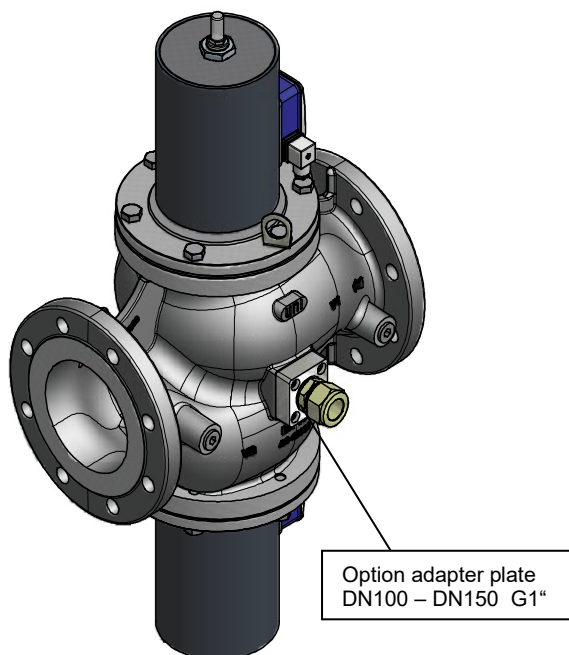
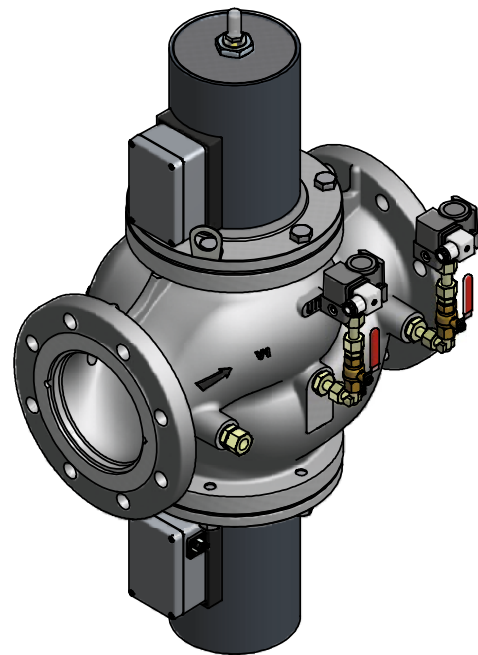

Fig.4 option pressure switch



11.2 List of parts

Pos./ Item	Stück/ Qty.	Benennung	Description
100	1	Ventilgehäuse	Valve chamber
102	1	Führungsrohr	Guide pipe
104	1	Oberteil	Upper part
109	1	Gehäusezylinder	Housing cylinder
108	1	Gehäuseflansch	Housing flange
205	1	Ventilspindel	Valve spindle
206/1	2	Führungsring	Guide ring
206/2	2	Führungsring	Guide ring
207	1	Magnetkern	Solenoid core
220	1	Ausgleichskolben	Balance piston
256	2	Transportwinkel	Transport angle
259	1	Scheibe (Fertigungsteil)	Disk (production piece)
281	1	Anzeigestift	Indicator pin
403/1	1	O-Ring	O-ring
403/2	1	O-Ring	O-ring
403/3	2	O-Ring	O-ring
403/4	1	O-Ring	O-ring
403/5	1	O-Ring	O-ring
404/1	1	Lippenring	Lip-ring
404/2	1	Lippenring	Lip-ring
503	1	Druckfeder	Pressure spring
505	1	Schutzkappe	Protective cap
531	1	Anzeigeplatte (gelb)	Yellow ad cap
800	1	Magnet-Antrieb	Solenoid drive
900	4	Sechskantschraube	Hex. head screw
901	1	Sechskantmutter	Hex. nut
904	3	Verschlussstopfen	Screwed plug
932	1	Sicherungsscheibe	Lock washer
1204	1	Zylinderstift	Cylinder pin

Wearing parts

Version	Fig.	Type	Spare parts
valve unit 1	Fig.2	VX65... VX80... VX100... VX150...	Spare part kit 1 (V1) complete Set spare part kit 3 (V1/V2) with mounting aid Solenoid drive (800)
valve unit 2	Fig.2	VX65... VX80... VX100... VX150...	Spare part kit 2 (V2) complete Set spare part kit 3 (V1/V2) with mounting aid Solenoid drive (800)

Dimension with standard solenoid drive

Flange DN	Dimension	65	80	100	150
Installation length	A ¹⁾	290	310	350	480
VX.....05	B	321	335	385	477
	B'	441	455	555	622
	ØC	110	110	135	160
	B	321	335	385	-
VX.....5	B'	441	455	555	-
	ØC	110	110	135	-
	B	321	335	385	-

A¹⁾ = Dimension at DIN (resp. flanges ASME and dimension DIN or flanges and dimension at DIN)

B' = Dimension for removing the solenoid drive

12.0 Declaration of Conformity

UNI-Geräte E. Mangelmann
Elektrotechnische Fabrik GmbH
Holtumsweg 13
D – 47652 Weeze



EU

Konformitätserklärung Declaration of Conformity

Produkt / Product	Automatisches Doppel Absperrventil - schließend bei Ausfall der Hilfsenergie / Automatic double shut off valve - closing in case of failure of auxiliary power		
Handelsbezeichnung / Trade Mark	Magnetventil / Solenoid valve		
Baureihe / Series	VX...		
Nennweiten / Size	DN 40^{b)} / 50^{b)} / 65^{a);b)} / 80^{a);b)} / 100^{a);b)} / 125^{b)} / 150^{a);b)}		
Druckstufe / Pressure Stage	PN 10^{a);b)} / 16^{a);b)}		
Fluidgruppe / Fluid Group	Brennbare Gase, FL. Gr.1 / Flammable gases, FL. Gr.1		
EU - Richtlinien / EU - Directives	EU/2016/426^{a)} Gasgeräteverordnung / Gas Appliance Regulation 2014/68/EU^{b)} Druckgeräterichtlinie / Pressure Equipment Directive		
Konformitätsbewertungsverfahren / Conformity Assessment Procedure	Modul B + D - EU/2016/426^{a)}; Modul H - 2014/68/EU^{b)}		
Angewandte technische Spezifikation / Applied Technical Specification	^{a)}DIN EN 161:2013-04; DIN EN 13611:2016-09; ^{b)}DIN EN 16668:2018-05; DIN EN 12266:2012-04		
Baumusterprüfung / Type Examination	CE-0085CR0022^{a)}	EU/2016/426	Modul B
	DVGW CERT GmbH Josef-Winter-Str. 1-3 D-53123 Bonn Zertifizierungsstelle / Notified Body 0085		
Überwachungsverfahren / Surveillance Procedure	SE-0085BL7038^{a)}	EU/2016/426	Modul D
	DVGW CERT GmbH Josef-Winter-Str. 1-3 D-53123 Bonn Zertifizierungsstelle / Notified Body 0085		
	CE-0062-PED-H-UGM 001-23-DEU^{b)}	2014/68/EU	Modul H
	Bureau Veritas Services SAS 8 Cours du Triangle 92800 PUTEAUX – LA DEFENSE Zertifizierungsstelle / Notified Body 0062		
Kennzeichnung / Marking	CE - 0085^{a)} 0062^{b)}	oder/lor	CE - 0062^{b)}

Das Unternehmen UNI Geräte E. Mangelmann Elektrotechnische Fabrik GmbH erklärt in alleiniger Verantwortung, dass die o.a. Baureihe die grundsätzlichen Anforderungen der aufgeführten Richtlinien und Normen erfüllt.

UNI Geräte E. Mangelmann Elektrotechnische Fabrik GmbH confirms under the sole responsibility of the manufacturer, that the basic requirements of the above specified directives and standards are fulfilled.

Weeze, 24.01.2023

Ort und Datum / place and date

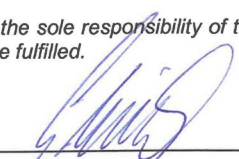
Geschäftsführer / Managing Director
Norbert Schneider

^{a); b)} Anwendung in Abhängigkeit von Nennweite und / oder Druckstufe: / Application depending on size and / or pressure stage:
DN ≤ 25 und / oder PS ≤ 0,5bar siehe Diagramm 6, oder Kat.1 + erfasst von EU/2016/426, fallen nicht in den Anwendungsbereich der 2014/68/EU
DN ≤ 25 and / or PS ≤ 0,5bar see diagram 6, or Kat.1 + under the scope of EU/2016/426, are not covered by the scope of the EU-Directive 2014/68/EU
250.100.009-04

UNI-Geräte E. Mangelmann
Elektrotechnische Fabrik GmbH
Holtumsweg 13
D – 47652 Weeze



UK Declaration of Conformity UK Konformitätserklärung

We / Wir: UNI-Geräte E. Mangelmann
Elektronische Fabrik GMBH
Holtumsweg 13
D – 47652 Weeze

Declare that / Erklären hiermit:

Product / Produkt	Automatic shut off valve – current less closed <i>Automatisches Absperrventil – stromlos geschlossen</i>
Trade Mark / Handelsbezeichnung	Solenoid valve / Magnetventil
Series / Baureihe	VX...
Size / Nennweiten	DN 65 / 80 / 100 / 150
Pressure Stage / Druckstufe	PN 10 / 16
Fluid Group / Fluidgruppe	Gas type of the 1st, 2nd and 3rd family gases <i>Gasart der 1., 2. und 3. Gasfamilie</i>

Satisfies the essential requirements of the Regulation 2016/426 on gas appliances as brought into UK law and amended and is manufactured in accordance with the UK designated standards:
Erfüllt die grundlegenden Anforderungen der Verordnung 2016/426 für Gasgeräte in der im Vereinigten Königreich geltenden und geänderten Fassung und wird in Übereinstimmung mit den im VK festgelegten Normen hergestellt:

Standards Numbers / Normen Nummern: BS EN 161:2011+A3:2013

BSI has performed the following conformity assessment procedures specified in the Regulation 2016/426 on gas appliances as brought into UK law and amended:
Das BSI hat die folgenden Konformitätsbewertungsverfahren durchgeführt, die in der Verordnung 2016/426 für Gasgeräte, wie sie in britisches Recht umgesetzt und geändert wurde, festgelegt sind:

Annex III Module B (Type Examination) and issued the Certificates below:

UKCA Module B certificate: (Certificate No.) UKCA 772903

*Anhang III Modul B (Baumusterprüfung) geprüft und die nachstehenden Bescheinigungen ausgestellt:
UKCA-Modul-B-Zertifikat: (Zertifikats-Nr.) UKCA 772903*

Annex III Module D (Conformity to Type based on Quality Assurance of the Production Process) and issued the Certificates below:

UKCA Module D certificate: (Certificate No.) UKCA 772905

*Anhang III Modul D (Konformität mit der Bauart auf der Grundlage der Qualitätssicherung des Produktionsprozesses) und stellte die nachstehenden Zertifikate aus:
UKCA-Modul-D-Zertifikat: (Zertifikats-Nr.) UKCA 772905*

Approved Body / Zugelassene Stelle: BSI Assurance UK Limited (Approved Body No. 0086)
Address / Adresse: Kitemark Court, Davy Avenue,
Knowlhill Milton Keynes MK5 8PP UK.

This declaration of conformity is issued under the sole responsibility of the manufacturer.
Diese Konformitätserklärung wird unter der alleinigen Verantwortung des Herstellers ausgestellt.

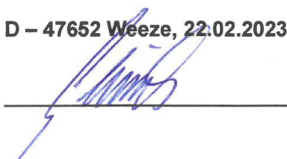
Name / Name: Norbert Schneider
Title / Position / Funktion: Dipl. Ing. / Managing Director / Geschäftsführer
Place & date of issue / Ort und Datum der Ausstellung: D – 47652 Weeze, 22.02.2023
Signature / Unterschrift: 

250.100.579-00