

# Operating and mounting manual automatic blow off valve solenoid-valve EVO / EVSO

## Contents

### 1.0 General Remarks

- 1.1 Valve data
- 1.2 Application

### 2.0 Danger Notices

- 2.1 Safety terms
- 2.2 Safety notice
- 2.3 Qualified staff
- 2.4 Unauthorized modification and spare part production
- 2.5 Unauthorized operation
- 2.6 Safety information for the use in explosion-prone areas guideline 2014/34/EU
- 2.7 Safety information regarding guideline 2014/68/EU attachment I

### 3.0 Handling

- 3.1 Transport
- 3.2 Storage
- 3.3 Handling before mounting

### 4.0 Product Description

- 4.1 Function
- 4.2 Technical data
- 4.3 Marking

### 5.0 Installation

- 5.1 Warning of dangers during installation, operation and maintenance
- 5.2 Installation

### 6.0 Operation

- 6.1 Commissioning
- 6.2 Shutting down
- 6.3 Maintenance
- 6.4 Putting back into operating

### 7.0 Troubleshooting

- 7.1 Detection of defects
- 7.2 Troubleshooting plan

### 8.0 Dismantling of the Valve

- 8.1 Replacement of wear parts

### 9.0 Warranty

### 10.0 Explanations on Codes and Directives

### 11.0 Sectional Drawing

- 11.1 Flange design / thread design
- 11.2 List of parts

## 1.0 General Remarks

This operating manual includes instructions to assemble and operate the valve in the prescribed and safe way. **Additionally, the adequate operating instructions of each special solenoid drive must be considered.**

Series MG...	220.100.038
Series MG...X	220.100.040
Series MG...Xme	220.100.039

If any difficulties appear that can not be solved by means of the operating manual, further information may be demanded from the manufacturer.

This operating manual is in accordance with the relevant valid EN safety standards and the valid prescriptions and rules of the Federal Republic of Germany.

If the solenoids are used abroad of the FRG, the operator and/or the person who is responsible for the plant concept must take care that the valid national rules are met.

The manufacturer reserves the right of any technical change and improvement.

The use of these operating instructions suppose the qualification of the user according to paragraph 2.3 "qualified staff".

The operating staff must be trained in accordance with the operating instructions. The operating manual must always be available at the location where used.

### 1.1 Valve data

#### Manufacturer:

UNI Geräte E. Mangelmann  
Elektrotechnische Fabrik GmbH  
Holtumsweg 13  
D-47652 Weeze  
Telefon: +49 (0) 2837/9134-0  
Fax: +49 (0) 2837/1444  
E-Mail: [info@uni-geraete.de](mailto:info@uni-geraete.de)  
Homepage: [www.uni-geraete.de](http://www.uni-geraete.de)

#### Designation

Direct-acting, normally opened NO, spring-loaded automatic blow-off valve with solenoid actuator.

<b>Working pressure:</b>	1 -EVO	0 - 1bar
	4 -EVO	0 - 4bar
	6 -EVO	0 - 6bar
	10 -EVO	0 - 10bar
	16 -EVSO	0 - 16bar
	25 -EVSO	0 - 25bar
	40 -EVSO	0 - 40bar

**Medium temperature:** -20°C to + 60°C

**Working pressure** 40-EVSO 5NH 0 - 40bar

**Medium temperature:** -30°C to + 140°C

**Ambient temperature:** -20°C to + 60°C

**Fitting position:** vertical drive or vertical or horizontal.

**Switching cycles:** see operating instructions solenoid drive

**Threaded connection dimension at DIN ISO 228-1**

Connection G	1/4 (2)	3/8 (3)	1/2 (5)	3/4 (7)	1 (10)	1 1/4 (12)	1 1/2 (15)	2 (20)	Test pressure (*) PT
1 - EVO	X	X	X	X	X	-	-	-	PT 6
4 - EVO	X	X	X	X	-	-	-	-	PT 10
6 - EVO	-	X	X	-	-	-	-	-	PT 10
10 - EVO	-	-	-	-	X	-	-	-	PT 16
16 - EVSO	-	-	X(#)	-	-	-	-	-	PT 25
25 - EVSO	-	-	X(#)	-	-	-	-	-	PT 40
40 - EVSO	-	-	X(#)	X(#)	-	-	-	-	PT 40

(\*) Test pressure to perform leakage test "No FUNCTION TEST"

(#) Option with welding flanges 1/2, DN15 = 5N; 3/4, DN20 = 7N

X Type examination EU/2016/426, CE-0085AS0561, O Acceptance test certificate 3.2 possible, - not available,

**Flange connection measures acc. to DIN EN 1092-2 / ANSI**

Flange DN ANSI	PN	15 (5N) 1/2"	20 (7N) 3/4"	25 (10N) 1"	32 (12N) 1 1/4"	40 (15N) 1 1/2"	50 (20N) 2"	65 (25N) 2 1/2"	80 (30N) 3"	100 4"	Test pressure (*) PT
1 - EVO	16	X	X	X	X	X	X	-	-	-	PT 6
40 - EVSO	40	X	-	-	-	-	-	-	-	-	PT 40

(\*) Test pressure to perform leakage test "No FUNCTION TEST"

X Type examination EU/2016/426, CE-0085AS0561, O Acceptance test certificate 3.2 possible, - not available,

**Voltage:** VDC 12 – 440 (–15% to +10%)

VAC 24 – 500 (–15% to +10%)

**Protection type:** IP54 or IP65

**Frequency** 40 – 60 Hz

**Power** 10 – 4000W

Details to the electrical data can be found on the type sign and the adequate operating instructions of the solenoid valves.

**1.2 Application**

The solenoid-valves EVO and EVSO are used for the throughput of a medium without control energy and for discharging a leakage gas volume.

The valves are suitable for gases of the 1<sup>st</sup>, 2<sup>nd</sup> and 3<sup>rd</sup> gas families to DIN EN 437 and for neutral gases and as a variant with material design for aggressive gases such as e.g. biogas, sewage plant gas or dump gas.

If used in other cases, the operator must carefully check if construction/design of valve, accessories and materials are suitable for the new application. The range of application is subject to the responsibility of the plant planner. The service life of the valve is 20 years.

## 2.0 Danger Notices

### 2.1 Safety terms

The signal terms DANGER, CAUTION und NOTICE are used in this operating manual in case of notices concerning special dangers, or for unusual information requiring a special marking.



**DANGER!** means that in case of non-observance there is danger to life and/or considerable damage.



**CAUTION!** means that in case of non-observance there is danger of injury and/or damage.



**NOTICE!** means that attention is drawn to technical correlations/connections.

Observance of other, not especially marked notices concerning transport, assembly, operation and maintenance and other data (in the operating manual, product documentation and at the unit itself) is also essential, in order to avoid disturbances that might affect direct or indirect damage to property or injury to persons.

### 2.2 Safety notice

Non observance of safety instructions can lead to loss of any claim for damages.

Non observance can lead to the following mentioned dangers:

- Failure of important functions of the valve/plant
- Endangering of persons by electrical or mechanical influences.
- Protection against accidental contact for moving parts may not be removed as long as the valve is in operation.
- Leakage of dangerous media (e.g. explosive, toxic, hot) must be removed in the way that there is no danger for persons or environment. Laws and regulations must be observed.

### 2.3 Qualified staff

These are persons who are familiar with erection, assembly, starting, operation and maintenance of the product and who have special qualifications acc. to their activities and functions, e.g.:

- Instruction and obligation to carry out and meet all regional and in-house orders and requirements.
- Education or instruction according to the safety engineering standards in use and maintenance of adequate safety and working protection equipment.
- Training in first aid.

### 2.4 Unauthorized modification and spare part production

Modification or changes of the valve are only allowed after agreement of the manufacturer. Original drawings and accessories authorized by the manufacturer are for safety purposes. The use of other parts or unauthorized changes at the valve by third persons may cancel and abolish the manufacturer's liability for resulting consequences.

### 2.5 Unauthorized operation

Operational reliability of the delivered valve is only guaranteed in case of determined use in accordance to paragraph 1 of the operating manual. **The application limits mentioned on the type sign may on no account be exceeded.**

## 2.6 Safety information for the use in explosion-prone areas guideline 2014/34/EU

- The temperature of the medium must not exceed the respective temperature class, and respectively, the respective maximum permitted medium temperature as per operation guideline.
- If the valve is heated (e.g. heating jacket), care must be taken, that the specified temperature class is kept in the time.
- The valve must be connected to the ground.  
In the case most simple this can be realized via pipe screws by means of tooth disc.  
Otherwise the connection to the ground must be implemented by other measures e.g. cable links.
- Control valves, electrical and electrical/mechanical drives as well as sensors must undergo a separate conformity check as per ATEX. In doing so the respective safety and explosion protection information in the operation instructions are to taken into special consideration.
- Any modifications whatsoever to the valve are not allowed. The ATEX approval is void with immediate effect if the valve is modified without prior authorisation (even including painting).
- UNI-Geräte GmbH must be consulted before any modifications are made.

Furthermore we point out the guideline 1999/92/EG, which include the minimum regulations for the improvement of the health-related situation and the safety of the employees, who might be jeopardized by an explosive atmosphere.

## 2.7 Safety information regarding guideline 2014/68/EU attachment I



### **Danger!**

UNI valves are not an accessory with a safety function as defined in the PED 2014/68/EU Article 2 (4) and Article 4 (1) (d) by category IV  
Use or classify!

## 3.0 Handling

### 3.1 Transport

For any transport works, the generally recognised technical rules and standards as well as rules for prevention of accidents must be observed.

In case of transport, storage and stopping, the flange protection caps must be mounted at both valve flanges.

The goods to be transported must be carefully treated. During transport, the valve must be protected against strokes, impacts or vibration. The coat of lacquer may not be damaged. Transport temperature is  $-20^{\circ}\text{C}$  up to  $+60^{\circ}\text{C}$ .

**Never transport the valve at screwed cable glands, appliance plugs or add-on units.** The valve can be transported at ring nuts, flange borings or by means of a belt under the solenoid drive.

Transport the valve in a case or on a pallet with smooth base and put it softly on plain floor. **Never put the valve on limit switch box.**

The goods must be checked on completeness and transport damage. See also section 9.0

### 3.2 Storage

If the valve is not installed immediately after delivery, it must be stored properly.

- Storage temperature -20°C up to + 60°C, dry and clean.
- The lacquering protects against corrosion in neutral dry atmosphere. Do not damage colour.
- In humid rooms, a drying agent or a heating resp. is necessary because of condensation of water.

Requirements according to DIN 7716 (products made of caoutchouc and rubber) must be met.

### 3.3 Handling before mounting

- In case of valve with protection caps, they must be removed before being mounted!
- Protect against atmospheric influences such as humidity.
- Appropriate treatment protects against damage.

## 4.0 Product Description

The solenoid-valves in the EVO and EVSO series are direct-acting, normally opened NO, spring-loaded automatic blow off valves with solenoid actuator.

Sectional drawing 11.1 Fig.1 – Fig.9 shows the valve construction.

### 4.1 Function

By switching on the solenoid drive, the solenoid core (207) is drawn against the upper part (106). The pressure spring (503) is pressed and the valve disc (200) releases the valve cross section. The valve is closed.

The valve opened by switching off, interruption or failure of power energy to solenoid drive. Due to press of the pressure spring (503) the valve disc (200) closes. The valve is open.

### 4.2 Technical data

**Closing times:** 0,3 – 0,7s depends upon nominal width  
**Opening times::** < 1s

#### Solenoid –drive types MG...

Connection G	1/4	3/8	1/2	3/4	1	1 1/4	1 1/2	2
1 - EVO	3803 0801	004	004	005-3	008-2	-	-	-
4 - EVO	005-3	005-3	005-3	008-2	-	-	-	-
6 - EVO	-	005-3	005-3	-	-	-	-	-
10 - EVO	-	-	-	-	012	-	-	-
16 - EVSO	-	-	008-2	-	-	-	-	-
25 - EVSO	-	-	008-2	-	-	-	-	-
40 - EVSO	-	-	010	010	-	-	-	-

#### Solenoid –drive types MG...

Flange DN	15	20	25	32	40	50	65	80	100
Flange ANSI	1/2"	3/4"	1"	1 1/4"	1 1/2"	2"	2 1/2"	3"	4"
1 - EVO	008-2	008-2	010	012	014	016	-	-	-
40 - EVSO	018	-	-	-	-	-	-	-	-

#### Max. valve loading by pipe power

The indicated moments may not work longer than 10s.

DN		8	10	15	20	25	32	40	50	65	80	100	125	≥150
<b>Torsion</b>	<b>Nm</b>	80	35	50	86	125	160	200	250 <sup>1)</sup>	325 <sup>1)</sup>	400 <sup>1)</sup>	-	-	-
<b>Bending</b>	<b>Nm</b>	35	70	105	225	340	475	610	1100	1600	2400	5000	6000	7600

<sup>1)</sup> Not valid in case of valves with flanges

**Starting torque, pipe screws greased**

DN	8	10	15	20	25	32	40	50	65	80	100	125	≥150
Torque Nm	20	30	30	30	30	50	50	50	50	50	80	160	160

**Starting torque, product screws and nuts greased**

Screw	M6	M8	M10	M12	M16	M20	M24
Torque Nm	5	11	22	39	70	110	150

**4.3 Marking**

The type sign on the solenoid drive has the following information:

- Fabricator
- Valve type, nominal width, pressure and temperature indication, fitting position
- Year of construction/ production no.
- Valve class and valve group acc.
- CE-sign and no. of relevant location
- Fluid group and test pressure PT
- Solenoid drive type
- Electr. performance
- Voltage
- Frequency
- Protection type

When using solenoid drives for ex-protection zone 1 refer to information in the valid operating instructions.

Refer also to section 10.0.

**5.0 Installation**

**5.1 Warning of dangers during installation, operation and maintenance**



**DANGER!**

Safe operation of the valve can only be guaranteed if it is installed, commissioned and maintained by qualified personnel (see point 2.3 “Qualified staff”) correctly and in observance of the warnings in this operating manual. Apart from that, the operation safety order and the qualified use of tools and protection equipment must be guaranteed. The operating instructions for the valve must be observed during all work on or with the valve. Failure to observe these instructions may result in injury or in damage to the valve or other installations.

When the valve is used as a final sealing element, a safety precaution e.g. blanking disc, blind flange, etc., in accordance with the code of practice of the German Technical and Scientific Association for Gas and Water (DVGW) is recommended during all repair work.

**5.2 Installation**

Apart from the general installation guidelines, the following points should be observed:



**NOTICE!**

- Remove the flange covers.
- The inside of the valve and the pipeline must be free from foreign particles.
- Observe the installation position in relation to the flow direction, see markings on the valve.
- Centre gaskets between the flanges.
- The connecting flanges must be aligned.
- Ensure that none of the components is strained during installation.
- The valve must not be used as a fixed point; it is supported by the pipework system.
- Protect valves from soiling, particularly during construction work.
- Thermal expansion of the pipework must be equalized using compensators.

For shut-off / blow-off valves: Install dirt trap upstream of the valve.  
Observe the direction of flow.

The mesh size of the dirt trap must have the following properties:

- be smaller than 1.5 mm
- a test mandrel of 1 mm diameter to pass and not allow.

If two valves are combined to form a group, one dirt trap installed upstream of the first valve is sufficient. The UNI-Geräte dirt traps of the SFR Series are approved for use together with the solenoid valves in accordance with EU/2016/426.



**NOTICE!**

Please observe the solenoid drive operating instructions.

## 6.0 Operation



**DANGER!**

Before commissioning a new installation or before starting up an installation again after repairs or modifications, ensure:

- The proper completion of all installation and assembly work!
- Commissioning only by “qualified staff” (see point 2.3).
- Installation or repair of existing guards and protection equipment.

### 6.1 Commissioning

- Before commissioning, check the data on material, pressure, temperature and flow direction with the layout plan of the pipework system.
- Depending on the field of application, the local regulations have to be observed, e.g. the operation safety order.
- Residues in the pipework and the valve (dirt, weld beads, etc.) will inevitably result in leaks.
- Leakage inspection of the installed valve.

### 6.2 Shutting down

- Depending on the field of application, the local regulations have to be observed, e.g. the operation safety order.

### 6.3 Maintenance

Solenoid valves have to be checked at regular intervals for proper function and internal leak tightness. The intervals for regular inspections have to be defined by the operator according to the operating conditions. UNI-Geräte recommends an internal visual inspection once a year and an overhaul of the valve after 2 years or after the following number of switching cycles at the latest:

Application temperature	DN ≤ 25	≤ DN 80	≤ DN 150	> DN 150
≤ 25°C	150 000	75 000	25 000	20 000
> 25°C	50 000	25 000	25 000	5 000

**UNI-Geräte prescribes the following maintenance intervals for valves with SIL requirements:**

The safety requirements with regard to the maintenance intervals to be adhered are described in the **SIL manual** of the type series and must be complied with.

### 6.4 Putting back into operation

When putting a valve back into operation, ensure that all the necessary steps described in section 5.2 (Installation) and section 6.1 (Commissioning) are repeated.



## 7.0 Troubleshooting

### 7.1 Detection of defects



**DANGER!**

Be sure to observe the safety instructions during troubleshooting.

If the malfunctions cannot be remedied using the following **“Troubleshooting plan (7.2)”** please contact the manufacturer.

In the event of faults in the function or operating behaviour of the valve, check whether the installation work was carried out and completed as described in this operating manual. Depending on the field of application, the operation safety order must be observed.

Check the data on material, pressure, temperature, voltage and flow direction with the layout plan of the pipework system. In addition, check whether the operating conditions correspond to the technical data in the data sheet or on the rating plate.

### 7.2 Troubleshooting Plan

Malfunction	Possible causes	Remedy
No flow	Valve does not open	Switch off solenoid drive (800) Check, if there is still any residual voltage.
	Flange covers were not removed	Remove flange covers
Low flow rate	Clogging in the pipework system	Check pipework system
	Contaminated strainer	Filter clean/exchange
Valve leaking at seat, no internal tightness	Valve seat gasket (400) or valve seat (100) damaged by external particles	See section 8 or replace valve
No external tightness	Gaskets damaged	See section 8 or replace valve
Valve does not close	Working pressure too high.	Compare working pressure with statement on type plate.
Flange fracture (valve/ pipework)	Screws not tightened uniformly, mating flanges not aligned	Align pipework. Install new valve



**NOTICE!**

Observe section 9.0 before all installation and repair work!

Observe section 6.4 when putting the valve back into operation!

## 8.0 Dismantling of the Valve

In addition to the general installation guidelines and the operation safety order, the following points must also be observed:



**DANGER!**

- Depressurised pipework system
- Cooled medium
- Emptied installation
- Vent pipework systems containing corrosive, inflammable, aggressive or toxic media
- Have dismantling work carried out only by qualified staff (see point 2.3)

### 8.1 Replacement of wear parts

Shut down the valve as described in section 6.2.

Switch off and dismantle the solenoid drive as described in the operating manual of the solenoid drive.



**DANGER!**

After continuous operation, the solenoid drive may be hot! Danger of burns!

During the visual inspection, pay attention to the following points:

1. Damage to the valve seat (100).
2. Damage to the valve disc seal (400)
3. Wear of the guide rings (206)

In case of damage to the valve seat, replace the whole valve.

If the sealing element becomes damaged (only applies to flange version Fig. 1), the spare parts kit should be used.

**Flange Version**

**Fig. 1 1-EVO 5NHR – 20NHR...**

Unscrew hex. head screws (900/2) and de-install housing flange (108/2) including lock washer (905/2). Remove upper part of housing (106) from solenoid core (207). Afterwards remove bolt (902/1) together with SL-retainer (949/2) and de-install solenoid core (207) with spring cap (203), spring guide pin (204) and pressure spring (503) putting them onto a clean pad.

Loosen hex. head screws (900/1) and unscrew housing flange (108/1) with lock washer (905/1) from the valve chamber (100). Completely remove valve disc (200; 201; 202; 205; 400; 403/1; 902/2; 943; 949/1) from valve chamber (100).



**NOTICE!**

Before assembly, replace flat gasket (402/1/2).



**CAUTION!**

Install wear parts carefully and properly and do not damage them during assembly.

Assemble the valve in the reverse order to the dismantling.

Examine the valve acc. to DIN EN 12266-1 for internal and external leaks and finally carry out a function test.

**Fig. 2 40-EVSO 5NHR..**

Replace the complete valve

**Thread version**

**Fig. 3 1-EVO 2R..**

**Fig. 4 1-EVO 3-10R.. ; 4-EVO 2-7R..**

**Fig. 5 6-EVO 3/5R..**

**Fig. 6 10-EVO 10R..**

**Fig. 7 16-EVSO 5R..**

**Fig. 8 25-EVSO 5R..**

**Fig. 9 40-EVSO 5R..**

Replace the complete valve

## 9.0 Warranty

Scope and period of the warranty is specified in the edition of the "General Terms of Business of the UNI-Geräte E. Mangelmann Elektrotechnische Fabrik GmbH" valid at the time of delivery or else in the purchase agreement.

We warranty that the valve is free from faults in line with the state of the art and for the confirmed field of application.

No warranty claims will be accepted for damage resulting from improper use or failure to observe these operating and installation instructions, the statutory accident prevention regulations, the EN, DIN and VDE standards and other codes and regulations.

Warranty claims will also not be accepted for damage occurring during operation due to operating conditions deviating from those specified in the data sheet or in other agreements.

Justified complaints will be remedied by reworking by us or specialist companies authorised by us.

Claims going beyond the scope of the warranty will not be accepted. The customer shall have no right to the supply of a replacement valve.

Maintenance work, installation of parts from other manufacturers, any modifications to the design and natural wear are not covered by the warranty.

Transport damage must be reported not to us but **without delay** to your responsible goods handling company, the railway company or the shipping agent as otherwise all claims for damages against these companies will be voided.

## 10.0 Explanations on Codes and Directives

The Commission of the European Union has laid down common directives resp. regulations for the free trading of goods within the Union specifying minimum requirements for safety and health protection. The CE symbol confirms that products comply with the EU directives resp. regulations, i.e. in conformity with the relevant, in particular harmonised standards. Regulation EU/2016/426 and directive 2014/68/EU are of relevance for the valve (mechanical part).

### Notes on Regulation EU/2016/426 (Gas Appliances Regulation GAR):

The valves have been developed, manufactured and tested in compliance with the applicable harmonised standard and comply with the relevant requirements of the Regulation EU/2016/426. Unless otherwise stated separately, this has been confirmed by a type examination.

### Notes on Directive 2014/68/EU (Pressure Equipment Directive, DGRL):

It has been confirmed that the quality assurance in design control, manufacture and final acceptance of the manufacturer, UNI-Geräte E. Mangelmann Elektrotechnische Fabrik GmbH, satisfy the requirements of 2014/68/EU Article 14 Module H. The valves comply with the fundamental requirements of Directive 2014/68/EU. Valves in according to Article 1 Paragraph 2,f,v or Article 4 paragraph 3 are not allowed to have the CE Mark in according to Article 18.

### Note concerning ex-guideline 2014/34/EU (explosion guideline ATEX):

The product is not subject to guideline 2014/34/EU, since due to the loads occurring during practical operation, there is no effective source of ignition even in case of an error case to be assumed. This also applies to spring loaded components in medium filled rooms. In case of electric drives, sensors or other electric components the application as per 2014/34/EU is to be checked separately.

## 11.0 Sectional drawing

11.1 Fig. 1 Flange design: 1-EVO 5NHR – 20NHR...

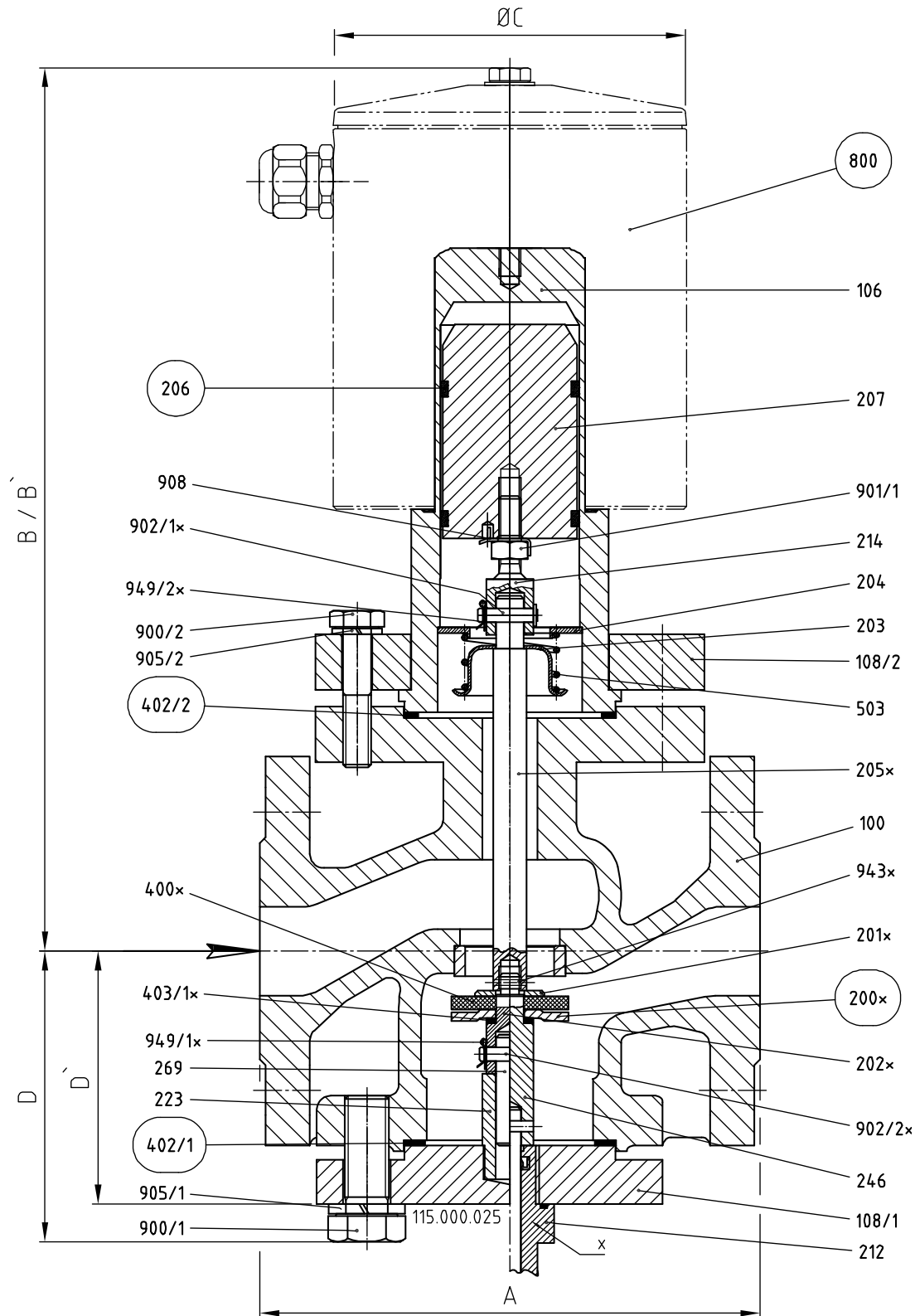



 = Spare part kit

**X** = Option limit switch mounting

(...x) supplied as a complete unit

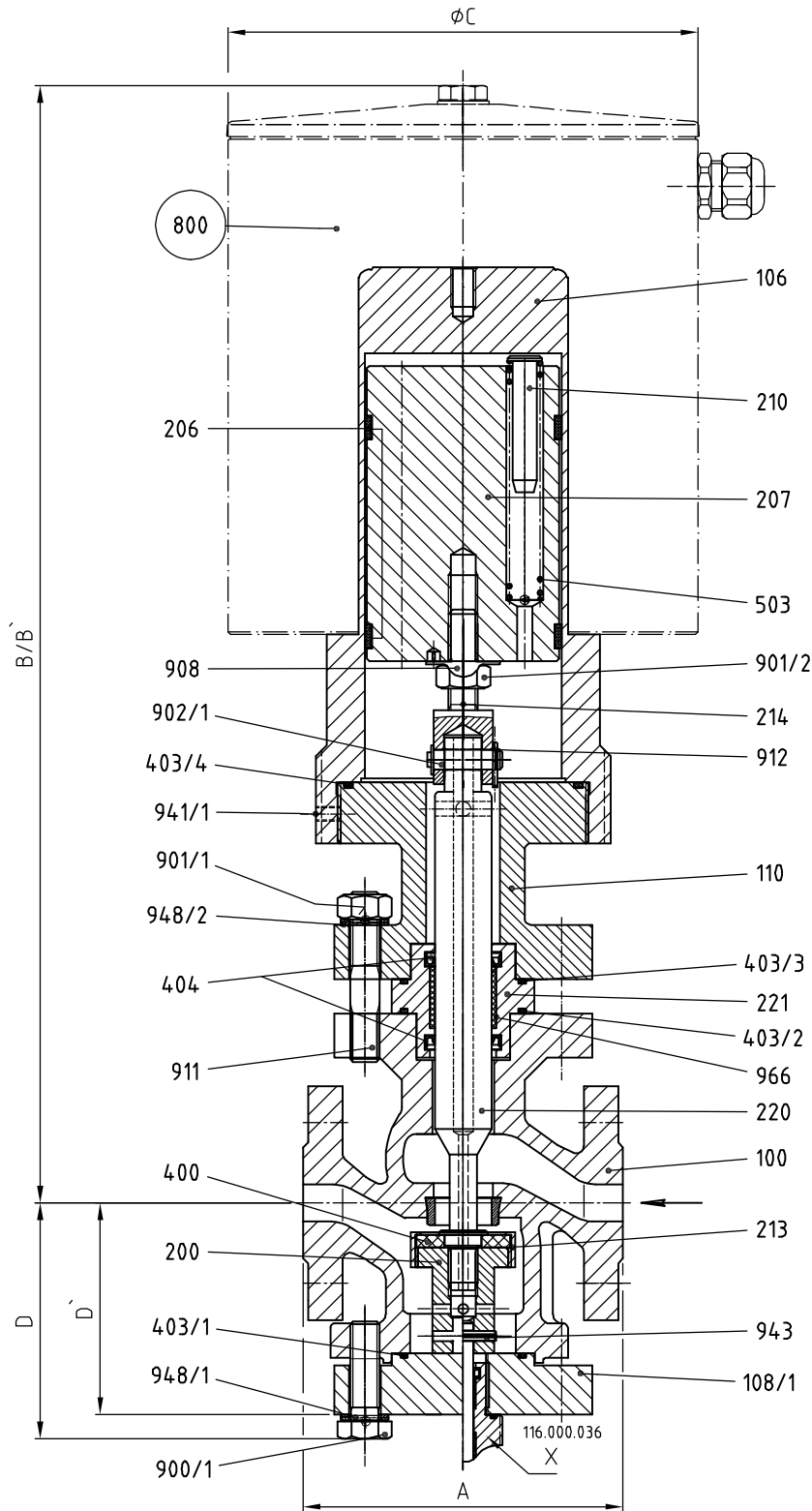
Fig. 2 Flange design: 40-EVSO 5NHR...



 = Spare part kit

X = Option limit switch mounting

Fig. 3 Thread design: 1-EVO 2R

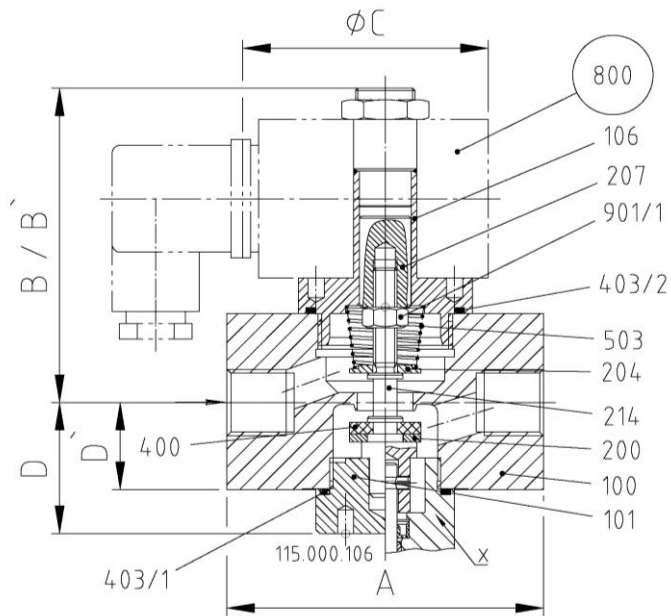

Fig. 4 Thread design: 1-EVO 3-10R ; 4-EVO 2-7R

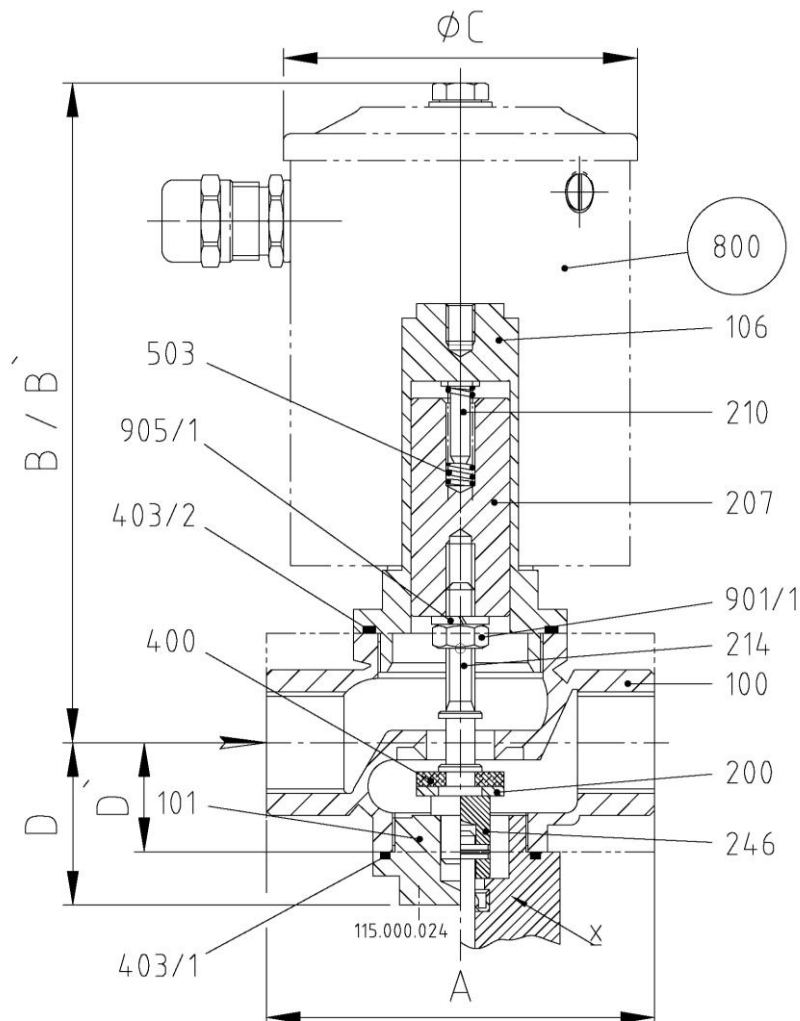

Fig. 5 Thread design: 6-EVO 3/5R

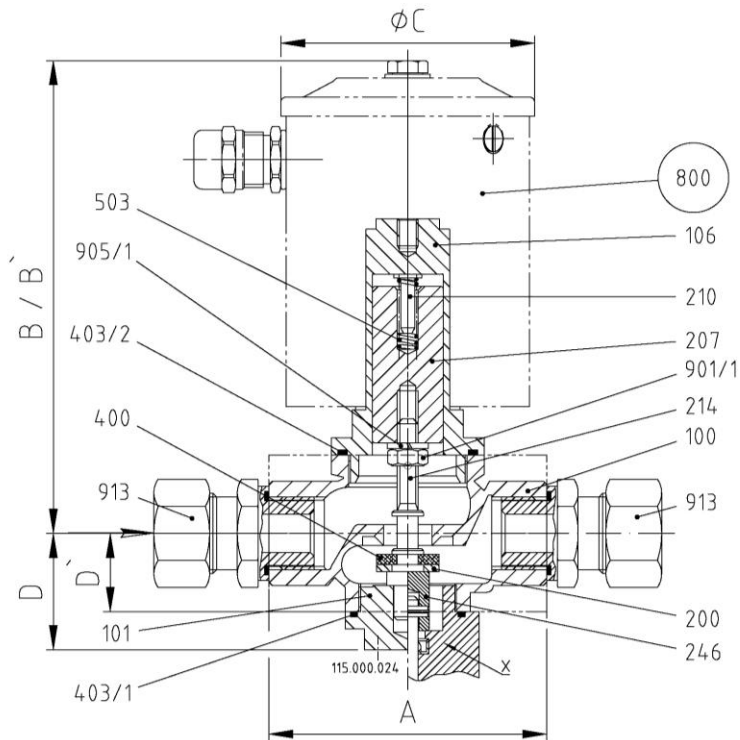

Fig. 6 Thread design: 10-EVO 10R

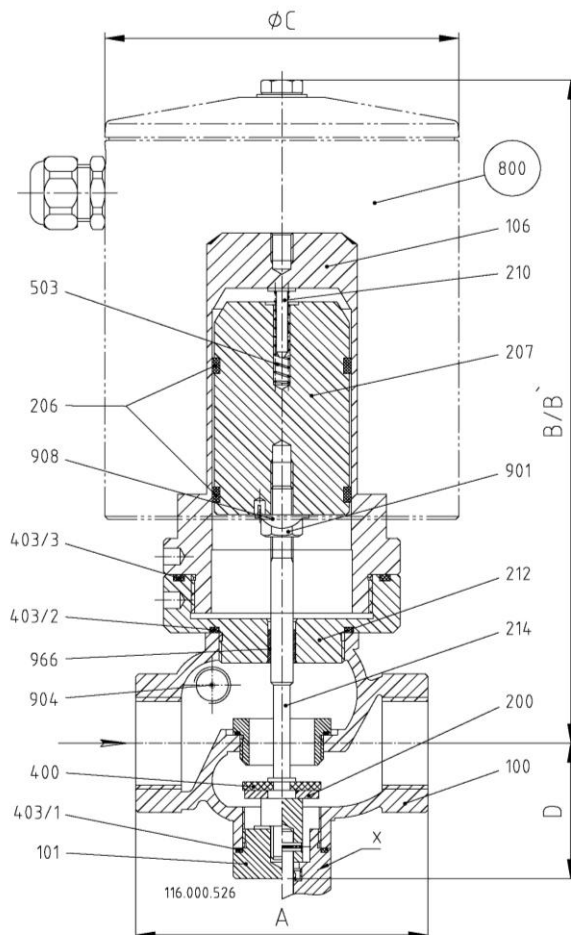

Fig. 7 Thread design: 16-EVSO 5R

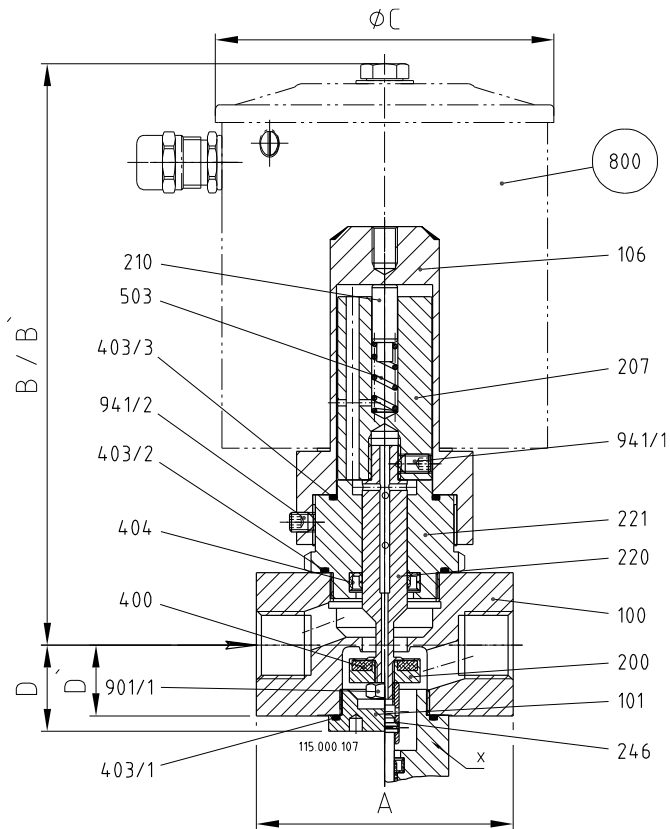

Fig. 8 Thread design: 25-EVSO 5R

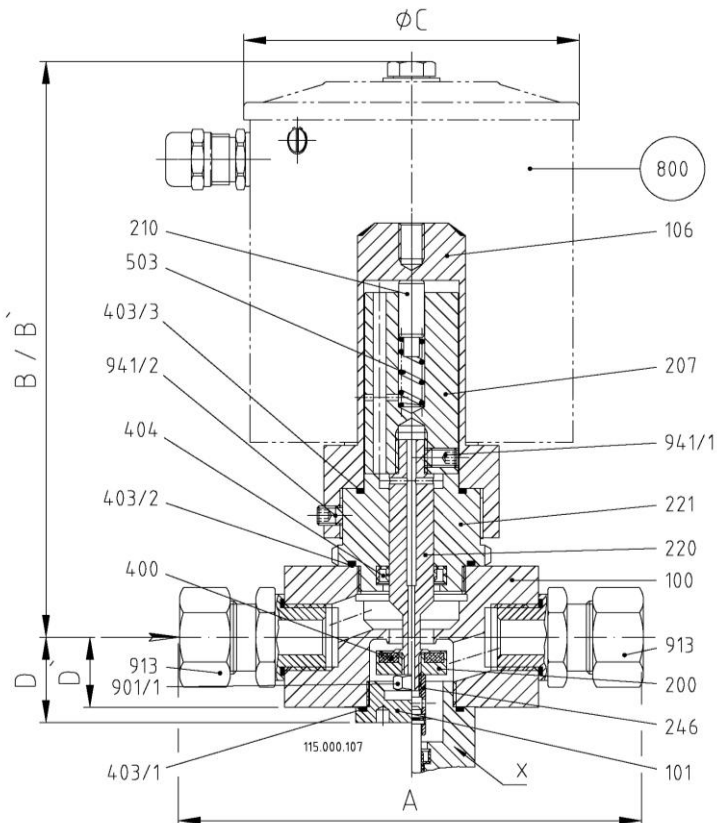
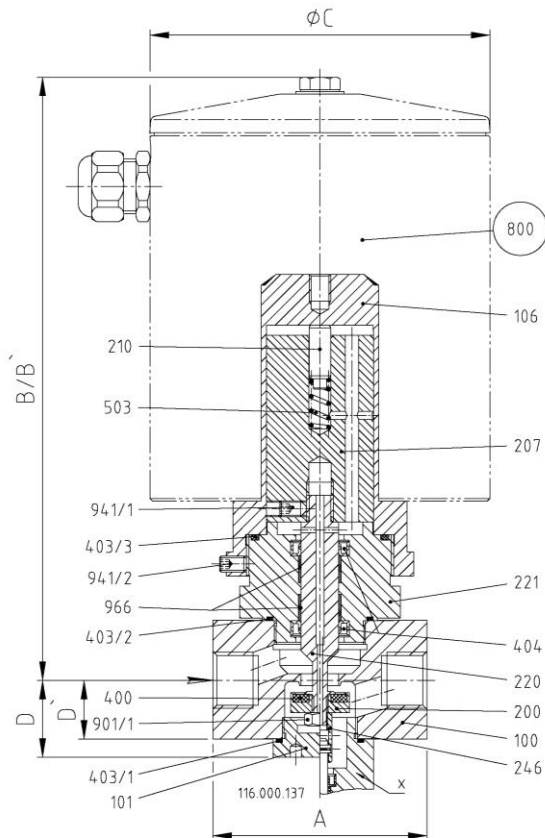



Fig. 9 Thread design: 40-EVSO 5/7R



## 11.2 List of parts

Pos./ Item	Stück/ Qty.	Benennung	Description
100	1	Ventilgehäuse	Valve chamber
101	1	Gehäusemutter	Housing nut
106	1	Gehäuseoberteil	Upper part of housing
108/1	1	Gehäuseflansch	Housing flange
108/2	1	Gehäuseflansch	Housing flange
110	1	Distanzstück	Spacer
200	1	Ventilteller	Valve disc
201	1	Tellerscheibe	Disc plate
202	1	Ventilstück	Valve piece
203	1	Federkappe	Spring cap
204	1	Federführung	Spring guide pin
205	1	Ventilspindel	Valve spindle
206	2	Führungsring	Guide ring
207	1	Magnetkern	Solenoid core
210	1	Federbolzen	Spring bolt
213	1	Gewinding	Threaded ring
214	1	Ventilstift	Valve pin
220	1	Ausgleichskolben	Balance piston
221	1	Kolbenführung	Piston guide
223	1	Buchse	Bush
246	1	Verbindungsstück Endschalter	Connction piece limit switch
269	1	Führungsbolzen	Guide bolt
400	1	Ventiltellerdichtung	Valve disc sealing
402/1	1	Flachdichtung	Flat gasket
402/2	1	Flachdichtung	Flat gasket
403/1	1	O-Ring	O-ring
403/2	1	O-Ring	O-ring

Pos./ Item	Stück/ Qty.	Benennung	Description
403/3	1	O-Ring	O-ring
403/4	1	O-Ring	O-ring
404	1	Lippenring	Lip-ring
503	1	Druckfeder	Pressure spring
800	1	Magnet-Antrieb	Solenoid drive
900/1	4	Sechskantschraube	Hex. head screw
900/2	4	Sechskantschraube	Hex. head screw
901/1	1	Sechskantmutter	Hex. nut
901/2	1	Sechskantmutter	Hex. nut
902/1	1	Bolzen	Bolt
902/2	1	Bolzen	Bolt
905/1	1/4	Federring	Lock washer
905/2	4	Federring	Lock washer
908	1	Sicherungsblech	Safety plate
911	4	Stiftschraube	Headless screw
912	1	Splint	Split-pin
913	2	Gerade Einschraubverschraub.	Linear threaded screw connection
941/1	1	Gewindestift	Setscrew
941/2	1	Gewindestift	Setscrew
943	1	Spannstift	Spring dowel sleeve
948/1	4	Nordlockscheiben	Safety disc
948/2	4	Nordlockscheiben	Safety disc
949/1	1	SL-Sicherung	SL-retainer
949/2	1	SL-Sicherung	SL-retainer
966	1/2	DU-Buchse	DU-liner

**Spare parts kit**

Version	Fig.	Type	Spare parts kit
<b>Flange version</b>	1	1- EVO 5N(H)R -20N(H)R..	Spare part kit, Solenoid drive (800)
	2	40- EVSO 5NH...	Solenoid drive (800)
<b>Thread version</b>	3	1- EVO 2R	Solenoid drive (800)
	4	1- EVO 3-10R	Solenoid drive (800)
		4- EVO 2-7R	
	5	6- EVO 3/5R	Solenoid drive (800)
	6	10- EVO 10R	Solenoid drive (800)
	7	16- EVSO 5R	Solenoid drive (800)
	8	25- EVSO 5R	Solenoid drive (800)
9	40- EVSO 5/7R	Solenoid drive (800)	

**Dimension with standard solenoid drive**

Connection G	Dimension	1/4	3/8	1/2	3/4	1	1 1/4	1 1/2	2
<b>Installation length</b>	<b>A</b>	60	80(140*)	80(140*)	95**	105	-	-	-
<b>1-EVO **</b>	<b>B</b>	80	136	136	143	190	-	-	-
	<b>B'</b>	140	196	196	203	265	-	-	-
	<b>ØC</b>	62	83	83	83	106	-	-	-
	<b>D</b>	31	34	34	42	56	-	-	-
	<b>D'</b>	20	23	23	30	39	-	-	-
<b>4-EVO **</b>	<b>B</b>	136	137	137	165	-	-	-	-
	<b>B'</b>	196	197	197	240	-	-	-	-
	<b>ØC</b>	83	83	83	106	-	-	-	-
	<b>D</b>	31	34	34	42	-	-	-	-
	<b>D'</b>	20	23	23	30	-	-	-	-
<b>6-EVO *</b>	<b>B</b>	-	137	137	-	-	-	-	-
	<b>B'</b>	-	197	197	-	-	-	-	-
	<b>ØC</b>	-	83	83	-	-	-	-	-
	<b>D</b>	-	34	34	-	-	-	-	-
	<b>D'</b>	-	23	23	-	-	-	-	-

Connection G	Dimension	1/4	3/8	1/2	3/4	1	1 1/4	1 1/2	2
<b>Installation length</b>	<b>A</b>	60	80(140*)	80(140*)	95**	105	-	-	-
<b>10-EVO</b>	<b>B</b>	-	-	-	-	240	-	-	-
	<b>B`</b>	-	-	-	-	335	-	-	-
	<b>ØC</b>	-	-	-	-	127	-	-	-
	<b>D</b>	-	-	-	-	49	-	-	-
	<b>D`</b>	-	-	-	-	-	-	-	-
<b>16/25-EVSO *</b>	<b>B</b>	-	-	180	-	-	-	-	-
	<b>B`</b>	-	-	255	-	-	-	-	-
	<b>ØC</b>	-	-	106	-	-	-	-	-
	<b>D</b>	-	-	28	-	-	-	-	-
	<b>D`</b>	-	-	23	-	-	-	-	-
<b>40-EVSO</b>	<b>B</b>	-	-	221	226	-	-	-	-
	<b>B`</b>	-	-	310	310	-	-	-	-
	<b>ØC</b>	-	-	127	127	-	-	-	-
	<b>D</b>	-	-	30	30	-	-	-	-
	<b>D`</b>	-	-	23	23	-	-	-	-

\* (140\*) = Anschlussausführung durch Gerade-Einschraubverschraubung  
Connection by linear threaded screw connection

\*\* Installation length A = 105 mm for valve chamber made of stainless steel

Flange DN	Dimension	15	20	25	32	40	50	65	80	100
<b>Installation length</b>	<b>A<sup>1)</sup></b>	130	150	160	180	200	230	290	310	350
Flange ANSI	Dimension	1/2"	3/4"	1"	1 1/4"	1 1/2"	2"	2 1/2"	3"	4"
<b>Installation length</b>	<b>A<sup>2)</sup></b>	108	118	127	140	165	203	216	241	292
<b>1-EVO</b>	<b>B</b>	212	212	303	321	388	400	-	-	-
	<b>B`</b>	287	287	393	420	508	535	-	-	-
	<b>ØC</b>	106	106	127	127	153	153	-	-	-
	<b>D</b>	84	84	84	103	103	111	-	-	-
	<b>D`</b>	74	74	74	89	89	97	-	-	-
<b>40-EVSO</b>	<b>B</b>	454	-	-	-	-	-	-	-	-
	<b>B`</b>	603	-	-	-	-	-	-	-	-
	<b>ØC</b>	194	-	-	-	-	-	-	-	-
	<b>D</b>	84	-	-	-	-	-	-	-	-
	<b>D`</b>	74	-	-	-	-	-	-	-	-

A<sup>1)</sup> = Dimension at DIN (resp. flanges ANSI and dimension DIN or flanges and dimension at DIN)

A<sup>2)</sup> = Dimension at ANSI 150lbs (see data sheet on our website armature installation length 225 100 026)

B` = Dimension for removing the solenoid drive