

Operating and mounting manual automatic blow off valve electro-pneumatic-valve 10/16/40-4 EPV(O)...N.R..

Contents

1.0 General remarks

- 1.1 Valve data
- 1.2 Application

2.0 Danger Notices

- 2.1 Safety terms
- 2.2 Safety notice
- 2.3 Qualified staff
- 2.4 Unauthorized modification and spare part production
- 2.5 Unauthorized operation
- 2.6 Safety information for the use in explosion-prone areas guideline 2014/34/EU
- 2.7 Safety information regarding guideline 2014/68/EU attachment I

3.0 Handling

- 3.1 Transport
- 3.2 Storage
- 3.3 Handling before mounting

4.0 Product Description

- 4.1 Function
- 4.2 Technical Data
- 4.3 Marking

5.0 Installation

- 5.1 Warning of dangers during installation, operation and maintenance
- 5.2 Installation

6.0 Operation

- 6.1 Commissioning
- 6.2 Shutting down
- 6.3 Maintenance
- 6.4 Putting back into operating

7.0 Troubleshooting

- 7.1 Detection of defects
- 7.2 Troubleshooting plan

8.0 Dismantling of the Valve

- 8.1 Replacement of wear parts

9.0 Warranty

10.0 Explanations on Codes and Directives

11.0 Drawing

- 11.1 Flange design
- 11.2 View drawing Flange design
- 11.3 Control valve
- 11.4 List of parts

1.0 General Remarks

This operating manual includes instructions to assemble and operate the valve in the prescribed and safe way. **Additionally and in accordance with the solenoid drive of the control valve (805), the relevant manufacturer`s operating instructions must be taken into consideration.**

If any difficulties appear that can not be solved by means of the operating manual, further information may be demanded from the manufacturer.

This operating manual is in accordance with the relevant valid EN safety standards and the valid prescriptions and rules of the Federal Republic of Germany. If the solenoids are used abroad of the FRG, the operator and/or the person who is responsible for the plant concept must take care that the valid national rules are met.

The manufacturer reserves the right of any technical change and improvement. The use of these operating instructions suppose the qualification of the user according to paragraph 2.3 "qualified staff". The operating staff must be trained in accordance with the operating instructions. The operating manual must always be available at the location where used.

1.1 Valve data

Manufacturer:

UNI Geräte E. Mangelmann
Elektrotechnische Fabrik GmbH
Holtumsweg 13
D-47652 Weeze
Telefon: +49 (0) 2837/9134-0
Fax: +49 (0) 2837/1444
E-Mail: info@uni-geraete.de
Homepage: www.uni-geraete.de

Designation

Direct-acting, normally opened NO, spring-loaded automatic blow-off valve with pneumatic actuator.

Working pressure	10 – 4-EPVO...N-4R	0 – 10 bar
	10 – 4-EPV....N.R...	0 – 10 bar
	16 – 4-EPV....N.R...	0 – 16 bar
	40 – 4-EPV....N.R...	0 – 40 bar

Medium temperature: -20°C to + 60°C

Ambient temperature: -20°C to + 60°C

Fitting position: vertical or horizontal drive.

Switching cycles: 500 cycles/h

Flange connection measures acc. to DIN EN 1092-2 / ANSI

Flange DN	PN	15 (5N)	20 (7N)	25 (10N)	40 (15N)	50 (20N)	65 (25N)	80 (30N)	100	150	Test pressure (*) PT
Flange ANSI	ANSI	1/2"	3/4"	1"	1 1/2"	2"	2 1/2"	3"	4"	6"	
10-4-EPVO..N-4R.	16	-	-	X	-	-	-	-	-	-	PT 16
10-4-EPV....N.R..	10-40	O	O	-	-	-	-	-	-	-	PT 16
16-4-EPV...N.R...	16	-	-	-	O	O	O	O	O	-	PT 24
40-4-EPV...N.R...	40	-	-	-	O	O	O	O	O	-	PT 40
40-4-EPV....N.R..	Class 300	-	-	-	-	-	O	O	-	-	PT 40

(*) Test pressure to perform leakage test "No FUNCTION TEST"

X Type examination EU/2016/426, CE-0085AS0513, O Acceptance test certificate 3.2 possible, - not available

Control medium: Air, nitrogen -20°C up to + 60°C

Control pressure: Min. control pressure, second number on type plate
Max. control pressure 10bar, e.g. 4-10bar

Electric connection control valve: Notice instructions on type plate of control valve

1.2 Application

The electro-pneumatic-valves EPV(O)..N.R... are used to control gas fittings for leakages and to blow off excess or leak gas.

The valves are suitable for gases of the 1st, 2nd and 3rd gas families to DIN EN 437 and for neutral gases and as a variant with material design for aggressive gases such as e.g. biogas, sewage plant gas or dump gas.

If used in other cases, the operator must carefully check if construction/design of valve, accessories and materials are suitable for the new application. The range of application is subject to the responsibility of the plant planner. The service life of the valve is 20 years.

2.0 Danger Notices

2.1 Safety terms

The signal terms DANGER, CAUTION und NOTICE are used in this operating manual in case of notices concerning special dangers, or for unusual information, requiring a special marking.



DANGER! means that in case of non-observance there is danger to life and/or considerable damage.



CAUTION! means that in case of non-observance there is danger of injury and/or damage.



NOTICE! means that attention is drawn to technical correlations/connections.

Observance of other, not especially marked notices concerning transport, assembly, operation and maintenance and other data (in the operating manual, product documentation and at the unit itself) is also essential, in order to avoid disturbances that might affect direct or indirect damage to property or injury to persons.

2.2 Safety notice

Non observance of safety instructions can lead to loss of any claim for damages.

Non observance can lead to the following mentioned dangers:

- Failure of important functions of the valve/plant
- Endangering of persons by electrical or mechanical influences.
- Protection against accidental contact for moving parts may not be removed as long as the valve is in operation.
- Leakage of dangerous media (e.g. explosive, toxic, hot) must be removed in the way that there is no danger for persons or environment. Laws and regulations must be observed.

2.3 Qualified staff

These are persons who are familiar with erection, assembly, starting, operation and maintenance of the product and who have special qualifications acc. to their activities and functions, e.g.:

- Instruction and obligation to carry out and meet all regional and in-house orders and requirements.
- Education or instruction according to the safety engineering standards in use and maintenance of adequate safety and working protection equipment.
- Training in first aid.

2.4 Unauthorized modification and spare part production

Modification or changes of the valve are only allowed after agreement of the manufacturer. Original drawings and accessories authorized by the manufacturer are for safety purposes. The use of other parts or unauthorized changes at the valve by third persons may cancel and abolish the manufacturer's liability for resulting consequences.

2.5 Unauthorized operation

Operational reliability of the delivered valve is only guaranteed in case of determined use in accordance to paragraph 1 of the operating manual. **The application limits mentioned on the type sign may on no account be exceeded.**

2.6 Safety information for the use in explosion-prone areas guideline 2014/34/EU

- The temperature of the medium must not exceed the respective temperature class, and respectively, the respective maximum permitted medium temperature as per operation guideline.
- If the valve is heated (e.g. heating jacket), care must be taken, that the specified temperature class is kept in the time.
- The valve must be connected to the ground.
In the case most simple this can be realized via pipe screws by means of tooth disc.
Otherwise the connection to the ground must be implemented by other measures e.g. cable links.
- Control valves, electrical and electrical/mechanical drives as well as sensors must undergo a separate conformity check as per ATEX. In doing so the respective safety and explosion protection information in the operation instructions are to taken into special consideration.
- Any modifications whatsoever to the valve are not allowed. The ATEX approval is void with immediate effect if the valve is modified without prior authorisation (even including painting).
- UNI-Geräte GmbH must be consulted before any modifications are made.

Furthermore we point out the guideline 1999/92/EG, which include the minimum regulations for the improvement of the health-related situation and the safety of the employees, who might be jeopardized by an explosive atmosphere.

2.7 Safety information regarding guideline 2014/68/EU attachment I



Danger!

UNI valves are not an accessory with a safety function as defined in the PED 2014/68/EU Article 2 (4) and Article 4 (1) (d) by category IV
Use or classify!

3.0 Handling

3.1 Transport

For any transport works, the generally recognised technical rules and standards as well as rules for prevention of accidents must be observed.

In case of transport, storage and stopping, the flange protection caps must be mounted at both valve flanges.

The goods to be transported must be carefully treated. During transport, the valve must be protected against strokes, impacts or vibration. The coat of lacquer may not be damaged. Transport temperature is -20°C up to $+60^{\circ}\text{C}$.

Never transport the valve at pneumatic drive pipings / tubings or components.

Transport the valve with a belt underneath the pneumatic actuator or on the transport angles / ring nuts provided.

Transport the valve in a box or on a pallet with soft base and put it smoothly on even floor. **Never put valve on the piping/tubing or its components.**

The goods must be checked on completeness and transport damage. See also section 9.0

3.2 Storage

If the valve is not installed immediately after delivery, it must be stored properly.

- Storage temperature -20°C up to + 60°C, dry and clean.
- The lacquer protects against corrosion in neutral dry atmosphere. Do not damage colour.
- In humid rooms, a drying agent or a heating resp. is necessary because of condensation of water.

Requirements according to DIN 7716 (products made of caoutchouc and rubber) must be met.

3.3 Handling before mounting

- In case of valve with protection caps, they must be removed before being mounted!
- Protect against atmospheric influences such as humidity.
- Appropriate treatment protects against damage.

4.0 Product Description

The electro-pneumatic-valves in the EPV(O)..N.R... series are direct-acting, normally opened NO, spring-loaded automatic blow off valves with pneumatic actuator.

The drive is actuated by a 3/2 way control valve with solenoid drive, type 10-EVD 2 or 10-EVD 2/2401 resp.

The sectional drawing part 11.1 in Fig. 1 to Fig. 2 shows the valve construction.

4.1 Funktion

On opening the 3/2 way control valve (805) the control medium flows above the drive piston (217) via connection 3 → 2. The control medium presses the drive piston (217) against the pressure spring (503) and closes the pressurized valve disc (200) (balance piston (220)) via the valve spindle (205). The valve is closed.

The valve opens due to shutting off, power failure or interruption of the energy supply to the control valve (805). The compressed control medium in the pneumatic drive is released via the quick venting mechanism (601), the sound absorber (600) and the control valve (805). The drive KA70 is only relieved via the control valve (805).

4.2 Technical data

Opening times: 0,7 – 1s depends upon nominal width
Closing times: 0,3 - 1s

Drive types and air consumption in standard litre (NL) per connection at 4 bar control pressure.

Flange DN Flange ANSI	15 1/2"	20 3/4"	25 1"	40 1 1/2"	50 2"	65 2 1/2"	80 3"	100 4"	150 6"
10-4-EPVO..N-4R.	-	-	KA 70 1 NL	-	-	-	-	-	-
10-4-EPV...N.R..	KA 70 1 NL	KA 70 1 NL	-	-	-	-	-	-	-
16-4-EPV...N.R...	-	-	-	KA 120 2,5 NL	KA160 4,5 NL	KA160 4,5 NL	KA160 4,5 NL	KA 200 9 NL	-
40-4-EPV...N.R...	-	-	-	KA 120 2,5 NL	KA160 4,5 NL	KA160 4,5 NL	KA160 4,5 NL	KA 200 9 NL	-

Air consumption for 10 bar, multiply control pressure table values by 2.2

Max. valve loading by pipe power

The indicated moments may not work longer than 10s.

DN		8	10	15	20	25	32	40	50	65	80	100	125	≥150
Torsion	Nm	20	35	50	85	125	160	200	250 ¹⁾	325 ¹⁾	400 ¹⁾	-	-	-
Bending	Nm	35	70	105	225	340	475	610	1100	1600	2400	5000	6000	7600

¹⁾ Not valid in case of valves with flanges

Starting torque, pipe screws greased

DN		8	10	15	20	25	32	40	50	65	80	100	125	≥150
Torque	Nm	20	30	30	30	30	50	50	50	50	50	80	160	160

Starting torque, product screws and nuts greased

Screw		M6	M8	M10	M12	M16	M20	M24
Torque	Nm	5	11	22	39	70	110	150

4.3 Marking

The type sign on the pneumatic drive has the following information:

- Fabricator
- Valve type, nominal width, pressure and temperature indication, fitting position
- Year of construction/ production no.
- Valve class and valve group acc.
- CE-sign and no. of relevant location
- Fluid group and test pressure PT
- Pneumatic drive type
- Control medium p_{min} and p_{max} for control medium

Refer also to section 10.0.

5.0 Installation

5.1 Warning of dangers during installation, operation and maintenance



DANGER!

Safe operation of the valve can only be guaranteed if it is installed, commissioned and maintained by qualified personnel (see point 2.3 "Qualified staff") correctly and in observance of the warnings in this operating manual. Apart from that, the operation safety order and the qualified use of tools and protection equipment must be guaranteed. The operating instructions for the valve must be observed during all work on or with the valve. Failure to observe these instructions may result in injury or in damage to the valve or other installations.

When the valve is used as a final sealing element, a safety precaution e.g. blanking disc, blind flange, etc., in accordance with the code of practice of the German Technical and Scientific Association for Gas and Water (DVGW) is recommended during all repair work.

5.2 Installation

Apart from the general installation guidelines, the following points should be observed:



NOTICE!

- Remove the flange covers.
- The inside of the valve and the pipeline must be free from foreign particles.
- Observe the installation position in relation to the flow direction, see markings on the valve.
- Centre gaskets between the flanges.
- The connecting flanges must be aligned.
- Ensure that none of the components is strained during installation.
- The valve must not be used as a fixed point; it is supported by the pipework system.
- Protect valves from soiling, particularly during construction work.
- Thermal expansion of the pipework must be equalized using compensators.

For shut-off / blow-off valves: Install dirt trap upstream of the valve.

Observe the direction of flow.

The mesh size of the dirt trap must have the following properties:

- be smaller than 1.5 mm
- a test mandrel of 1 mm diameter to pass and not allow.

If two valves are combined to form a group, one dirt trap installed upstream of the first valve is sufficient. The UNI-Geräte dirt traps of the SFR Series are approved for use together with the electro-pneumatic-valves in accordance with EU/2016/426.

The valve can be installed with vertical or horizontal pneumatic drive. The solenoid drive of the control valve should preferably be installed with vertical drive. The control air must be connected at connection 3. We recommend an air filter in front of the control valve. Mesh size 40 μ m.



NOTICE!

Please observe the control valve operating instructions.

6.0 Operation



DANGER!

Before commissioning a new installation or before starting up an installation again after repairs or modifications, ensure:

- The proper completion of all installation and assembly work!
- Commissioning only by "qualified staff" (see point 2.3).
- Installation or repair of existing guards and protection equipment.

6.1 Commissioning

- Before commissioning, check the data on material, pressure, temperature and flow direction with the layout plan of the pipework system.
- Depending on the field of application, the local regulations have to be observed, e.g. the operation safety order.
- Residues in the pipework and the valve (dirt, weld beads, etc.) will inevitably result in leaks.
- Leakage inspection of the installed valve.

6.2 Shutting down

- Depending on the field of application, the local regulations have to be observed, e.g. the operation safety order.

6.3 Maintenance

Electro-pneumatic-valves have to be checked at regular intervals for proper function and internal leak tightness. The intervals for regular inspections have to be defined by the operator according to the operating conditions. UNI-Geräte recommends an internal visual inspection once a year and an overhaul of the valve after 2 years or after the following number of switching cycles at the latest:

Application temperature	DN ≤ 25	≤ DN 80	≤ DN 150	> DN 150
≤ 25°C	150 000	75 000	25 000	20 000
> 25°C	50 000	25 000	25 000	5 000

UNI-Geräte prescribes the following maintenance intervals for valves with SIL requirements:

The safety requirements with regard to the maintenance intervals to be adhered are described in the **SIL manual** of the type series and must be complied with.

6.4 Putting back into operation

When putting a valve back into operation, ensure that all the necessary steps described in section 5.2 (Installation) and section 6.1 (Commissioning) are repeated.

7.0 Troubleshooting

7.1 Detection of defects



DANGER!

Be sure to observe the safety instructions during troubleshooting.

If the malfunctions cannot be remedied using the following **“Troubleshooting plan (7.2)”** please contact the manufacturer.

In the event of faults in the function or operating behaviour of the valve, check whether the installation work was carried out and completed as described in this operating manual.

Depending on the field of application, the operation safety order must be observed.

Check the data on material, pressure, temperature, voltage and flow direction with the layout plan of the pipework system. In addition, check whether the operating conditions correspond to the technical data in the data sheet or on the rating plate.

7.2 Troubleshooting plan

Malfunction	Possible causes	Remedy
No flow	Pneumatic drive does not open	Switch off control valve (805) Clean sound absorber (600)
	Flange covers were not removed	Remove flange covers
Low flow rate	Obstruction in the pipe system	Check pipe system
Valve leaking at seat, no internal tightness	Valve disc sealing (400) damaged by external particles	See section 8 or replace valve
No external tightness	Gaskets damaged	See section 8 or replace valve
Valve closes too slowly	Exhaust plug (983) in spacer (110) closed	Clean exhaust plug (983)
	Control pressure too low	Check control pressure
	Reduced conductor cross sections	Replace folded control lines
Valve opens too slowly	Dirt in control line	Clean sound absorber (600)
		Clean vent line
Valve does not close	Control valve does not open	Check, if residual voltage is aligned
	Dirt in control line	If necessary, clean filter in control line
	Reduced conductor cross sections	Replace folded control lines
Flange fracture (valve/pipework)	Screws not tightened uniformly, mating flanges not aligned	Align pipework. Install new valve



NOTICE!

Observe section 9.0 before all installation and repair work

Observe section 6.4 when putting the valve back into operation!

8.0 Dismantling of the Valve

In addition to the general installation guidelines and the operation safety order, the following points must also be observed:



DANGER!

- Depressurised pipework system
- Cooled medium
- Emptied installation
- Vent pipework systems containing corrosive, inflammable, aggressive or toxic media
- Have dismantling work carried out only by qualified staff (see point 2.3)



NOTICE!

Fittings with an approval for ships (inspection certificate 3.2 as per EN10204 (01/2005), for the series: 10-4 EPVO 10N-4R..., must be completely exchanged.

8.1 Replacement of wear parts

Shut down the valve as described in section 6.2.

Switch off control valve (800) and disassemble the control line from pneumatic drive.

Remove attachments (limit switch mounting).

Fig.1 Flange version 16/40-4-EPV ...(N).R...

Remove protective cap (505). Loosen hex. nut (901/3) with lock washer (905/3) and remove stud (236/2).



DANGER!

Disassembly spring disk (216).

Spring disk (216) with drive piston (217) is under spring tension. By depressing the spring disk (216) and loosen the nconnection piece limit switch (246) with lock washer (905/4), the pressure spring (503) are relaxed.

Remove pressure spring (503), sealing piece (226), drive piston (217), spring disk (216) and pneumatic cylinder (111).

Loosen the cylinder head screw (910) with lock washer (905/2). Remove spacer (110) with spindle guide (212/2) from valve spindle (205).

Loosen and remove hex. nut (901/2) with lock washer (905/1). Remove the housing flange (108).

Pull the piston guide (221) with balance piston (220), valve spindle (205) out of valve chamber (100).

Screw spindle nut (219) out of balance piston (220) and remove valve spindle (205).



NOTICE!

Two-piece ring (218) falls out.



NOTICE!

Spare part kit 1 includes a complete balance piston (220*).
The position numbers marked with a (*) are supplied as complete unit.

Fig.2 Flange version 10-4-EPVO 10N-4R

Flange version 10-4-EPV 5/7N.R..

Remove protective cap (505). Loosen hex. nut (901/2) with lock washer (905/3) and remove stud (236).



DANGER!

Disassembly spring disk (216).

Spring disk (216) with drive piston (217) is under spring tension. By depressing the spring disk (216) and loosen the nut (901/1) with lock washer (905/4), the pressure spring (503) are relaxed.

Remove pressure spring (503), sealing piece (226), drive piston (217), spring disk (216), spring guide (204) and pneumatic cylinder (111).

Loosen the cylinder head screw (910). Remove spacer (110) with spindle guide (212) from valve spindle (205).

Pull valve disk (200) with valve spindle (205) out of valve chamber (100).



NOTICE!

Spare part kit 2 includes a complete valve disk (200*).
The position numbers marked with a (*) are supplied as complete unit.

Assemble the valve in the reverse order to the dismantling.

Grease the valve spindle (205) in the sector of the lip-rings (404) and in the area of the two-piece ring (218) with lubricant Staburags N32 or equivalent material (DVGW-authorization).

Grease the pneumatic cylinder (111) in the sector of the drive piston (217) with lubricant Staburags NBU 30.



CAUTION!

Install sealing elements carefully and properly and do not damage them during assembly.

Examine the valve acc. to DIN EN 12266-1 for internal and external leaks and finally carry out a function test.

9.0 Warranty

Scope and period of the warranty is specified in the edition of the "General Terms of Business of the UNI-Geräte E. Mangelmann Elektrotechnische Fabrik GmbH" valid at the time of delivery or else in the purchase agreement.

We warranty that the valve is free from faults in line with the state of the art and for the confirmed field of application.

No warranty claims will be accepted for damage resulting from improper use or failure to observe these operating and installation instructions, the statutory accident prevention regulations, the EN, DIN and VDE standards and other codes and regulations.

Warranty claims will also not be accepted for damage occurring during operation due to operating conditions deviating from those specified in the data sheet or in other agreements.

Justified complaints will be remedied by reworking by us or specialist companies authorized by us.

Claims going beyond the scope of the warranty will not be accepted. The customer shall have no right to the supply of a replacement valve.

Maintenance work, installation of parts from other manufacturers, any modifications to the design and natural wear are not covered by the warranty.

Transport damage must be reported not to us but **without delay** to your responsible goods handling company, the railway company or the shipping agent as otherwise all claims for damages against these companies will be voided.

10.0 Explanations on Codes and Directives

The Commission of the European Union has laid down common directives resp. regulations for the free trading of goods within the Union specifying minimum requirements for safety and health protection. The CE symbol confirms that products comply with the EU directives resp. regulations, i.e. in conformity with the relevant, in particular harmonised standards. Regulation EU/2016/426 and directive 2014/68/EU are of relevance for the valve (mechanical part).

Notes on Regulation EU/2016/426 (Gas Appliances Regulation GAR):

The valves have been developed, manufactured and tested in compliance with the applicable harmonised standard and comply with the relevant requirements of the Regulation EU/2016/426. Unless otherwise stated separately, this has been confirmed by a type examination.

Notes on Directive 2014/68/EU (Pressure Equipment Directive, DGRL):

It has been confirmed that the quality assurance in design control, manufacture and final acceptance of the manufacturer, UNI-Geräte E. Mangelmann Elektrotechnische Fabrik GmbH, satisfy the requirements of 2014/68/EU Article 14 Module H. The valves comply with the fundamental requirements of Directive 2014/68/EU. Valves in according to Article 1 Paragraph 2,f,v or Article 4 paragraph 3 are not allowed to have the CE Mark in according to Article 18.

Note concerning ex-guideline 2014/34/EU (explosion guideline ATEX):

The product is not subject to guideline 2014/34/EU, since due to the loads occurring during practical operation, there is no effective source of ignition even in case of an error case to be assumed. This also applies to spring loaded components in medium filled rooms. In case of electric drives, sensors or other electric components the application as per 2014/34/EU is to be checked separately.

11.0 Sectional Drawing

11.1 Fig. 1 16/40-EPV....(N).R...

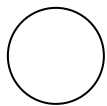
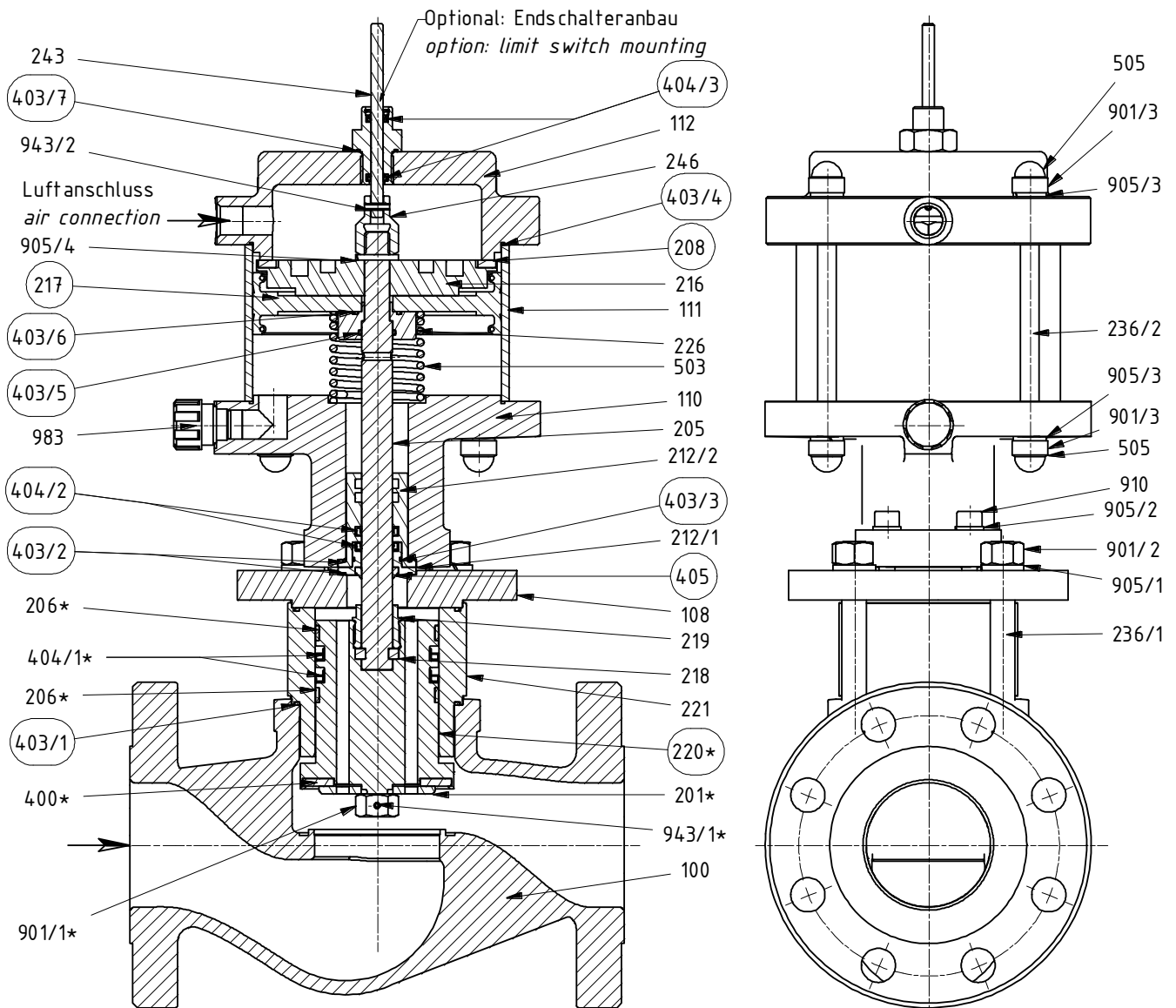

= Spare part kit

(...*) is supplied as a complete unit

Fig. 2 10-4-EPVO 10-4R... ; 10-4-EPV 5/7N.R...

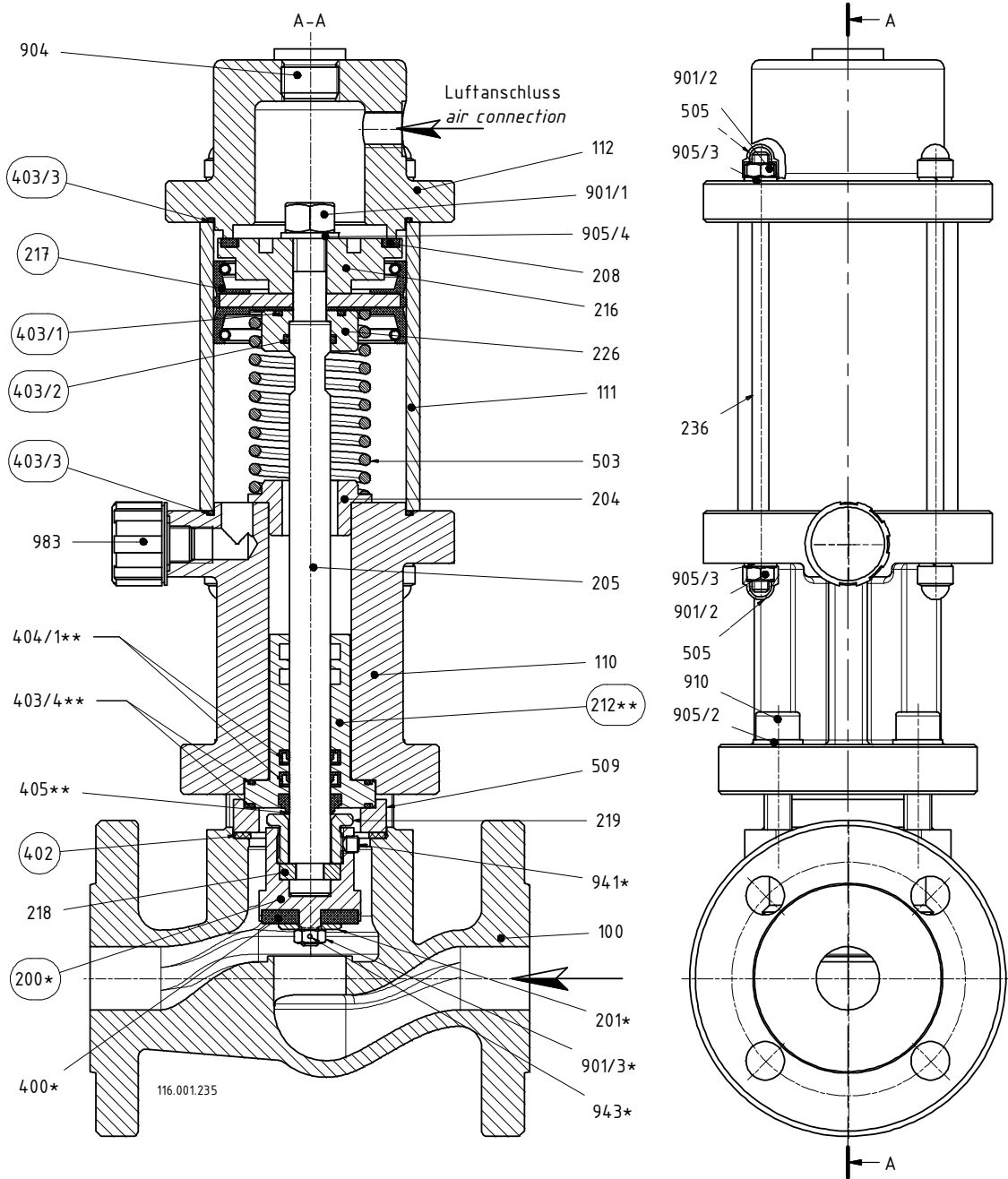

= Spare part kit

(...*), (...#) and (...+) are supplied as a complete unit

Detail limit switch mounting

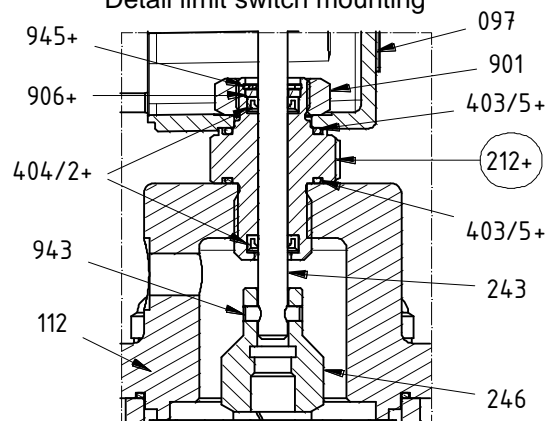

11.2 Projection
Fig.1 16/40-4-EPV...(N).R...

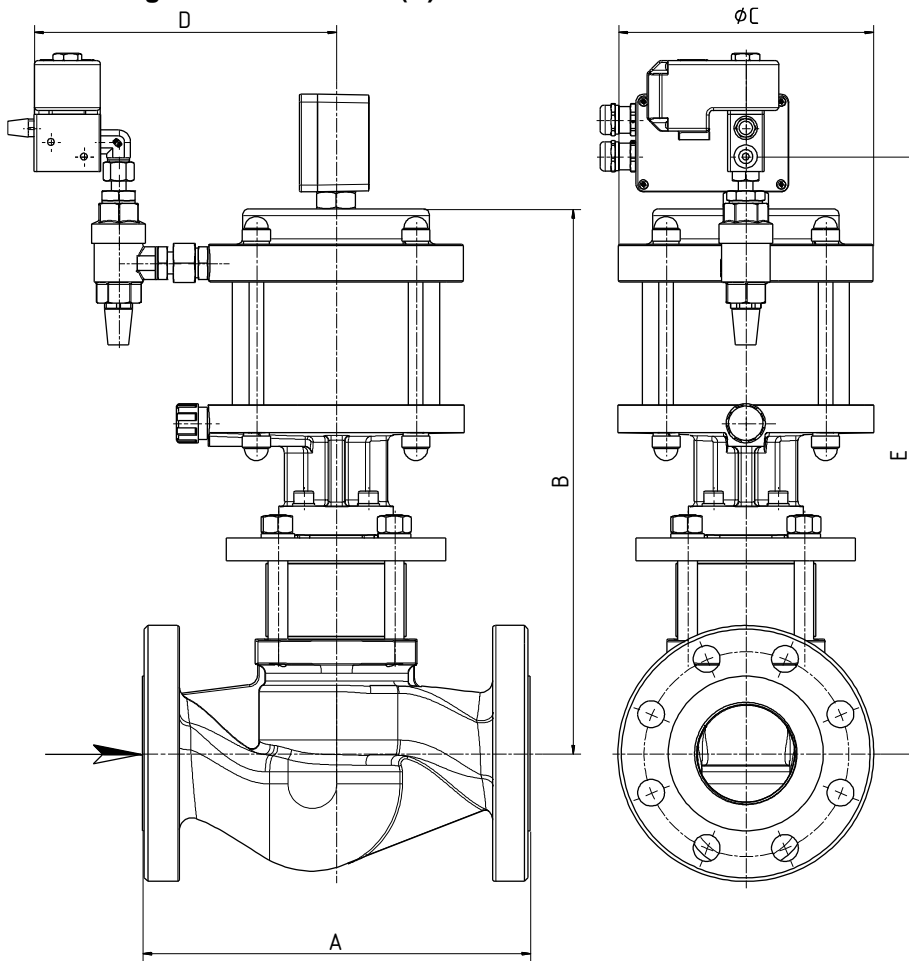
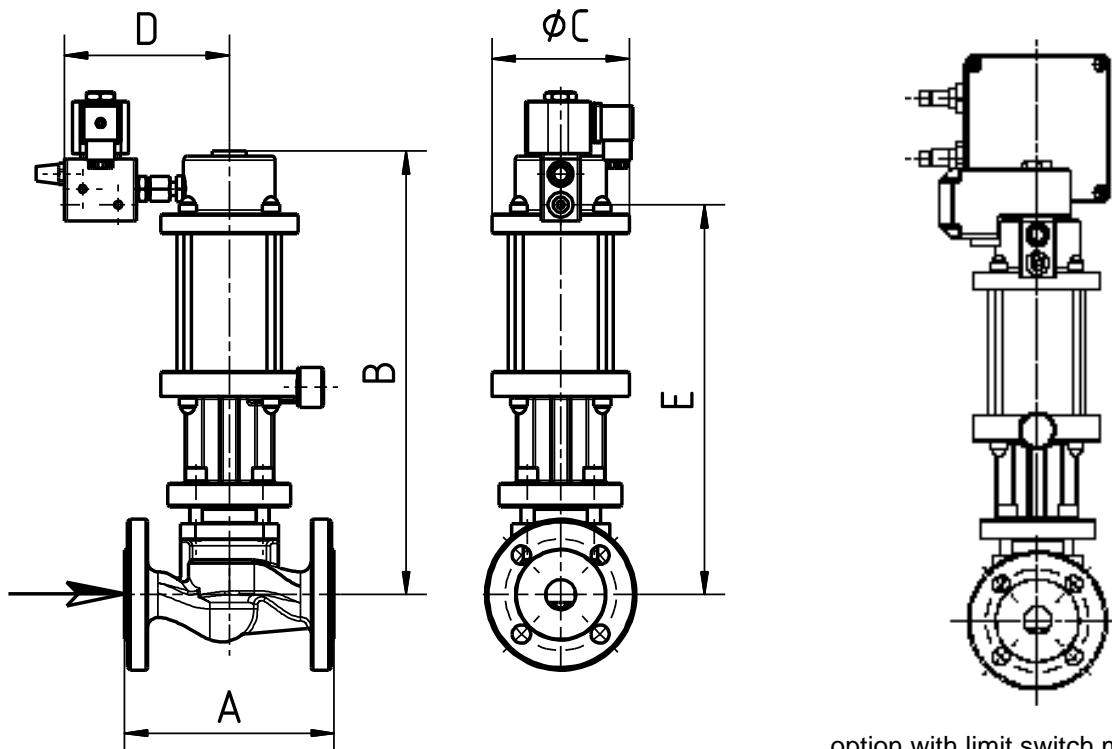
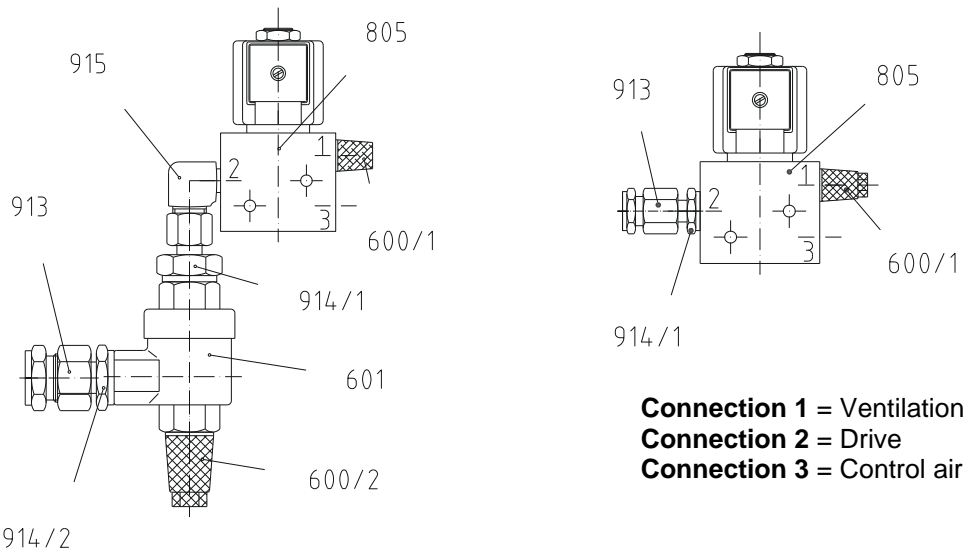

Fig.2 10-4-EPV 10N-4R... ; 10-4-EPV 5/7N.R...



option with limit switch mounting

11.3 Control valve



11.4 List of parts

Pos./ Item	Stück/ Qty.	Benennung	Description
097	1	Endschalteranbau	Limit switch mounting
100	1	Ventilgehäuse	Valve chamber/ housing
108	1	Gehäuseflansch	Housing flange
110	1	Distanzstück	Spacer
111	1	Pneumatikzylinder	Pneumatic cylinder
112	1	Federdom	Spring cap
200	1	Ventilteller	Valve disk
201	1	Tellerscheibe	Disk plate
204	1	Federführung	Spring guide
205	1	Ventilspindel	Valve spindle
206	2	Führungsring	Guide ring
208	1	Schlagdämpfung	Sound insulation
212/1	1	Spindelführung	Spindle guide
212/2	1	Spindelführung	Spindle guide
216	1	Federteller	Spring disk
217	1	Antriebskolben	Drive piston
218	1	Zweiteiliger Ring	Two-piece ring
219	1	Spindelmutter	Spindle nut
220	1	Ausgleichskolben	Balance piston
221	1	Kolbenführung	Piston guide
226	1	Dichtstück	Sealing piece
236/1	4	Stiftschraube	Stud
236/2	4	Stiftschraube	Stud
243	1	Endschalterspindel	Limit switch spindle
246	1	Verbindungsstück Endschalter	Connection piece limit switch
400	1	Ventiltellerdichtung	Valve disc sealing
402	1	Flachdichtung	Flat gasket
403/1	1 (1*)	O-Ring	O-ring
403/2	1 (2*)	O-Ring	O-ring
403/3	2 (1*)	O-Ring	O-ring
403/4	2 (1*)	O-Ring	O-ring
403/5	1 (1*)	O-Ring	O-ring
403/6	1 (1*)	O-Ring	O-ring
403/7	1 (1*)	O-Ring	O-ring
404	2	Lippenring	Lip-ring

Pos./ Item	Stück/ Qty.	Benennung	Description
404/1	2*	Lippenring	Lip-ring
404/2	2*	Lippenring	Lip-ring
404/3	2*	Lippenring	Lip-ring
405	1	Abstreifring	Scraper ring
503	1	Druckfeder	Pressure spring
505	8	Schutzkappe	Protective cap
509	1	Distanzring	distance ring
600/1	1	Schalldämpfer	Sound absorber
600/2	1	Schalldämpfer	Sound absorber
601	1	Schnellentlüfter	Quick-venting mechanism
805	1	Steuerventil	Control valve
901/1	1	Sechskantmutter	Hex. nut
901/2	8 (4*)	Sechskantmutter	Hex. nut
901/3	1 (8*)	Sechskantmutter	Hex. nut
904	1	Verschlussschraube	screwed plug
905/1	4	Federring	Lock washer
905/2	4	Federring	Lock washer
905/3	8	Federring	Lock washer
905/4	1	Federring	Lock washer
910	4	Zylinderschraube	Cylinder screw
913	1	Gerade Einschraubverschraubung	Linear threaded screw connection
914/1	1	Gerader Aufsteckstutzen	Linear put on adapter
914/2	1	Gerader Aufsteckstutzen	Linear put on adapter
915	1	Winkel-Einschraubverschraubung	Angle threaded screw connection
941	1	Gewindestift	Setscrew
943/1	1	Spannstift	Spring dowel sleeve
943/2	1	Spannstift	Spring dowel sleeve
983	1	Entlüftungsstopfen	Exhaust plug

(*) only by 16/40-4-EPV 30N.R...

Spare parts

Version	Fig.	Type	Spare part
Flange version	Fig. 1	16/40-4-EPV...(N).R...	Spare part kit 1
	Fig. 2	10-4-EPVO 10N-4R.. 10-4-EPV 5/7N.R..	Spare part kit 2

Dimension Flange design

Series	DN	A ¹⁾	ANSI	A ²⁾ A ¹⁾	B	ØC	D	E
10-4-EPVO...N-4R..	25	160	1"	203	338	105	126	297
10-4-EPV...N.R...	15	130	1/2"	152	336	105	126	295
	20	150	3/4"	178	336	105	126	295
16/40-4-EPV...N.R...	40	200	1 1/2"	229	430	170	228	473
	50	230	2"	267	450	210	248	483
	65	290	2 1/2"	292	450	210	248	483
	80	310	3"	318	450	210	248	490
	100	350	4"	356	575	265	276	618

A¹⁾ = Dimension at DIN (resp. flanges ANSI and dimension DIN or flanges and dimension at DIN)

A²⁾ = Dimension at ANSI 300lbs (resp. flanges and dimension at ANSI)

A^{*)} = Dimension at ANSI 150lbs (see data sheet on our website armature installation length
225 100 026)